

Ideal for the IoT Era Web Data Logger for On-site Installation

DL30-G

Logging



Web Server



Communication Control



Report Data

Equipment No.	Equipment Name	Equipment Type	Equipment Model	Equipment Location	Equipment Status	Equipment Power	Equipment Temperature	Equipment Humidity	Equipment Vibration	Equipment Noise	Equipment Pressure	Equipment Flow	Equipment Level	Equipment Weight	Equipment Length	Equipment Width	Equipment Height
1	B175.0	550	21000	487.00	01.00	01.00	75.0	48519									
2	B175.0	550	21000	487.00	01.00	01.00	75.0	48519									
3	B175.0	550	21000	487.00	01.00	01.00	75.0	48519									
4	B175.0	550	21000	487.00	01.00	01.00	75.0	48519									
5	B175.0	550	21000	487.00	01.00	01.00	75.0	48519									
6	B175.0	550	21000	487.00	01.00	01.00	75.0	48519									
7	B175.0	550	21000	487.00	01.00	01.00	75.0	48519									
8	B175.0	550	21000	487.00	01.00	01.00	75.0	48519									
9	B175.0	550	21000	487.00	01.00	01.00	75.0	48519									
10	B175.0	550	21000	487.00	01.00	01.00	75.0	48519									
11	B175.0	550	21000	487.00	01.00	01.00	75.0	48519									
12	B175.0	550	21000	487.00	01.00	01.00	75.0	48519									
Sum	B175.0	550	21000	487.00	01.00	01.00	75.0	48519									
Average	B175.0	550	21000	487.00	01.00	01.00	75.0	48519									
Maximum	B175.0	550	21000	487.00	01.00	01.00	75.0	48519									
Minimum	B175.0	550	21000	487.00	01.00	01.00	75.0	48519									

Event Reporting Email

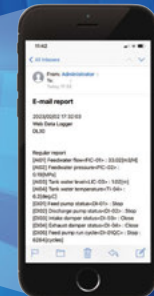

Web Data Logger
Model: DL30-G CE

Features of the DL30-G, a Web Data Logger for the IoT Era

The DL30-G collects and logs (records) data on-site. It also edits and accumulates it in record format (daily, monthly, and yearly report forms) and generates various web screens based on the accumulated data.

These web screens can be monitored on a PC or tablet over LAN or the Internet. On the monitoring side, the PC or tablet only needs a browser with no restrictions on the PC, tablet model, or OS. Furthermore, the DL30-G is also equipped with a function that automatically reports events by email. Such events include alarms that occur on-site, including those for the starting and stopping of equipment. The DL30-G has various built-in communication protocols that support these functions. The DL30-G can be used for various applications, such as data collection and transfer of logging and report data files, by communicating with programmable logic controllers (PLCs) and remote I/O devices.

- The above screen is an inset composite.
- The photo is an image only.
- The contents of the catalog are subject to change without notice.
- We do not deal with mobile communication services for smartphones or tablets.

Conceptual Diagram of DL30-G System Configuration

The DL30-G performs everything from monitoring and recording to report creation on-site, and it is useful as a data logger for the IoT era.

Operating Environment of DL30-G (Configuration with Peripheral Devices)

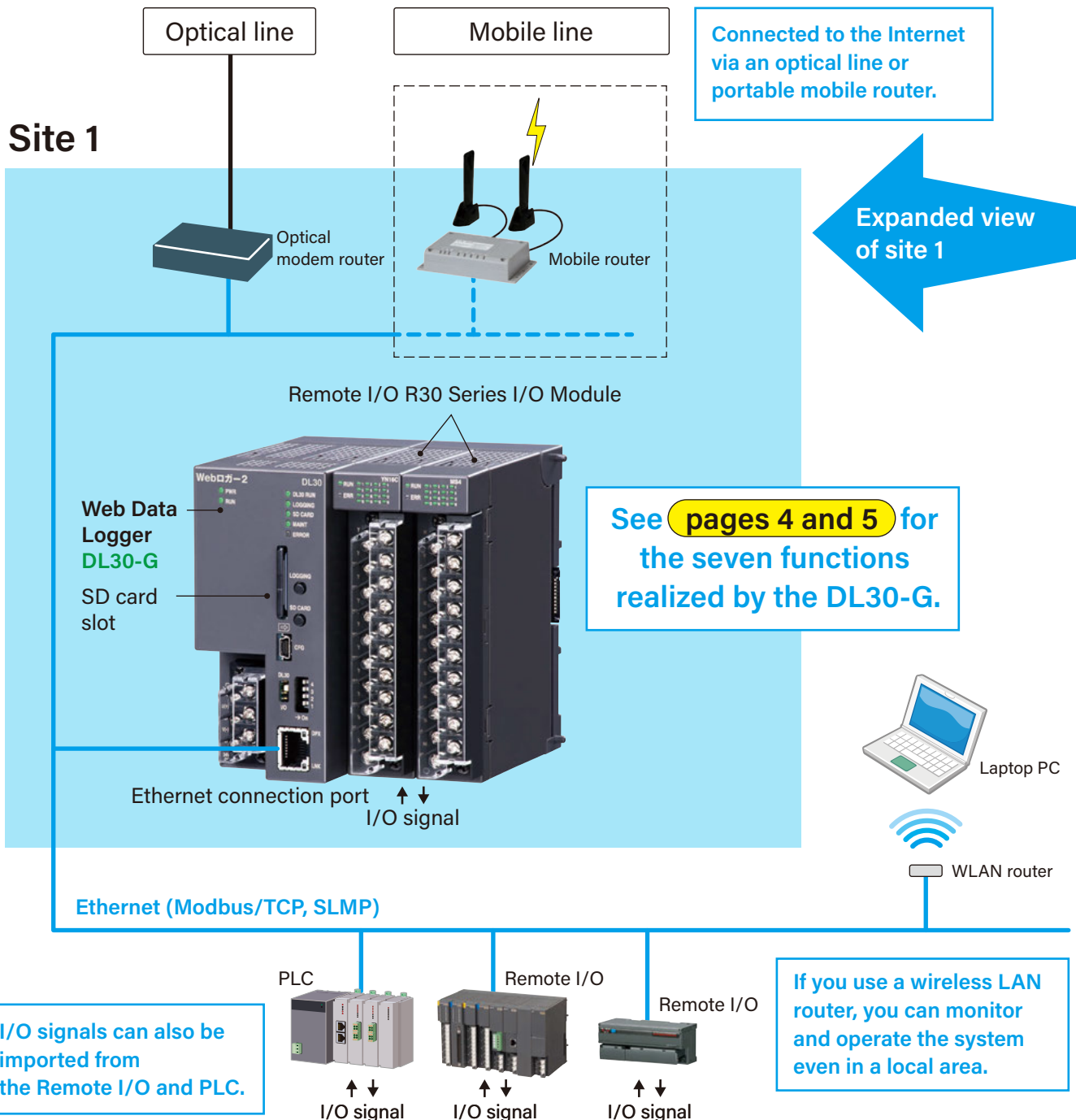

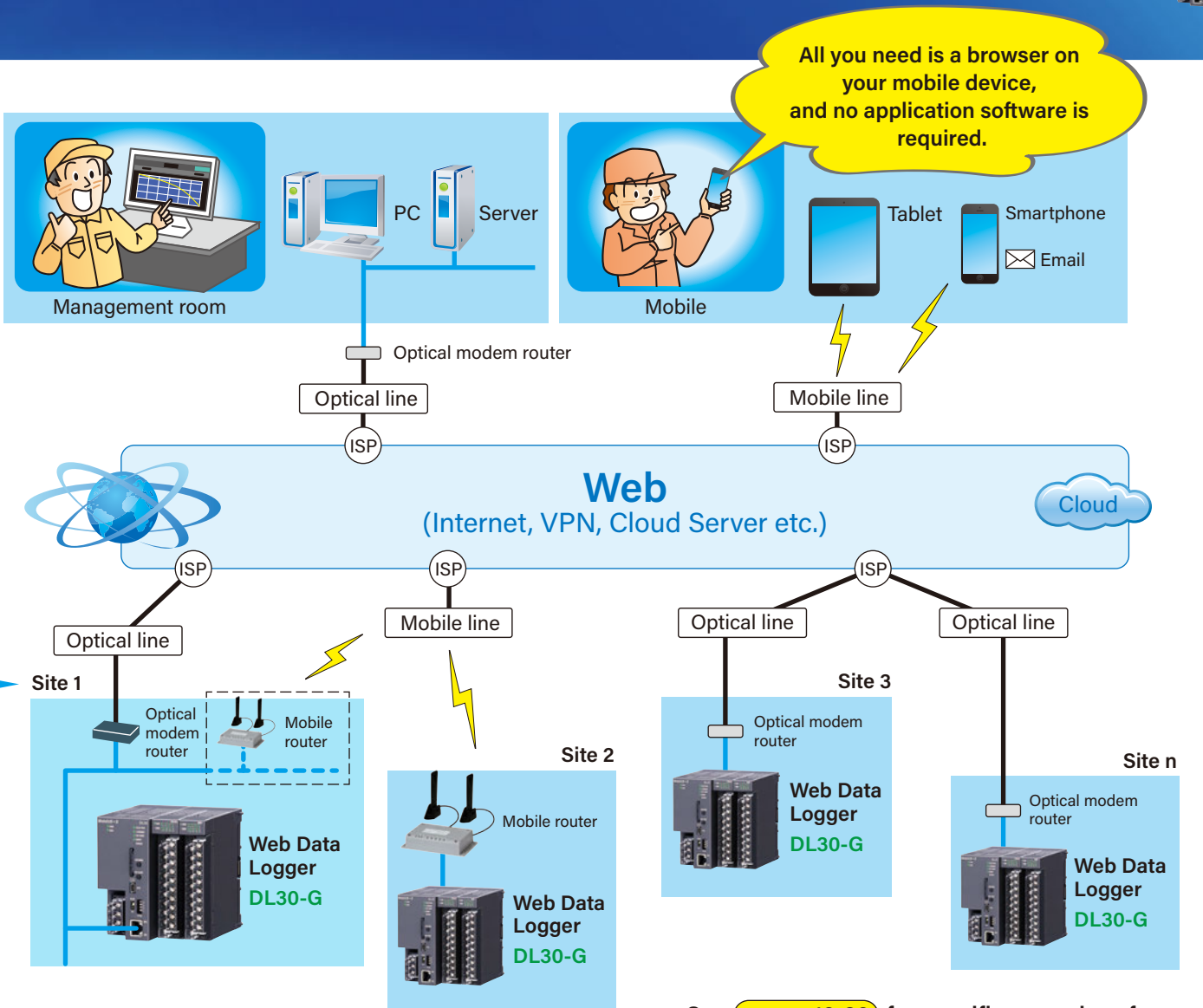

See **pages 16-20** for specific examples of system configurations.

Application Examples

In addition to these examples, the DL30-G can be used for various purposes.

Remote and centralized management of water and sewage facilities

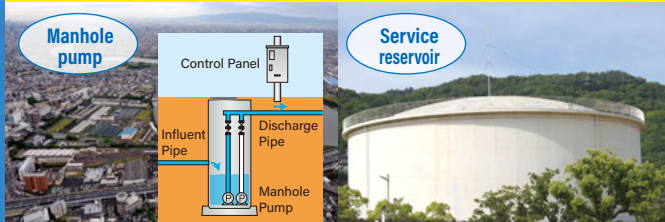

Factory equipment diagnosis, prediction, and preventive maintenance



Remote monitoring of renewable energy facilities



Energy-saving management and billing system for buildings

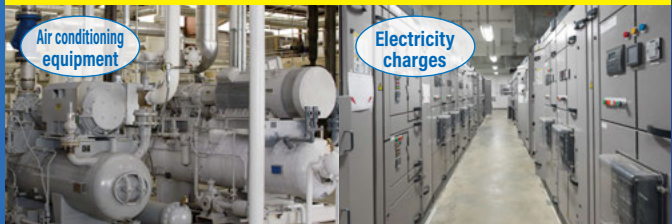

The DL30-G has all of the seven useful functions specified below.

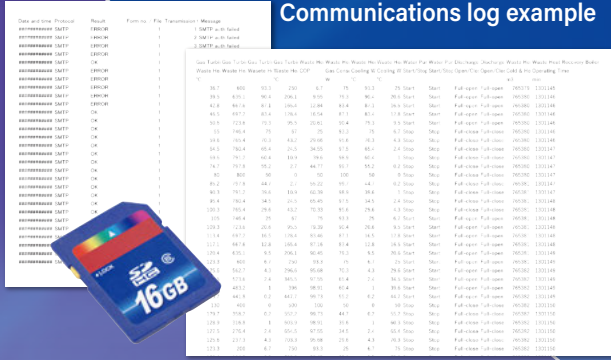

Communications log example

Datalog example

Incorporates sufficient logging functions.

On-site measurement values and event data items are recorded in a large-capacity memory system and transferred to an SD card for recording.

- Records data for more than ten years without maintenance.
- On-site data can be recorded after various types of arithmetic processing.
- Recorded data can be uploaded in CSV format.

This is an on-site web server that can be accessed from any terminal with a browser.

The DL30-G generates various web browser screens where you can monitor the state of the site in real time from a PC or smartphone.

- No application software is required on the terminal side (PC or smartphone etc.) as long as it has a browser.
- Provided with various web browser screens as standard features, including trend, data, event, report, download, and schedule screens.
- Possible to create user-defined screens.
- Remote control is also possible, not just monitoring.

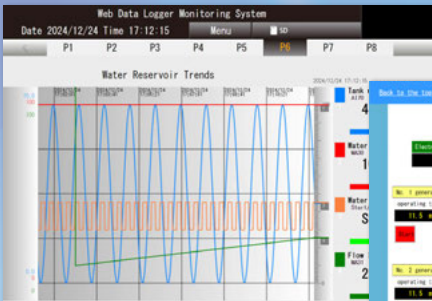

Trend screen

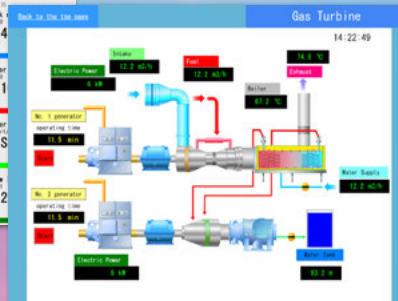

User-defined screen

The screen is an image only.

The DL30-G incorporates a reinforced schedule function, thus automatically turning building air conditioning equipment and lighting equipment on and off as scheduled.

The schedule function starts and stops equipment and devices according to a schedule registered in advance. For example, the pre-cooling operation of the system is performed before the start of work, and forced stops are automatically performed during breaks. You can schedule and register a weekly start/stop pattern, and easily change the pattern for holidays.

Date	INT	no.	Ch name	Ch comment	Start at	End at	Display comment	Color
2024/12/23 (Mon)	Standard	1	Water Well Pump #1	Operation	6:00	16:00	Start	Green
		2	Water Well Pump #2	Operation	9:00	17:00	Full-oper	Red
		3	Gas Turbine for Power Generator	Scheduled Operation	7:30	19:30	Start	Green
		4	Outdoor Lighting Facilities	Scheduled Lighting	18:00	24:00	OFF	Red
		5	Parking Lot Lighting	Scheduled Lighting	0:00	7:00	OFF	Red
		6	Parking Lot Lighting	Scheduled Lighting	18:00	24:00	OFF	Red
2024/12/24 (Tue)	Standard	1	Water Well Pump #1	Operation	6:00	16:00	Start	Green
		2	Water Well Pump #2	Operation	9:00	17:00	Full-oper	Red
		3	Gas Turbine for Power Generator	Scheduled Operation	7:30	19:30	Start	Green

Logging

See pages 6 and 7 for details.

Remote monitoring web server

See pages 8 and 11 for details.

Scheduling

See pages 6-7 and 10-11 for details.

Communications control

See pages 14 and 15 for details.

The DL30-G is equipped with enhanced communication control functions to work as an on-site command tower.

The DL30-G is equipped with a full range of communication control functions for communication with cloud servers, PCs on the Internet, remote I/O, and network communication with PLCs.





The DL30-G incorporates a convenient report creation function.

Daily/Monthly/Yearly reports are automatically created from the recorded data.

No report-creating software for external PCs is required.

- Created report can be uploaded in CSV format.
- You can attach files to emails or monitor them from a web screen.

Daily report

Monthly report

Yearly report

Report creation

See pages 6-7 and 10-11 for details.

The DL30-G is an on-site security guard that makes email reports.

It automatically notifies you by email if on-site data becomes an abnormal value or if an on-site device starts or stops.

- You can set a maximum of 64 report destinations, and you can make address and report content changes using remote settings.
- It has a built-in reporting calendar, and you can stop emails on holidays.
- You can attach report files to emails.

Mail reporting

See pages 12 and 13 for details.

Report calendar example

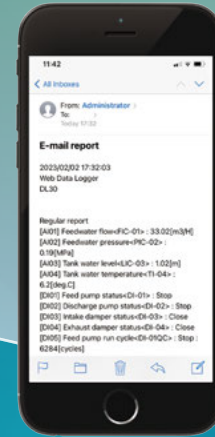

Process operation monitoring

See pages 6-7 and 11 for details.

Incorporating an operation monitoring function.

You can monitor the equipment from your PC or smartphone on the Andon screen and Gantt chart screen, where you can see the operating status of the equipment at a glance.

[Andon screen]

- The Andon screen shows the status of equipment and production lines in real time.
- The arithmetic function performs time display and completes analysis operations.
- The screen displays up to five status levels of both digital data and analog data.

[Gantt chart screen]

- The state of the device and the numerical value (range) are visually expressed with the time axis displayed in the Andon's color.

Gantt chart screen

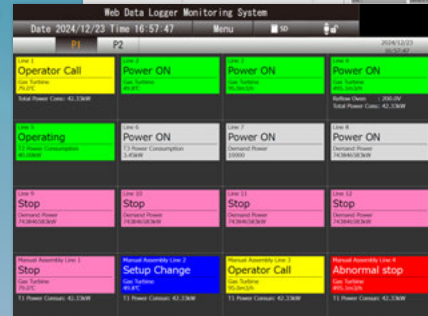
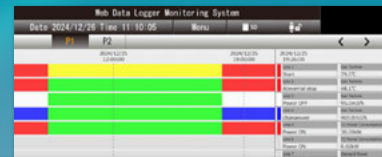

Andon screen

The screen is an image only.



DL30-G

Ethernet
SLMP communication
Modbus/TCP



- FTP server/client function
- HTTPS and FTPS communications supported
- Modbus/TCP master/slave function
- I/O mapping function
- SLMP communication function (CC-Link Partner Association's SLMP-standard compliant)
- SNTP communication function (automatic time adjustments)

The outline of the full logging and form creation functions of the DL30-G

Logging data

The DL30-G samples logging data and report data independently, thus making it possible to set the data individually.

Sampling method: Select from momentary, average, and peak values (maxi/min values)

Max. number of points: 128 (channels)

Basic sampling cycle: 1 second

Sampling cycle (logging): Seconds (1 to 30 seconds), minutes (1 to 30 minutes), time (0:00 to 23:00 with offsetting possible)

Sampling cycle (report): 1 hour

Report

The DL30-G creates daily, monthly, and yearly reports, and edits and saves the Ai, Pi, and MA data of 128 channels in record format.

Daily report: Hourly data is aggregated into 24-hour data.

Monthly report: Daily report data is aggregated into one-month data.

Yearly report: Monthly report data is aggregated into one-year data.

Max. number of points: 128 (channels)

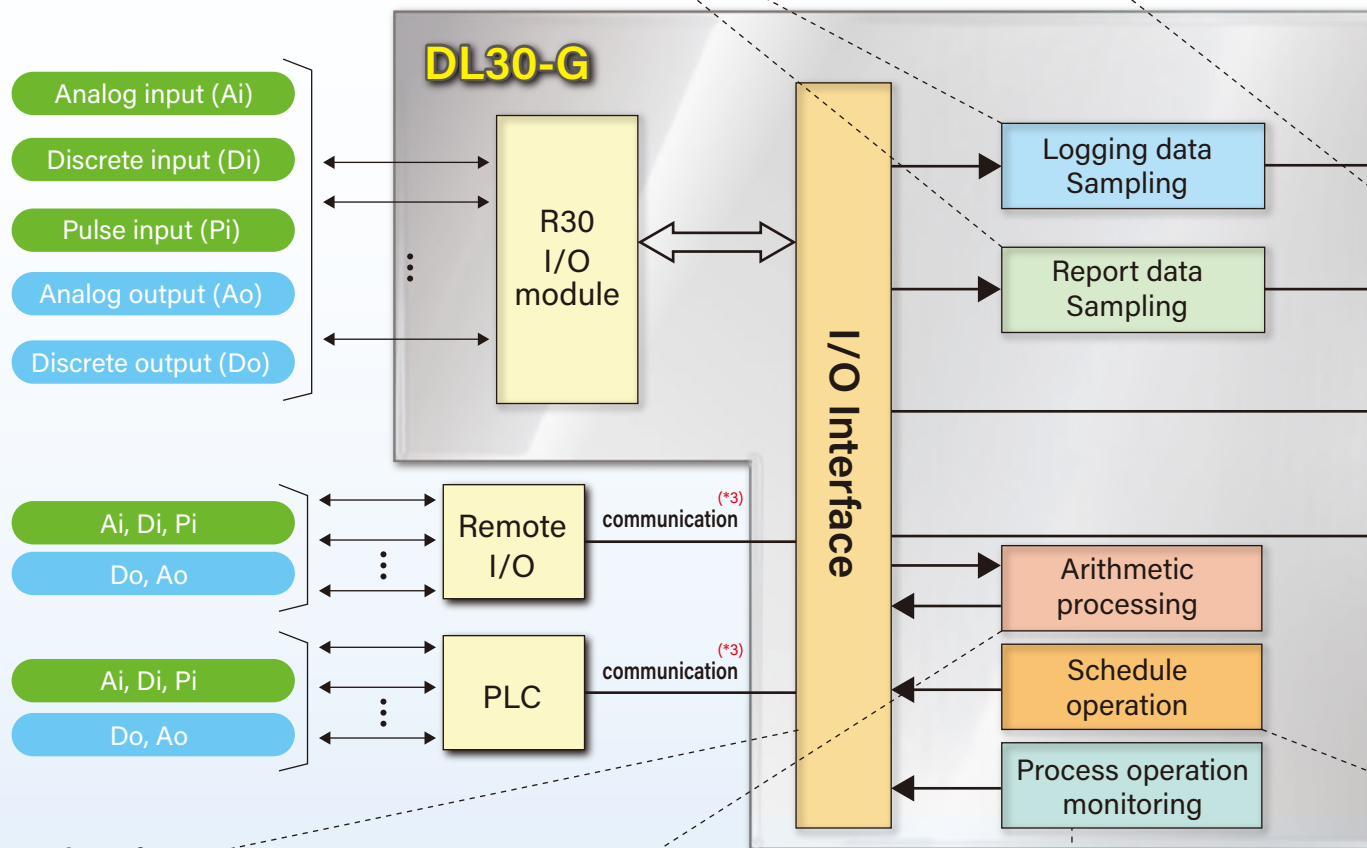

I/O interface

You can import I/O data from R30 Series I/O modules as well as remote I/O and PLC I/O over the communication network.

Analog input (Ai)	: 128 points
Discrete input (Di)	: 256 points
Pulse input (Pi)	: 128 points
Analog output (Ao)	: 64 points
Discrete output (Do)	: 128 points
Analog function register (MA) ^(*4)	: 256 points
Digital function register (MD) ^(*4)	: 256 points

Arithmetic processing^(*4)

The following arithmetic processing can be performed on data that is collected on-site. The values of calculation results can also be sampled as logging and report data.

Types of operations :

Capable of addition and subtraction, multiplication, division, square root, moving average, delay buffer, exp, common logarithm, natural logarithm, peak hold (max/min), power, analog accumulation, F value calculation, scaling, upper/lower signal limiter and logical operation (=, AND, OR, XOR, NOT, RUN).

Process operation monitoring

Andon screen

The conditions of equipment, such as the operation, stop, work shortage, setup change, abnormal stop status, and physical quantities, including the temperature, flow rate, and liquid level, are inputted via remote I/O and displayed together with each item name and numerical value color-coded.

(*1) FTPS supported. (*2) HTTPS supported. (*3) For communications, see page 14. (*4) Math-analog (MA) values (analog calculated values) can be sampled as logging or report format data. Math-digital (MD) values (digital calculated values) can also be sampled as logging data.



is shown in the block diagram.

Internal memory

The DL30-G records logging, event, report, and trend data in binary format in the internal memory.

Logging data capacity: Second- and minute-interval data for 1 day or hourly interval data for 1 month

Report data capacity: 32 daily reports, 16 monthly reports, and 4 yearly reports

Event data capacity: Data on 8,000 events, 8,000 system log entries, and 8,000 communications log entries

Trend data capacity: See page 8

SD card

The DL30-G records the data in the internal memory in CSV format on SD cards.

Estimated recording time (if the SD card capacity is 16 GB):
Logging, event, and report data for 10 years or more (if the logging data is sampling at 64 channels at 1 minute cycles)

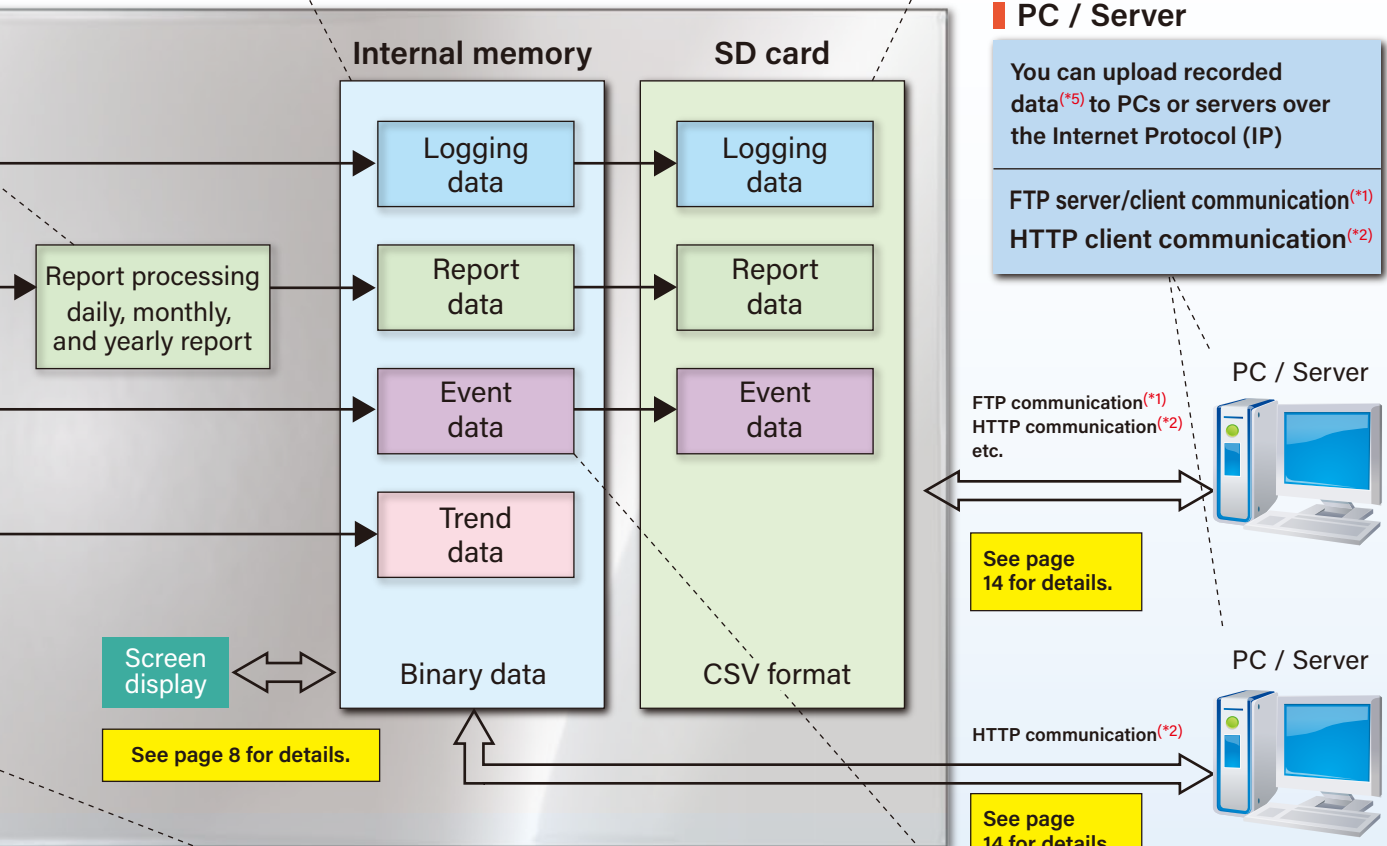

PC / Server

You can upload recorded data^(*5) to PCs or servers over the Internet Protocol (IP)

FTP server/client communication^(*1)
HTTP client communication^(*2)

Gantt chart screen
By displaying the time axis in the Andon's color, both the state and numerical value (range) of each device are visually expressed.

Schedule control

When the start time is reached for a digital output (Do) value or digital function register (MD) value specified according to the registered schedule, the DL30-G will turn the output ON from the corresponding channel and turn the output OFF when the end time is reached. A scheduled pattern is set on a daily basis, and you can assign a pattern for each day of the week.

- Up to 64 schedule patterns can be registered.
- Up to 8 channels can be assigned to a single pattern, and the start time and end time can be set for each channel.
- You can create a schedule for each day of the week, including the current day.

Event

The following 3 types of event data are recorded.

Event log: Information on upper and lower Ai, Pi, and MA limits, Di status, and MD status etc.

System log: Power ON/OFF records, setting changes, and error occurrences etc.

Communication log: Communication records, such as email and FTP records etc.

(*5) Data can be uploaded only over the FTP or FTPS client communications.

A high-performance trend graph display screen is incorporated as a standard function.

Trend screen

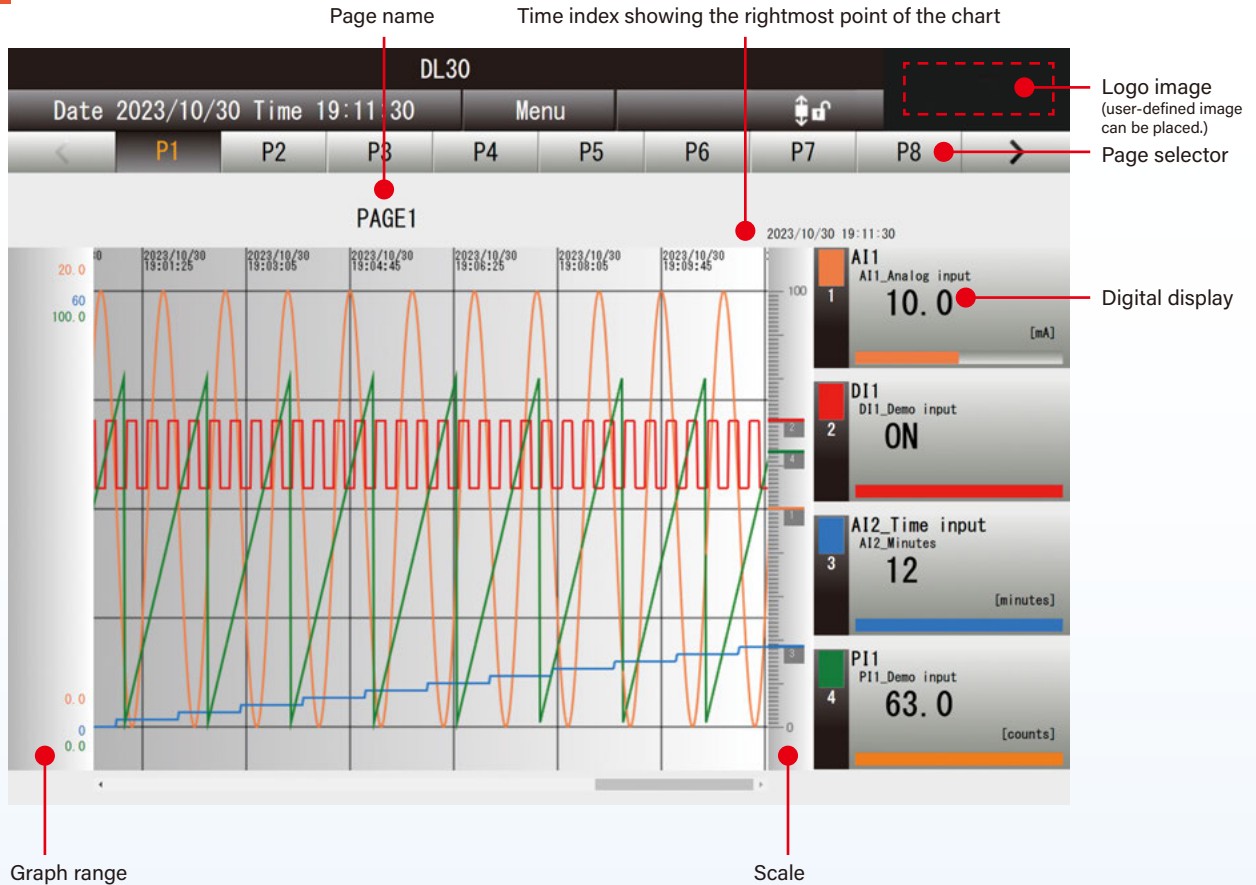

The DL30-G displays **16 trend screen pages** with **4 pens per page (64 pens in total)**. All types of I/O channels (Ai/Di/Pi/MA/MD/Ao/Do/Do groups) are assigned to each pen (duplicate registration is possible). The trend speed can be specified in **1, 5, 10, or 30 seconds, 1, 5, 10, 15, or 30 minutes, 1 hour, or 1 day** in page units. The maximum number of samples is 50,000, and if it exceeds that, it will be overwritten automatically. The display is automatically updated^(*).

Digital display

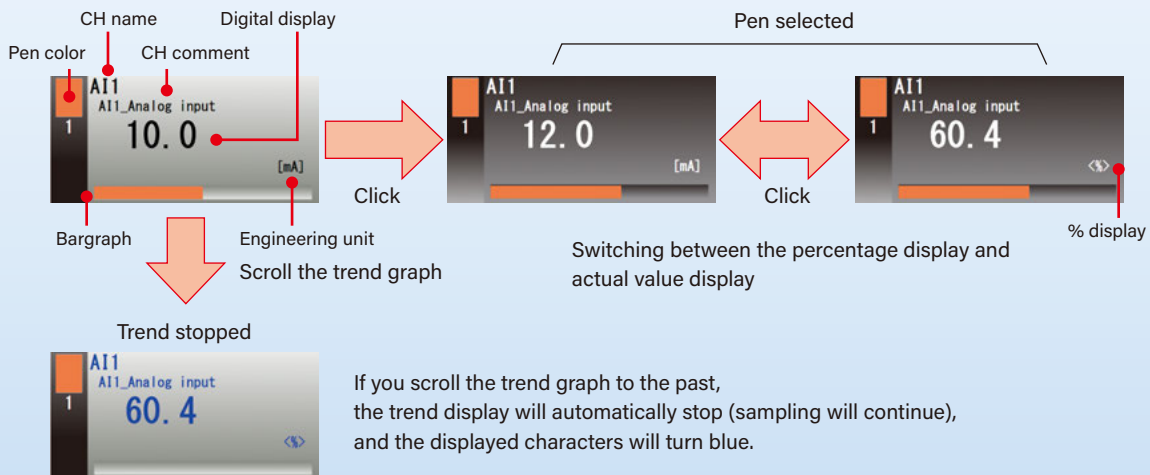

^(*) The display update cycle is 0 to 999 seconds, and if it is set to 0 seconds, the display will not be updated.



Useful features of Trend screen

Changing the maximum and minimum values of the scale

You can change the maximum and minimum values of the scale. You can expand the display range to see the trends, such as when a signal is input on an unexpected scale during measurement.

Showing/Hiding the pen

You can make the trend graph easier to see by leaving only the signals you want to monitor and hiding the others.

Expanding/Shrinking the time axis

You can check the transition of the graph at a glance by shortening the time of the trend graph measured for a long time. The time axis can be switched in four steps: 100% (equal magnification), 50%, 20%, and 10%.

Comparing graphs (moving in the direction of the scale)

You can move the trend graph of the selected pen in the direction of the scale. This is useful when you want to quickly find the difference between 2 graphs that change in the same way.

Comparing graphs (scaling)

You can enlarge the trend graph of the selected pen in the direction of the scale. You can enlarge and observe slight changes in the trend graph.

Changing the update cycle of the display screen

You can change the display update cycle. The display update cycle can range from 0 to 999 seconds. If you set it to 0 seconds, the screen will not be updated automatically. Make settings according to the signal to be measured.

Showing / Hiding the pen

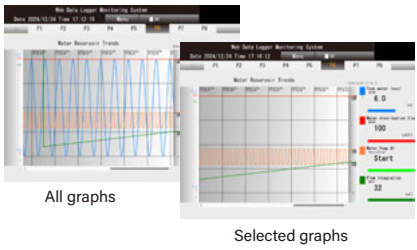

Expanding / Shrinking the time axis

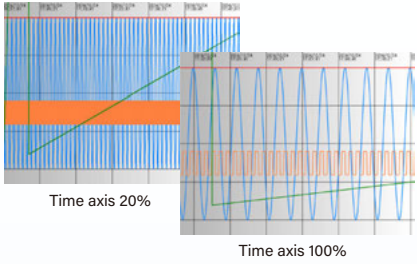

Comparing graphs (moving in the direction of the scale)

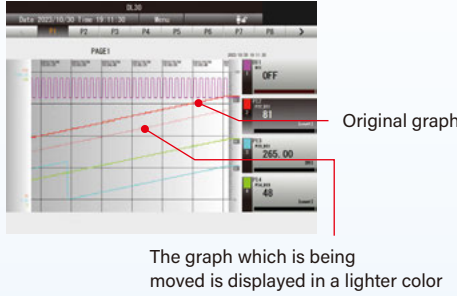

Data screen

The current values of the assigned channels are listed. Displayed items differ depending on the channel type (as in I/O types such as Ai, Di, and Ao). The display is automatically updated(*).

Analog input screen

Web Data Logger Monitoring System							
Date 2024/12/24 Time 17:08:05		Menu		SD			
AI	DI	PI	MA	MD	AO	DO	GDO
CH type	CH name	CH comment	Data	Engineering unit	%	Zone name	Color
Demo (sine wave)	Gas Turbine	Waste Heat Outlet Temperature	25.0	°C		Outlet temperature normal	Green
Demo (sine wave)	Gas Turbine	Waste Heat Return Temperature	904.7	°C	90.47	Boiler temperature abnormally high	Red
Demo (sine wave)	Gas Turbine	Waste Heat	37.4	m3/h	37.46		

Analog output screen

Web Data Logger Monitoring System					
Date 2024/12/24 Time 16:34:49		Menu		SD	
AI	DI	PI	MA	MD	AO
CH type	CH name	CH comment	Data	Engineering unit	Input
I/O module	Boiler target IND	AO01	10.00	%	
I/O module	Valve position IND	AO02	0.00	%	

Event screen

The screen displays up to 2,000 event data items (i.e., event log, system log, communication port data) stored in the internal memory chronologically. You can switch the display of all events, the current day's events, and the previous day's events. The display is automatically updated(*).

Event screen

Web Data Logger Monitoring System							
Date 2024/12/24 Time 16:34:49		Menu		SD			
Evt	Sys	Com	Sch	Filter		Select	
Date	Time	CH No.	CH name	CH comment	Event No.	Message	Color
2024/12/24	09:00:00	MD29	Manual Assembly 2_1	MD28	1	ON	Green
2024/12/24	09:00:00	MD28	Manual Assembly 1_5	MD27	1	Abnormal stop	Red
2024/12/24	09:00:00	MD27	Manual Assembly 1_4	MD27	1	Operator Call	Yellow
2024/12/24	09:00:00	MD26	Manual Assembly 1_3	MD27	1	ON	Blue
2024/12/24	09:00:00	MD6	Water Well Pump #2	Operation	1	Full-open Water Well Pump #2	Red
2024/12/24	07:30:00	MD7	Gas Turbine for Power Generator	Scheduled Operation	1	Start Gas Turbine for Power Generation	Green
2024/12/24	07:00:00	MD9	Parking Lot Lighting	Scheduled	1	Parking Lot Lighting OFF	Red
2024/12/24	00:00:00	MD8	Outdoor Lighting Facilities	Scheduled	1	Outdoor Lighting Facilities OFF	Red
2024/12/23	19:30:00	MD7	Gas Turbine for Power Generator	Scheduled	1	Stop Gas Turbine for Power Generation	Red
2024/12/23	18:00:00	MD9	Parking Lot Lighting	Scheduled	1	Parking Lot Lighting ON	Green
2024/12/23	18:00:00	MD8	Outdoor Lighting	Scheduled	1	Outdoor Lighting	Green

(*) The display update cycle is 0 to 999 seconds, and if it is set to 0 seconds, the display will not be updated.

The created report can be monitored from the browser.

Report screen

The DL30-G displays saved report data (daily, monthly, and yearly) in the internal memory in tabular format. One table displays eight-channel data, and the following tables display ninth-channel data and later.

Daily report example

Browser display screen

Display contents

This is convenient, and you can transfer the report automatically.

You can attach the report to an email and send it automatically.

See page 13 for details.

You can use the email report function to send a report file saved on an SD card by email. You can set the transmission timing of the report to the time of file updating and the transmission timing of logging data and log data to the time of filing.



Automatically sent from the FTP client.

See page 15 for details.

You can use the FTP client environment to send a report file saved on an SD card to the FTP server. The timing of transmission occurs when the file is updated.

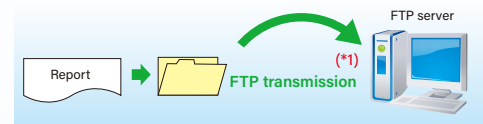

Download screen

A list of logging data, report data, and event data stored in the internal memory or SD card is displayed.

A list of folders and a list of files are displayed on the left-hand side and the right-hand side, respectively. You can download the data in the internal memory and files on the SD card. You can also manually delete old files in the SD card.

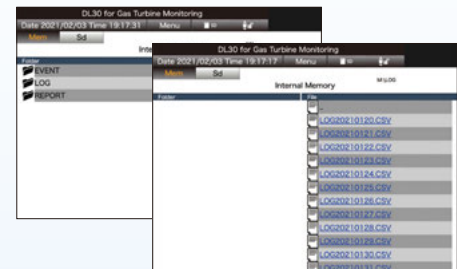

Schedule screen

You can check the current status of channels operating according to the schedule registered in advance. You can specify up to 8 channels of digital output (Do) values and digital function register (MD) value in a single schedule, and set the start time of ON output and the end time of OFF output for each. You can register up to 64 schedule patterns per day. The registered pattern will be allocated from the current day to one week ahead. For example, you can use 7 patterns to set different schedules for each day of the week or use 2 patterns to allocate a weekday schedule from Monday to Friday and holiday schedule on Saturday and Sunday.

Schedule monitoring screen

Schedule setting screen

You can specify 8 Do or MD channels.

Set the start time (ON time) and end time (OFF time) for each channel.

Features of Schedule Function

- You can edit start/end time settings, register devices, and perform various types of maintenance on the web screen.
- Using the group digital output (GDo) channel function^{(*)2}, you can operate digital output (Do) values and digital function register (MD) value collectively.
- With external contact input, you can use the schedule function to turn all outputs OFF at once.
- You can register a special day pattern by specifying the year, month, and day.



Process operation monitoring

Andon^{(*)3} screen

The Andon screen shows the status of equipment and production lines in real time.

This function displays the current status of production equipment with the Andon. The conditions of equipment, such as the operation, stop, workpiece shortage, setup change, or abnormal stop status, and physical quantities, including the temperature, flow rate, and liquid level, are input via remote I/O and displayed together with each item name and numerical value distinguished by color coding.

The arithmetic function performs time display and completes analysis operations.

The DL30-G has a function to integrate the contact ON or OFF time. You can use this to display the accumulated time of various states. Furthermore, the DL30-G has versatile calculation functions, and it is possible to perform time measurement and various types of analysis, including the operating rate analysis of devices using the counter function.



Andon screen

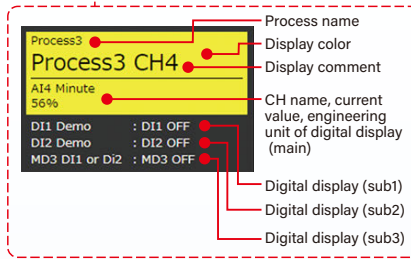

Digital Data Display

The DL30-G can display up to 5 status levels by combining digital inputs or digital function register values. The display contents are display names, display colors, and numerical values (as main items), as well as three numerical values (sub-items 1 to 3).

Analog Data Display

The DL30-G can display 5 status levels of display colors, display comment, and numerical values (as main items) for the corresponding analog inputs, pulse inputs, and analog function register value range, as well as 3 numerical values (sub-items 1 to 3).

Gantt chart screen



Gantt chart screen

In the Gantt chart, the conditions of devices and the numerical value range are visually expressed by displaying the time axis in the Andon's color. The DL30-G displays 12-hour data on a single screen. Furthermore, the DL30-G displays data for up to 48 hours in the past with the screen scrolled.

Display of Digital Data and Time Axis

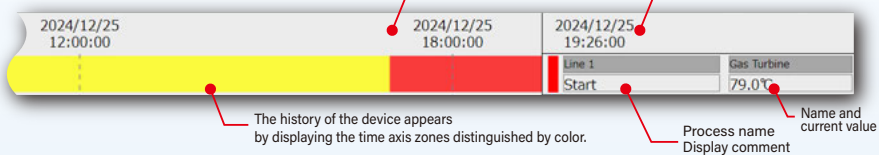

Analog Data and Pulse Data Display

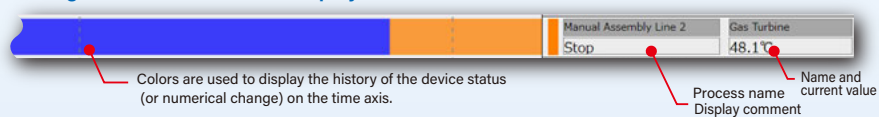

User-defined screen^{(*)4}

You can create web screens freely by making full use of HTML, JavaScript, image data (gif or jpg), CSS, etc. Furthermore, the current value of data measured by the DL30-G can be read as a JavaScript data file. DL30 Web Designer (user-defined screen creation software for the DL30-G) is available as a dedicated tool for easily creating user-defined screens. The created data is transferred from DL30 Web Designer to the DL30-G through a USB cable or over the Ethernet. The maximum capacity is 4 MB.

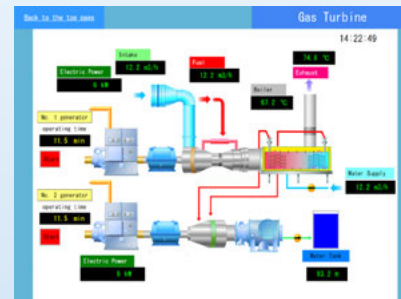

(*)1 FTPS supported.

(*)2 The group digital output (GDo) channel function can handle digital output channels (Do and MD) as a grouped virtual channel.

(*)3 In manufacturing, the term andon (Japanese: originally meaning paper lantern; Japanese manufacturers began its quality-control usage.) refers to a system which notifies managerial, maintenance, and other workers of a quality or processing problem. The alert can be activated manually by a worker using a pullcord or button or may be activated automatically by the production equipment itself. The system may include a means to pause production so the issue can be corrected. Some modern alert systems incorporate audio alarms, text, or other displays; stack lights are among the most commonly used.

(*)4 The DL30 Web Designer is downloadable for free from our website. The screen is an image only.

The DL30-G is an on-site security guard that makes email reports.

With various reports, you can accurately grasp the situation occurring on-site.

Email Notification Mechanism

Four types of email notification are available according to the situation. They are **event notification**, **regular notification**, **report transmission (notification)**, and **test notification**. An event notification reports the situation or abnormality, such as when an operation or failure contact signal is input or when the analog signal exceeds a control value. A regular notification with form transmission reports the current value and form data regularly. A test notification is a report of items to be confirmed by a trial run and maintenance. When the conditions for a notification occur, an email form, including information on the address, subject, and text, will be generated and executed.

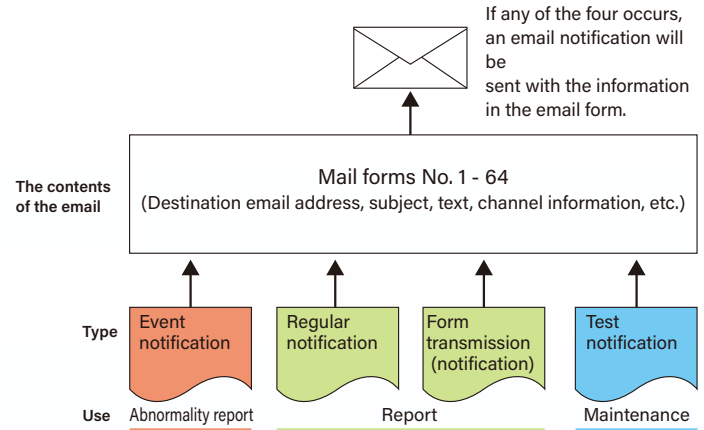

Convenient Setting Function to Allow Remote Email Settings

You can register up to 64 email recipients. Specify the destination for each mail form and send it. If the email notification fails, it will be automatically resent up to 3 times every 30 seconds. If the system still cannot send the email, it can make external contact output to report the error.

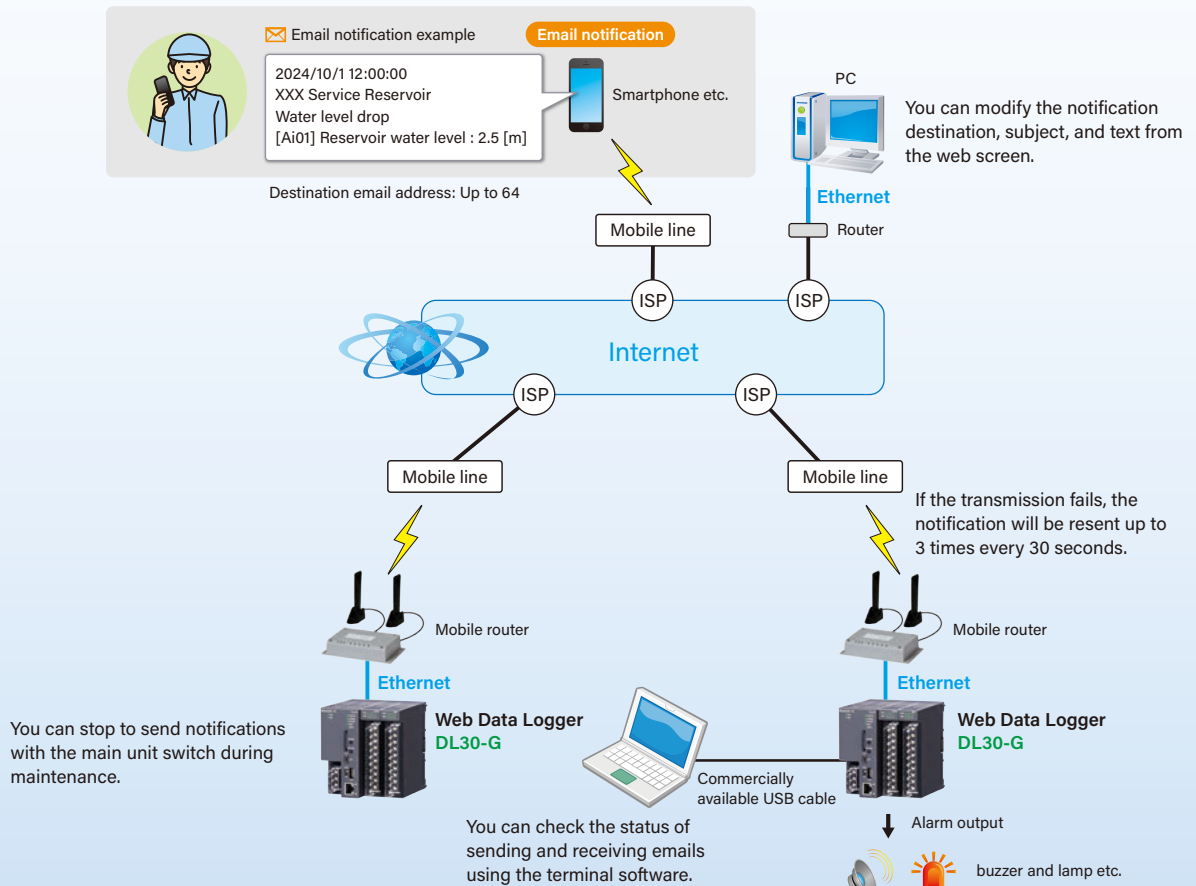

Note: If you want to use email notification, you need a separate email account for the mail server prepared by the provider. To connect to the Internet for monitoring, static IP or dynamic DNS is required. Contact us for the mobile router to be combined.



You can fill out the email form with the name and time of the measurement point with ease and attach forms.

Fill out the email form to layout your email. You can insert the transmission time, as well as the name and comment of each channel (measurement point), in the message. Furthermore, you can include more details, such as the status of I/O contact points, analog current value (the water level and flow rate etc.), integrated value, and internal calculation results in the email. You can report information with specific numerical values (XX m and YY m3/h etc.). You can register up to 128 emails. You can also attach and send daily, monthly, and yearly report data in CSV to the email for ease of managing report data.

Email Form Setting Screen

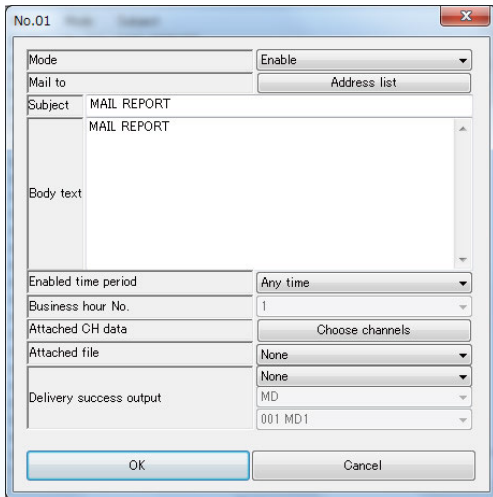

Original html tag

[_TIM_]	The time when a mail transmission is confirmed.
[_NAM_]	CH name (valid only for an event report)
[_COM_]	CH comment (valid only for an event report)
[_MSG_]	Event message (valid only for an event report)

You can share a form by embedding a special tag in the text. In other words, if a text correction occurs, you only need to edit the form.

(Example)

- Dedicated tag Text sent by email
- [_TIM_] → 2024/11/10 12:00:10
- [_NAM_] → No. 1 pump
- [_COM_] → 1st Service Reservoir
- [_MSG_] → A failure has occurred

Calendar of Reports to Distinguish Saturday, Sunday, Holidays, and Working Hours

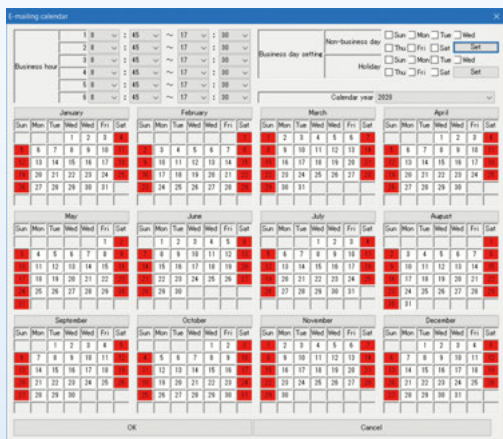

You can select the time zone for sending emails. You can freely specify weekdays, holidays, during working hours, after working hours, etc. by setting the reporting calendar in the email report on the setting screen. For example, you can use it with the person in charge inside the company during working hours and the person in charge of the maintenance company outsourced outside working hours.

Sending Emails at Any Time Using a Clock Variable

Type	Input value
Second	0 - 59
Minute	0 - 59
Hour	0 - 23
Day	1 - 31
Month	1 - 12
Day of week	Sun.: 0, Mon.: 1, Tue.: 2, Wed: 3 ... Sat.: 6

You can register the second, minute, hour, day, month, and day of week on the analog channel (Ai) to send an email at any time. For example, you can send a monthly report, along with a regular report at 1:00 am every Sunday.

Collectively controls PLC, Remote I/O, and the Internet communication.

Overview

The DL30-G incorporates various communication protocols, including protocols for TCP/IP, HTTP server^{(*)1}, FTP server/client^{(*)2}, SMTP client, SNTP client, Modbus/TCP master/slave, and SLMP master communications. It is possible to connect the DL30-G to the Internet through an external router and via a broadband (optical and CATV etc.) or high-speed mobile communication service for remote monitoring and signal transmission.

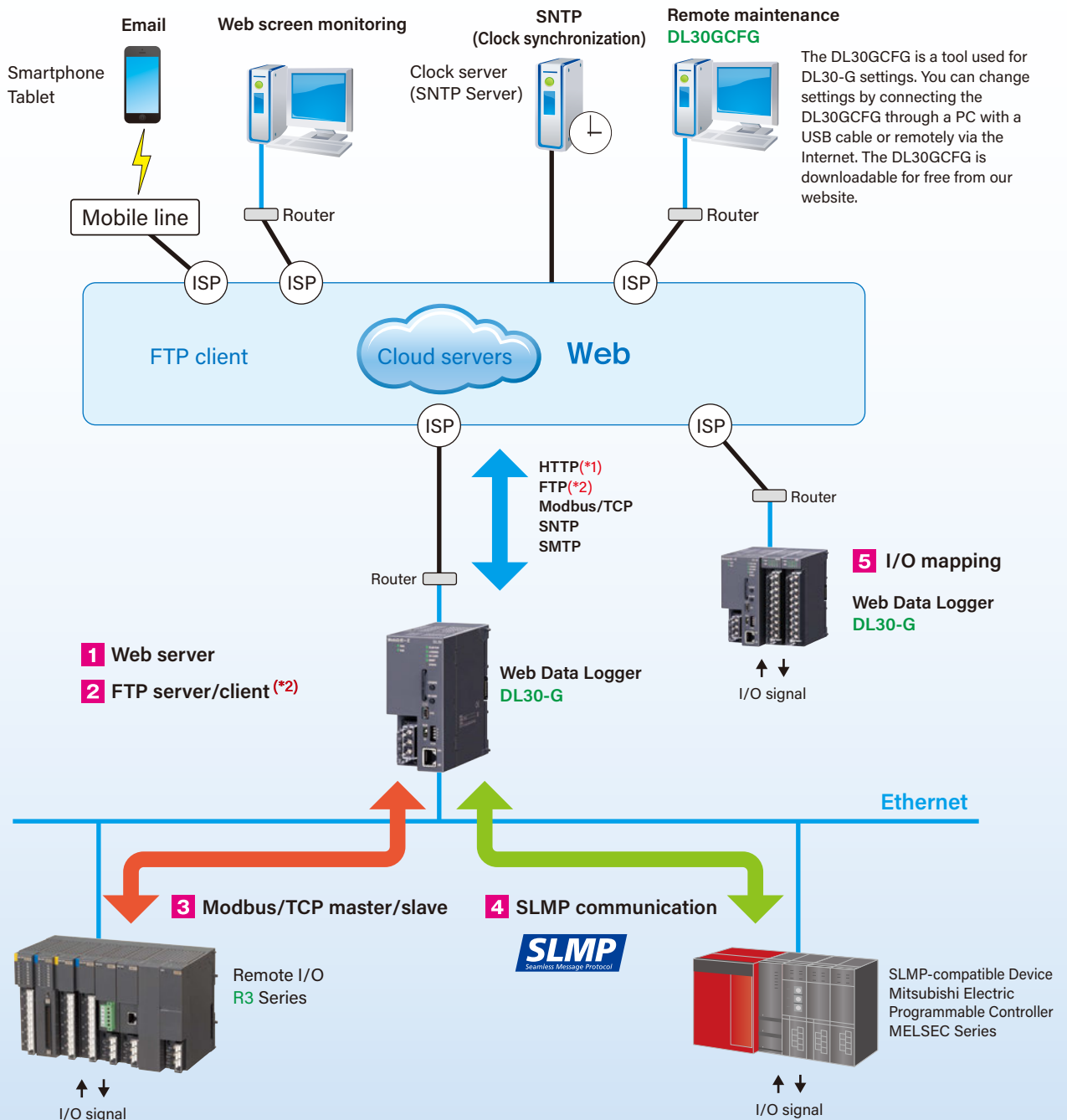

SLMP: Seamless Message Protocol (A common protocol that seamlessly connects CC-Link IE and Ethernet products)



Monitors data collected through the Internet communication.

- 1** Web server
- 3** Modbus/TCP master/slave
- 4** SLMP communication

You can use the SCADA system and centrally monitor Modbus devices and devices compatible with the SLMP.

The DL30-G can be connected to up to 64 remote I/O and SLMP-compatible devices via Modbus/TCP communication and SLMP communication to expand I/O. You can monitor imported data in a trend graph or aggregated report over the web.

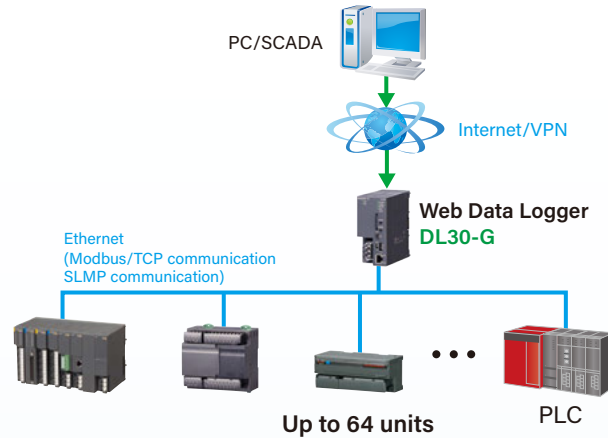

The DL30-G can be expanded by connecting to remote I/O and SLMP-compatible devices.

Created data is automatically transferred over the FTP or acquired manually.

- 2** FTP Server/client(*2)

The DL30-G generates data at a remote site, but the generated data can be freely transferred over the FTP.

You can transfer CSV files recorded and saved on the DL30-G to an FTP server or retrieve files to the DL30-G from an FTP client. To use the FTPS server, install the server certificate created by software (LCA-DL30) supporting certificate authority creation on the DL30-G. LCA-DL30 can be downloaded free of charge from our website.

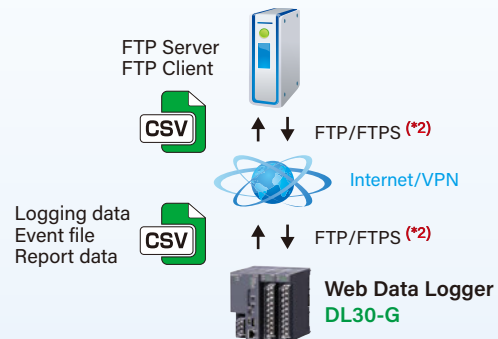

I/O mapping that can be used as a telemeter.

- 5** I/O mapping

You can build a fast and economical IP telemeter system.

Through an IP network, such as LAN/WAN, or a virtual private network (VPN), you can use the communication function of the DL30-G to freely exchange input and output signals between Remote I/Os on the network. You can build an IP telemeter system via the DL30-G to centrally monitor signals from a remote site.

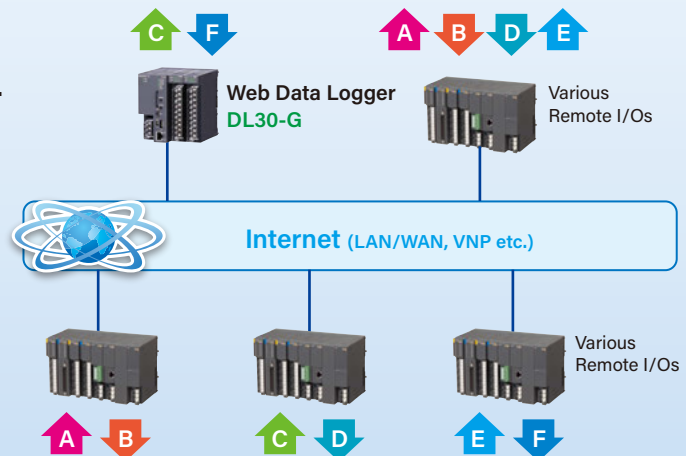

How to View On-site Data

1 Using LAN for on-site monitoring

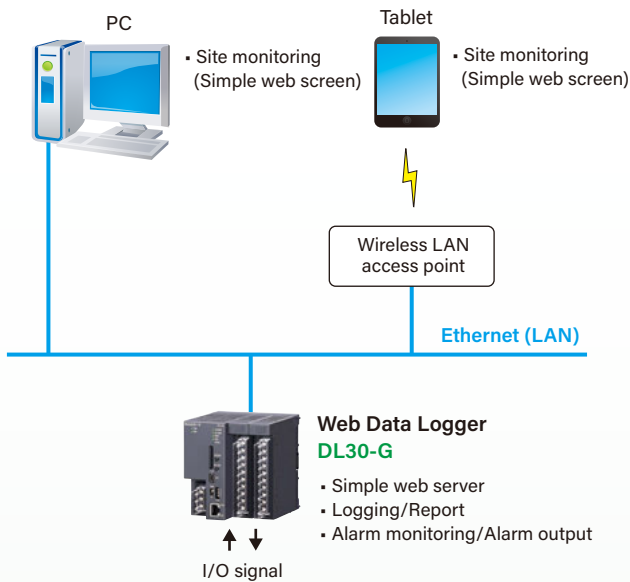

DL30-G screens

Trend screen example

Daily report example

Monthly report example

Yearly report example

Commentary

- Access the on-site DL30-G unit over the LAN from a browser on a PC or tablet.
- You can check the trend graph, event log, and report screen provided standard with the DL30-G.

2 Centralized monitoring of distributed sites throughout the plant over the LAN

User-customizable SCADA monitoring screens

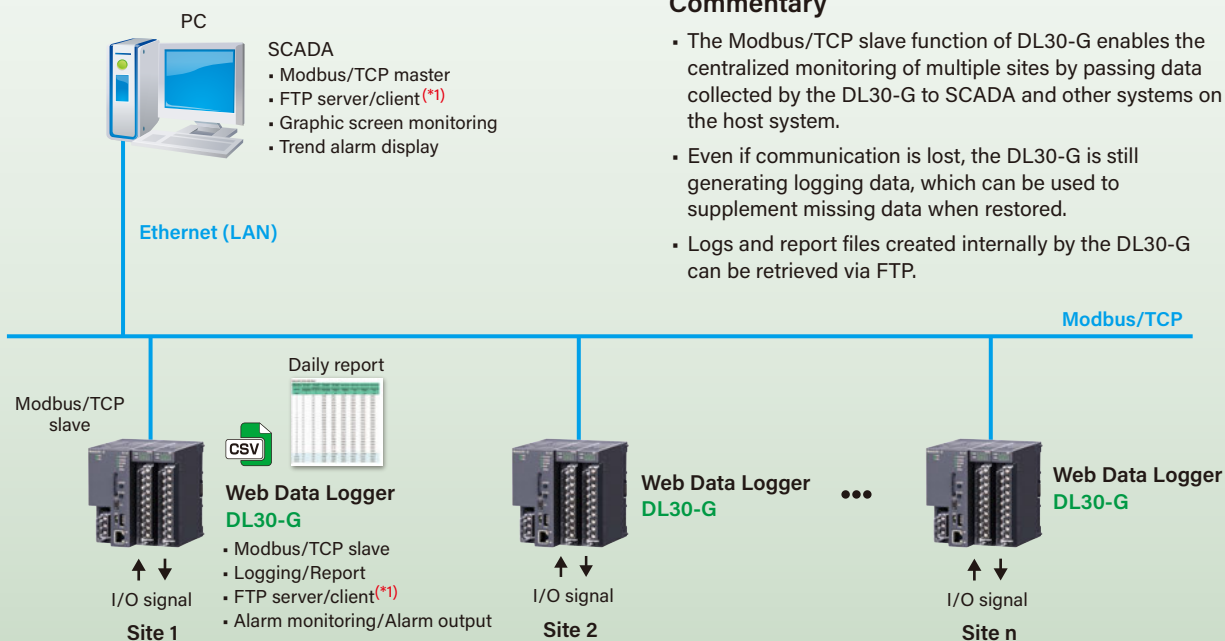

Commentary

- The Modbus/TCP slave function of DL30-G enables the centralized monitoring of multiple sites by passing data collected by the DL30-G to SCADA and other systems on the host system.
- Even if communication is lost, the DL30-G is still generating logging data, which can be used to supplement missing data when restored.
- Logs and report files created internally by the DL30-G can be retrieved via FTP.



3 Remote monitoring and email notification using an Internet connection

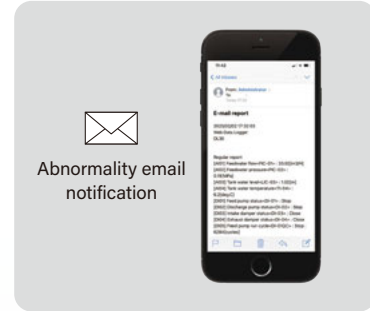
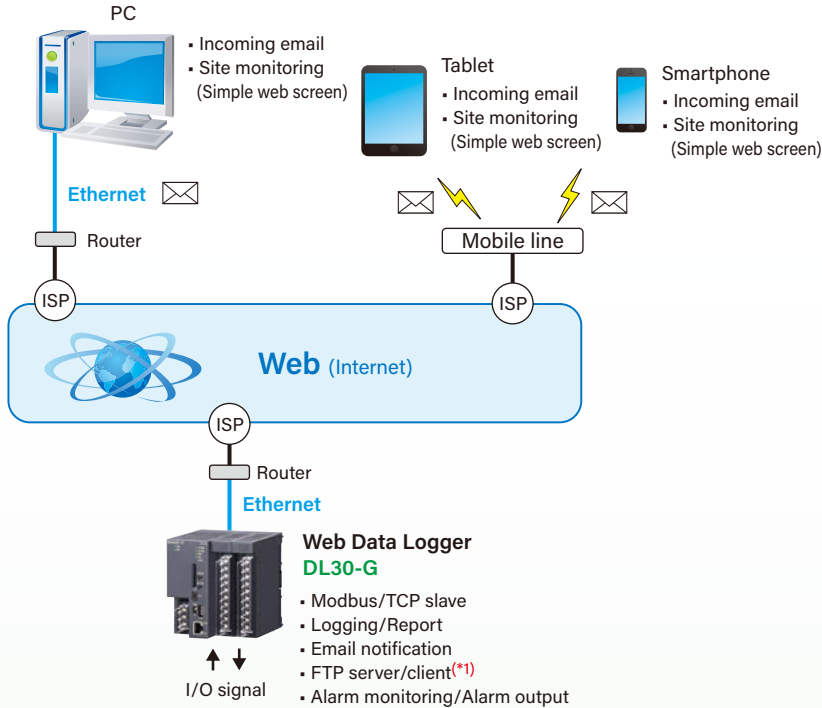

Commentary

- Data collected by the DL30-G installed at a remote site can be monitored via the Internet using a PC or tablet browser.
- Anomalies in remote areas can be detected via email using the Internet.

On-site monitoring requires the registration of a fixed IP address or dynamic DNS service.

4 Centralized monitoring of multiple remote locations using the Internet or mobile lines

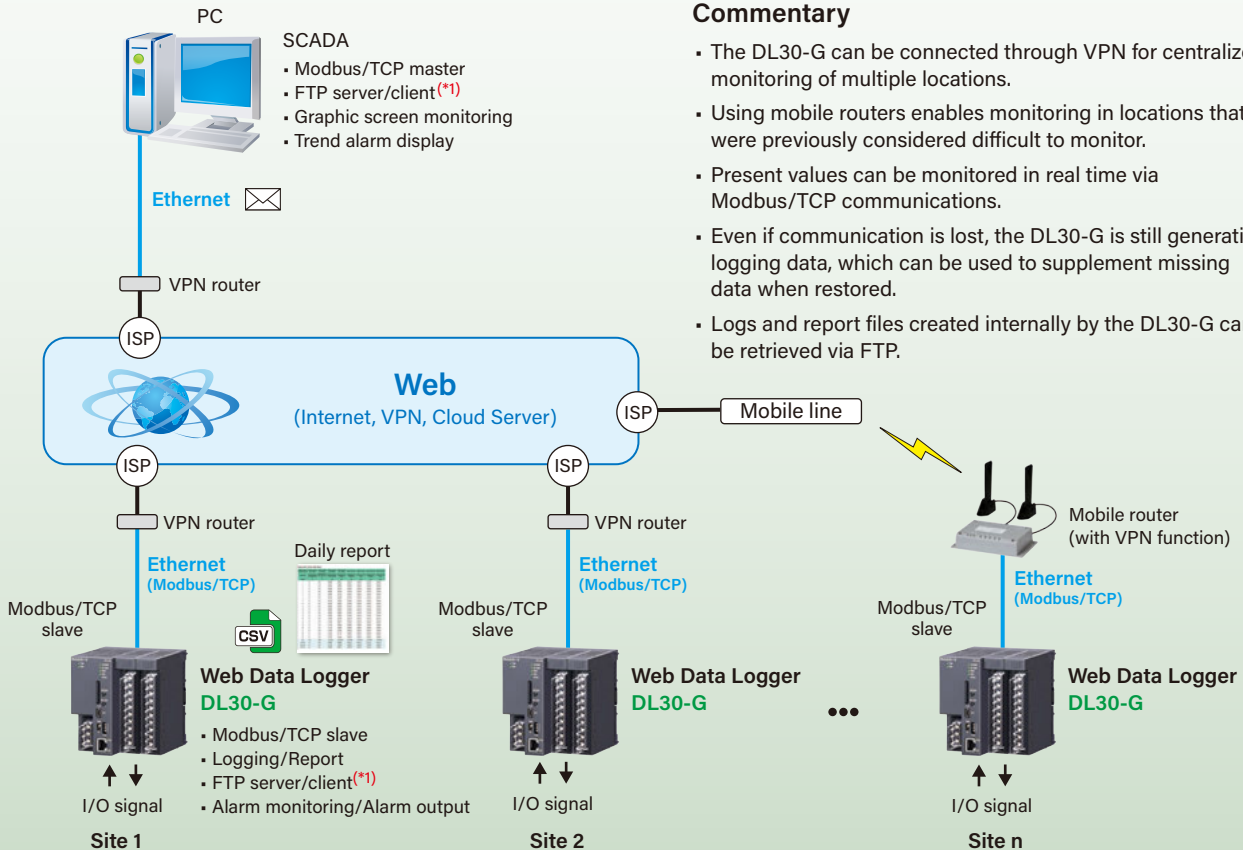

Commentary

- The DL30-G can be connected through VPN for centralized monitoring of multiple locations.
- Using mobile routers enables monitoring in locations that were previously considered difficult to monitor.
- Present values can be monitored in real time via Modbus/TCP communications.
- Even if communication is lost, the DL30-G is still generating logging data, which can be used to supplement missing data when restored.
- Logs and report files created internally by the DL30-G can be retrieved via FTP.

On-site monitoring requires the registration of a fixed IP address or dynamic DNS service.

I/O Signal Retrieval Method

1 Retrieving signals from I/O modules

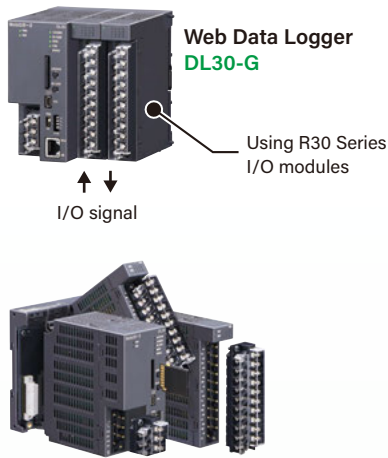

Commentary

- Remote I/O R30 Series I/O modules are installed on the base to retrieve I/O signals.
- A separate base must be provided when mounting I/O modules.
- See the latest specifications for I/O modules that can be mounted.

2 Retrieving remote I/O signals

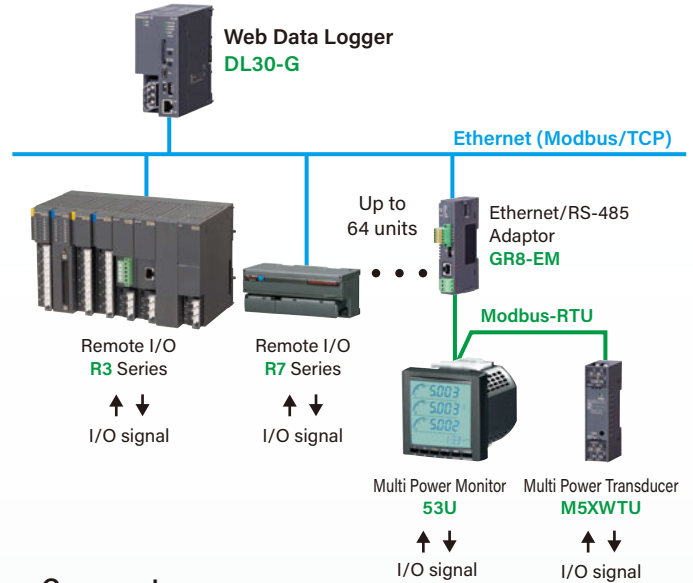

Commentary

- Connects to various Remote I/Os via Modbus/TCP to capture I/O signals.
- I/O signals from remote I/Os connected via Modbus-RTU through the Ethernet/RS-485 Adaptor (model: GR8-EM) can also be retrieved.

3 Retrieving signals from open networks

Commentary

- Use the Ethernet/RS-485 Adaptor (model: GR8-EM) to import data from Modbus-RTU devices.

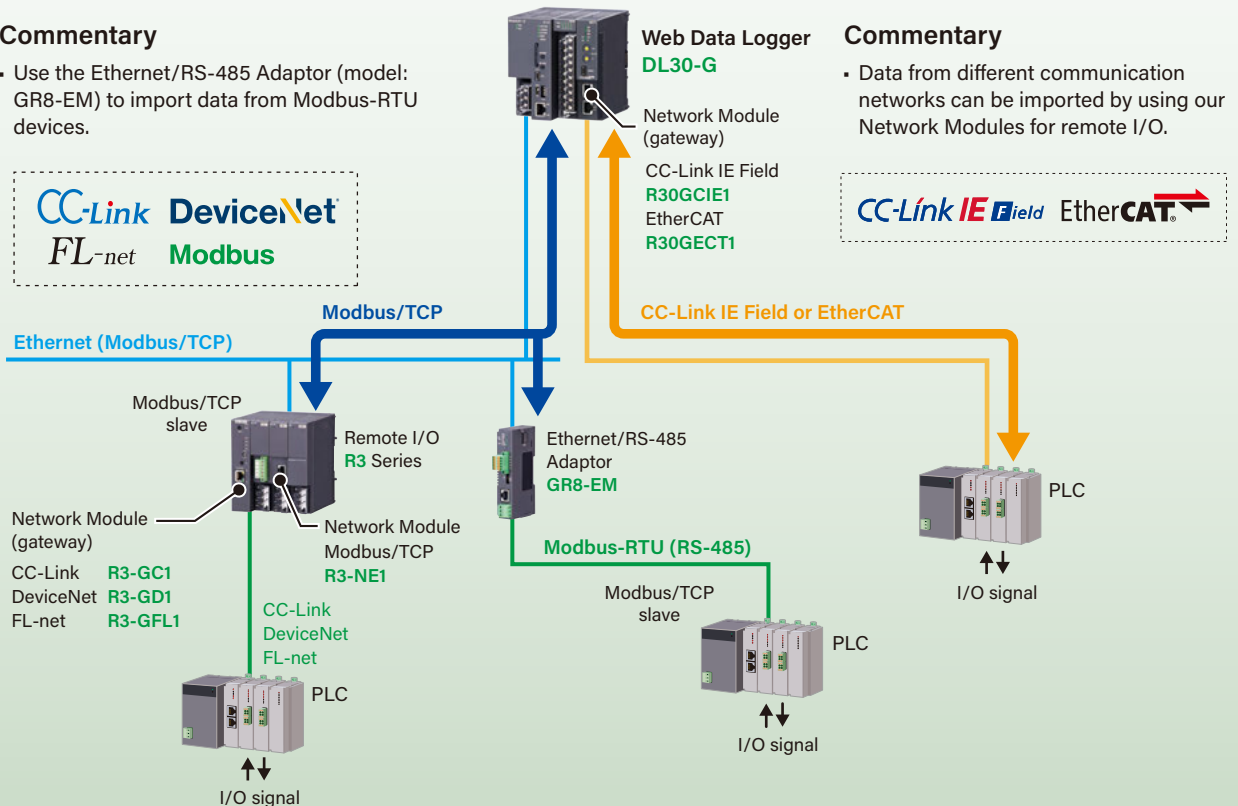

Commentary

- Data from different communication networks can be imported by using our Network Modules for remote I/O.



4 Retrieving signals from SLMP-compliant devices and PLCs

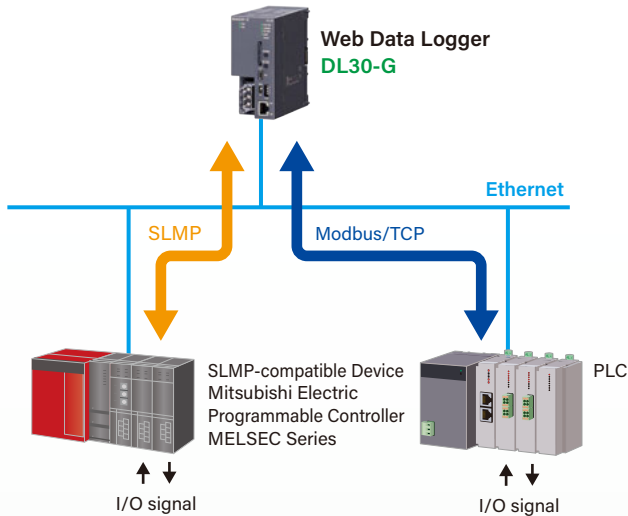

Commentary

- Retrieves I/O signals and internal data of SLMP-compliant PLCs.
- Connecting to a Remote I/O or PLC as a Modbus/TCP master allows data retrieval from other controllers.

SLMP: Seamless Message Protocol (A common protocol that seamlessly links CC-Link IE and Ethernet products)

5 I/O signals are retrieved using the 900-920 MHz ISM Band Multi-hop Wireless System.

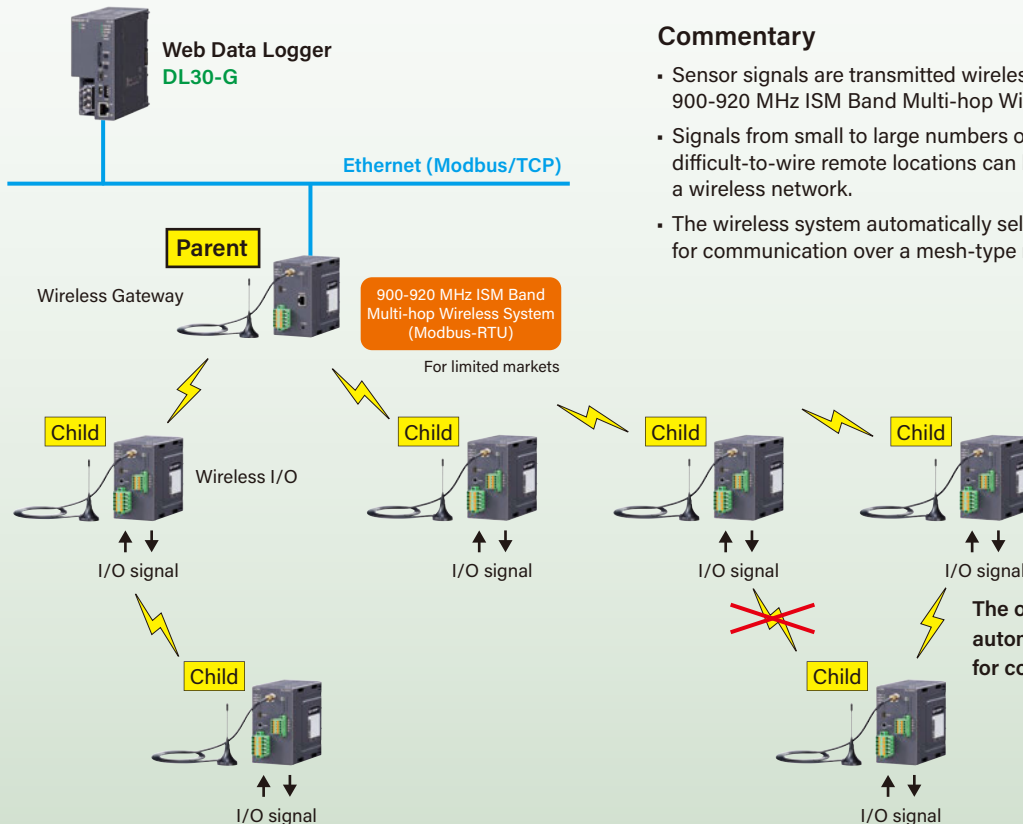

Commentary

- Sensor signals are transmitted wirelessly by combining the 900-920 MHz ISM Band Multi-hop Wireless System.
- Signals from small to large numbers of points and from difficult-to-wire remote locations can be easily retrieved via a wireless network.
- The wireless system automatically selects the optimal route for communication over a mesh-type network.

IP Telemeter Configuration Example

IP Telemeter (I/O mapping) Configuration with the DL30-G

Commentary

- The DL30-G units share data as IP telemeters, handling input/output signals.
- Communication is possible not only between the master and slave stations but also between different slave stations.
- Alarm monitoring can be performed by the DL30-G, and alarm output can be sent to other DL30-G units to enable contact output.
- An email notification can also be sent in the event of an alarm or abnormal communication with other stations.
- Data collected by the DL30-G is saved as logging and report files (in CSV format).

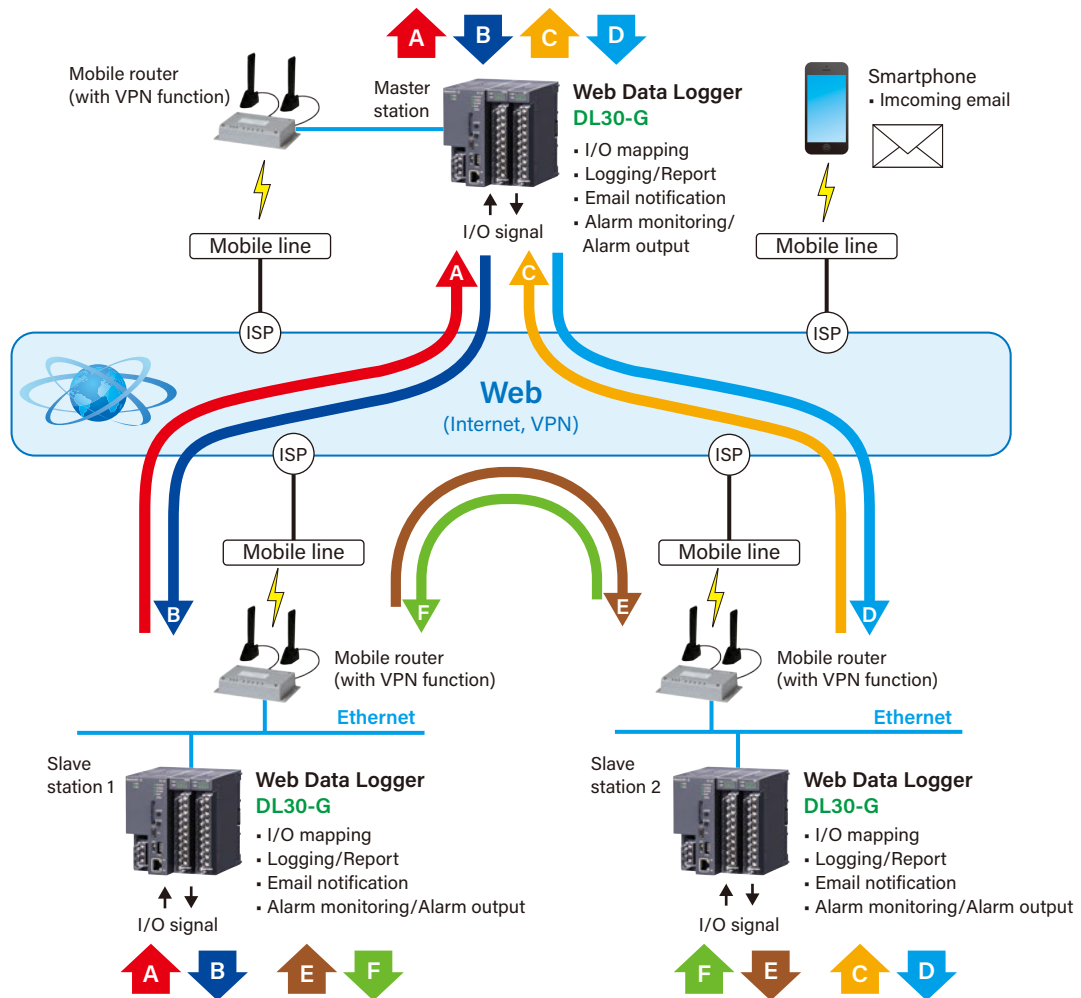

A fixed IP address or dynamic DNS service must be registered for system setup.

Unlike services using leased lines, Internet and mobile lines may not guarantee a 24-hour continuous connection.

For details, check with your service contractor.

Application Examples

Proposals for machinery and equipment manufacturers

By attaching the DL30-G to existing processing machinery or production equipment, your quality control center can monitor the production equipment's operation history data in real time via the Internet. The DL30-G plays a major role in anomaly detection, prediction, and preventive maintenance.

Generator monitoring example

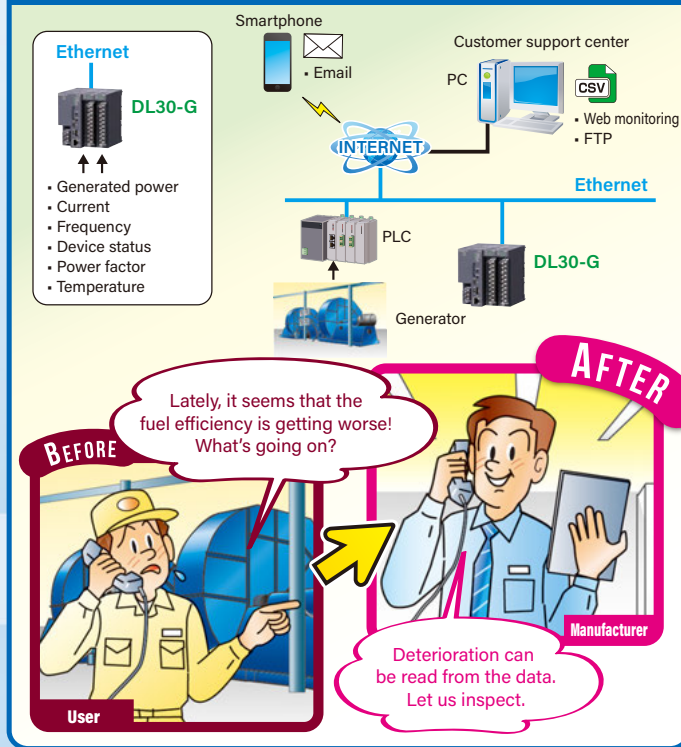

Extruder monitoring example

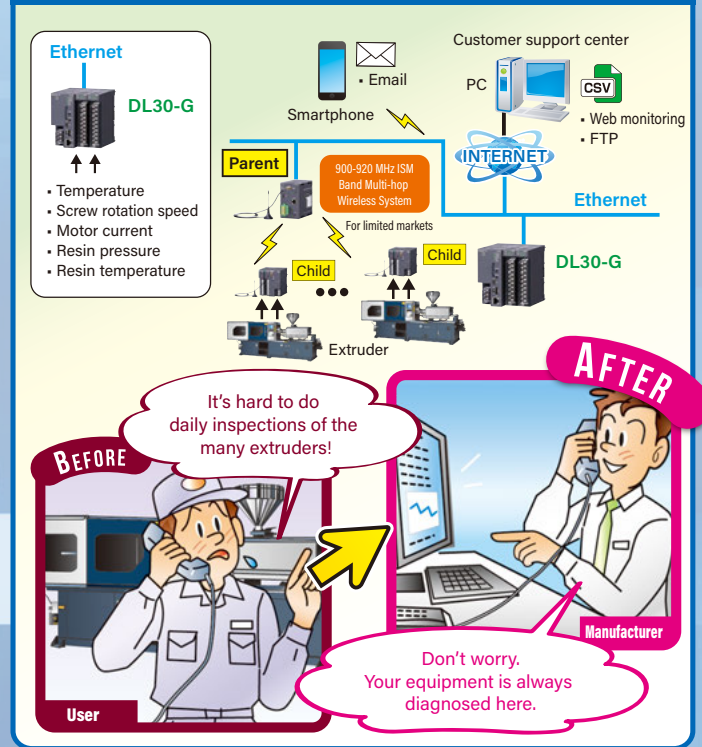

Building maintenance example

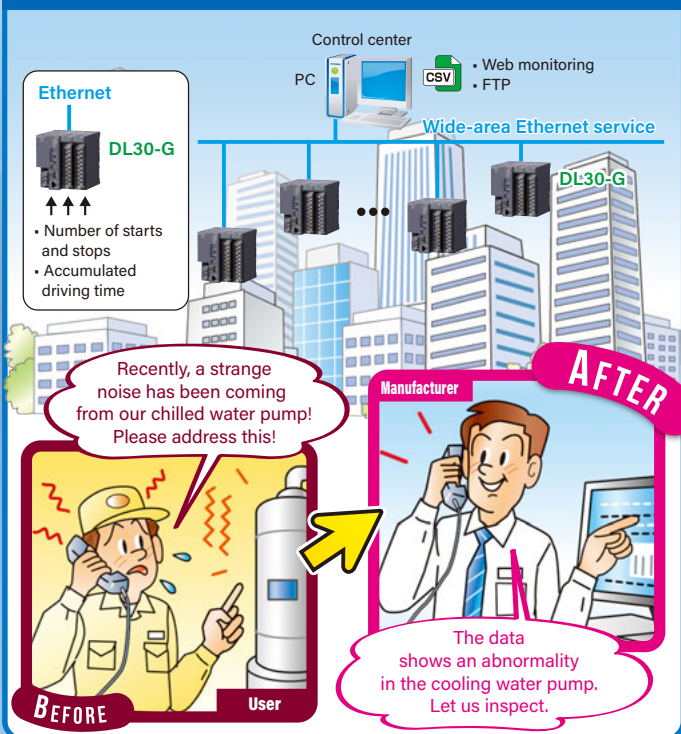

Compressor example

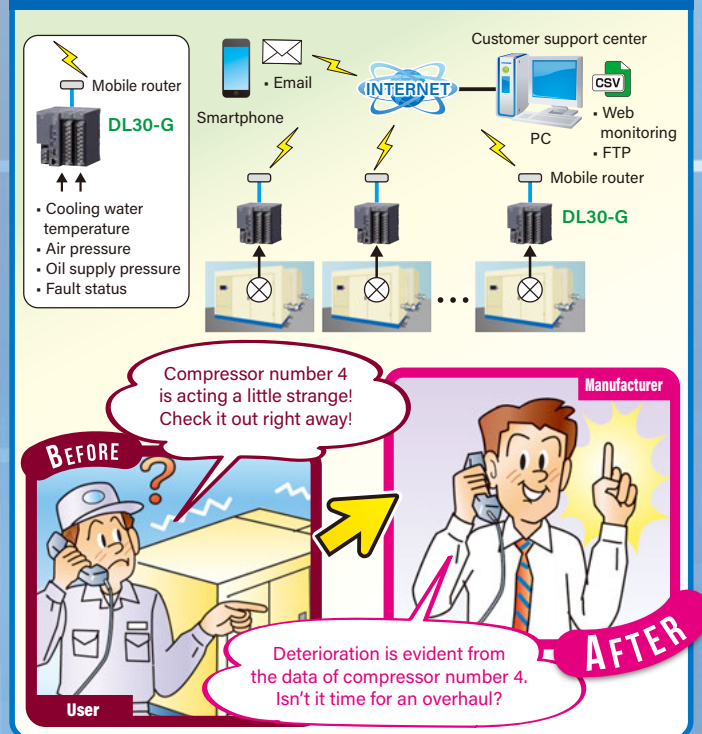

Application Examples

Proposals for machinery and equipment users

By attaching the DL30-G to each processing machine or production facility currently in operation, measurement data during the operation of each production or utility facility can be monitored in real time from a central monitoring room in the plant or via the Internet.

This frees you from the need for manual inspections and handwritten maintenance records.

Boiler example

Ethernet
DL30-G

- Gas pressure
- Components of exhaust gas
- Temperature

Smartphone
• Email

INTERNET

PC
• Web monitoring
• FTP

Ethernet

DL30-G

Boiler

BEFORE

Managing the operation of the boiler is challenging!

AFTER

It automates everything, from monitoring operational status to creating reports! In the event of an anomaly, we will be notified via email!

Solar power generation system

Mobile router

DL30-G

- Generated power
- Solar radiation intensity
- Outside temperature
- Information on power conditioners and other equipment

INTERNET

PC
• Web monitoring
• FTP

Mobile router

DL30-G

BEFORE

Surveying the extensive solar power system is a challenging task!

AFTER

In the event of an abnormality, we receive an email, and the data is saved in the DL30-G, which is very convenient.

Drain pump system for sewage

Mobile router

DL30-G

- Water level
- Inflow status
- Outflow status
- Running status
- Failure status

Mobile router

Monitoring box

INTERNET

PC
• Web monitoring
• FTP

Inflow line

Outflow line

Underwater pump

BEFORE

Manually inspecting each submersible pump and handwriting reports is laborious!

AFTER

With the DL30-G, centralized monitoring becomes straightforward, and reports are generated automatically!

Automatic electricity meter reading at tenant buildings

Router

DL30-G

- Energy pulse (Each tenant)
- Common area
- Power

Office

Office

Cram school

Beauty salon

Bookstore

Coffee shop

Tenants

INTERNET

PC
• Web monitoring
• FTP

DL30-G

BEFORE

It's hard work going around for monthly checkups!

AFTER

The electricity usage of all tenants can be managed on the server, making automatic billing and debiting of charges possible.

Hardware and Configuration

The DL30-G is used in combination with the Remote I/O R30 Series I/O Modules and Base.

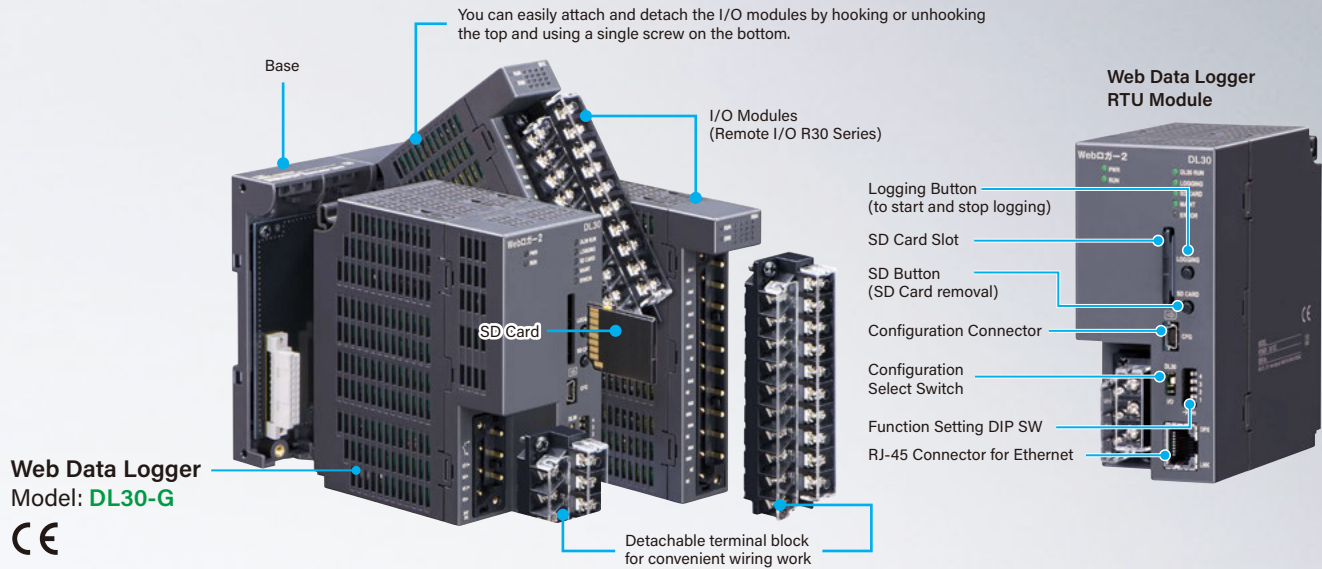

Types of I/O Modules and Bases

Analog Input Module

Function	Model	CE
DC VOLTAGE/CURRENT INPUT MODULE (2 points, isolated)	R30SV2	✓
DC VOLTAGE/CURRENT INPUT MODULE (4 points, isolated)	R30SV4	✓
HIGH-SPEED DC VOLTAGE/CURRENT INPUT MODULE (4 points, isolated)	R30SVF4	✓
THERMOCOUPLE INPUT MODULE (4 points, isolated)	R30TS4	✓
RTD INPUT MODULE (4 points, isolated)	R30RS4	✓
AC CURRENT INPUT MODULE (4 points, isolated, clamp-on current sensor type CLSE use)	R30CT4E	✓
POTENTIOMETER INPUT MODULE (4 points, isolated)	R30MS4	✓

Analog Output Module

Function	Model	CE
DC VOLTAGE OUTPUT MODULE (4 points, isolated)	R30YV4	✓
DC CURRENT OUTPUT MODULE (4 points, isolated)	R30YS4	✓

Discrete I/O Module

Function	Model	CE
DISCRETE INPUT MODULE (Di 16 points; with external excitation supply)	R30XN16A	✓
DISCRETE OUTPUT MODULE (NPN transistor output, 16 points)	R30YN16A	✓
DISCRETE OUTPUT MODULE (PNP transistor output, 16 points)	R30YN16C	✓

Pulse Input Module

Function	Model	CE
TOTALIZED PULSE INPUT MODULE (Pi 2 points, 32 bits)	R30PA2	✓

Universal Input Module

Function	Model	CE
UNIVERSAL INPUT MODULE (2 points, isolated) DC current input / DC voltage input / Thermocouple input / RTD input / Potentiometer input	R30US2	✓
UNIVERSAL INPUT MODULE (4 points, isolated) DC current input / DC voltage input / Thermocouple input / RTD input / Potentiometer input	R30US4	✓

Network Module (gateway)

Function	Model	CE
CC-Link INTERFACE MODULE (CC-Link IE Field network)	R30GCIE1	✓
EtherCAT INTERFACE I/O MODULE (EtherCAT)	R30GECT1	✓

Base and Accessory

Function	Model	CE
INSTALLATION BASE (0 slot)	R30BS00	✓
INSTALLATION BASE (2 slots)	R30BS02	✓
INSTALLATION BASE (4 slots)	R30BS04	✓
INSTALLATION BASE (6 slots)	R30BS06	✓
INSTALLATION BASE (8 slots)	R30BS08	✓
INSTALLATION BASE (12 slots)	R30BS12	✓
INSTALLATION BASE (16 slots)	R30BS16	✓
BLANK FILLER MODULE	R30DM	--

About the Software

You can download the configurator software DL30GCFG and RCFG for the DL30-G and the R30, respectively, as well as the user-defined screen creation software DL30 Web Designer for the DL30-G, from our website.

To connect the devices to a PC, use a commercially available USB 2.0 compatible cable with a mini-B type connector, no longer than 5.0 m).

- An SD card is required to save data. Use a specified SD card. You can also purchase SD cards from us. Please contact us for more information.

Main Specifications

GENERAL SPECIFICATIONS

Connection

RUN contact output, power supply: M3 separable screw terminal
(torque 0.5 N-m)

Ethernet: RJ-45 modular jack

Internal bus: Via the Installation Base (model: R30BS)

Internal power supply: Via the Installation Base (model: R30BS)

Solderless terminal (recommended manufacturer):

J.S.T. Mfg. Co., Ltd., NICHIFU Co., Ltd.

(Ones with insulation sleeve do not fit.)

Applicable wire size: 0.25 – 0.75 mm²

Screw terminal: Nickel-plated steel

Housing material: Flame-resistant resin (gray)

Max. number of R30 I/O modules: 16

(Max. consumption current of I/O modules: 500 mA)

Isolation: Ethernet to internal bus or internal power to RUN contact output to power supply to FE

Calendar clock: Year (4 digits), month, date, day, hour, minute, second

Internal bus communication cycle: Approx. ≤ 1 msec.

(when max. No. of modules connected)

Status Indicator LEDs: PWR, RUN, DL30 RUN, LOGGING, SD CARD, MAINT, ERROR (Refer to Operating Manual for details)

RUN contact output

RUN contact turns ON in normal conditions, and turns OFF when the power is not supplied or when an error occurs (internal memory error, SD card error, or R30 module error).

Rated load: 250 V AC @ 0.5 A (cos ϕ = 1)

30 V DC @ 0.5 A (resistive load)

(Less than 50 V AC to conform with EU Directive)

INSTALLATION

Power input: 24 V DC

(Operational voltage range: $\pm 10\%$; ripple 10 %p-p max.)

Power consumption: Approx. 18 W 24 V DC (at output current max. 500 mA)

Approx. 5.3 W (at single mounting)

Internal power

Max. rated output voltage / current: 21 V DC / 500 mA

Total current consumed at the R30 I/O modules used in combination with DL30 must be within above current.

Operating temperature: 0 to 50°C (32 to 122°F)

Storage temperature: -10 to +60°C (14 to 140°F)

Operating humidity: 10 to 90 %RH (non-condensing)

Atmosphere: No corrosive gas or heavy dust

Mounting: Installation Base (model: R30BS)

Weight: 300 g (0.66 lb)

PERFORMANCE

Calendar clock (with battery backup)

Accuracy: Monthly deviation 2 minutes at 25°C

Back up period: Approx. 2 years at 25°C

Battery: Primary lithium battery (non-removable)

(In order to prevent battery drain, battery back up is OFF at factory default. Turn it ON prior to start using.)

Insulation resistance: $\geq 100 \text{ M}\Omega$ with 500 V DC

Dielectric strength: 1500 V AC @ 1 minute (Ethernet to internal bus or internal power to RUN contact output to power supply to FE)

EXTERNAL DIMENSIONS unit: mm (inch)

When the DL30-G and two I/O modules are attached to the base.

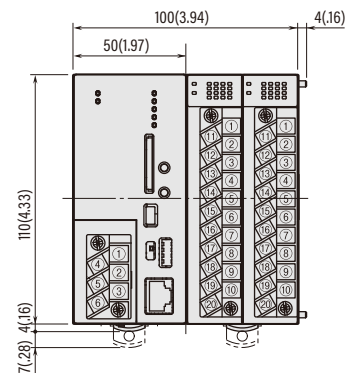

FRONT VIEW

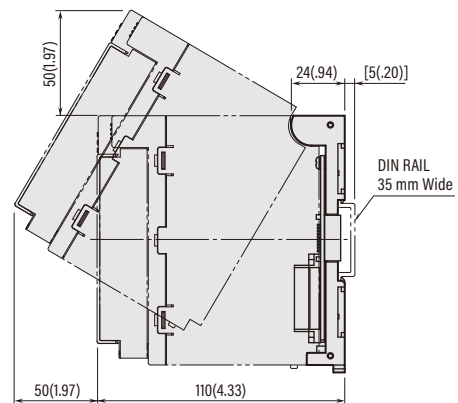

SIDE VIEW



Website



Request Info

Your local representative: