

BEFORE USE

Thank you for choosing us. Before use, please check contents of the package you received as outlined below. If you have any problems or questions with the product, please contact our sales office or representatives.

■ PACKAGE INCLUDES:

- Signal conditioner(1)
- Mounting screw (M3.5 × 10).....(2)

■ MODEL NO.

Confirm Model No. marking on the product to be exactly what you ordered.

■ INSTRUCTION MANUAL

This manual describes necessary points of caution when you use this product, including installation, connection and basic maintenance procedures.

POINTS OF CAUTION

■ GENERAL PRECAUTIONS

- Before you remove the unit or mount it, turn off the input signal for safety.

■ ENVIRONMENT

- Indoor use.
- When heavy dust or metal particles are present in the air, install the unit inside proper housing with sufficient ventilation.
- Do not install the unit where it is subjected to continuous vibration. Do not subject the unit to physical impact.
- Environmental temperature must be within -5 to +55°C (23 to 131°F) with relative humidity within 30 to 90% RH in order to ensure adequate life span and operation.

■ WIRING

- Do not install cables close to noise sources (relay drive cable, high frequency line, etc.).
- Do not bind these cables together with those in which noises are present. Do not install them in the same duct.

■ AND

- The unit is designed to function as soon as the input signal is supplied, however, a warm up for 10 minutes is required for satisfying complete performance described in the data sheet.
- DO NOT apply the input signal when there is no supply pressure.
- The transducer produces no output when the input goes below approximately 3.5mA.

COMPONENT IDENTIFICATION

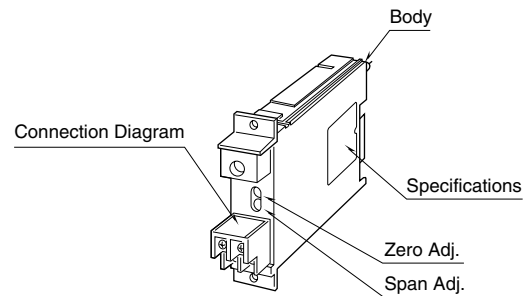

INSTALLATION

Use Standard Rack (model: 10BXx).

TERMINAL CONNECTIONS

Connect the unit as in the diagram below or refer to the connection diagram on the front of the unit.

EXTERNAL DIMENSIONS unit: mm (inch)

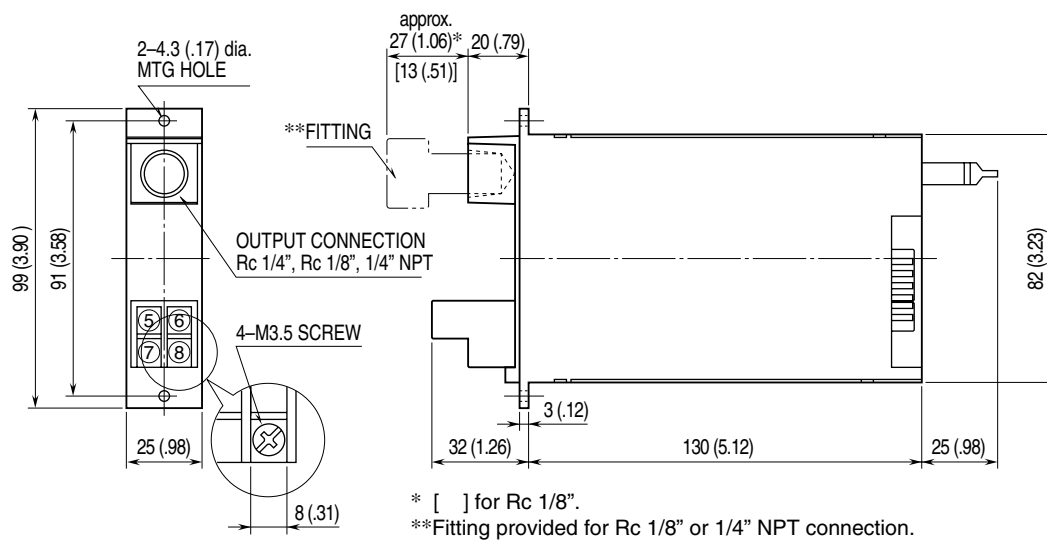

CONNECTION DIAGRAM

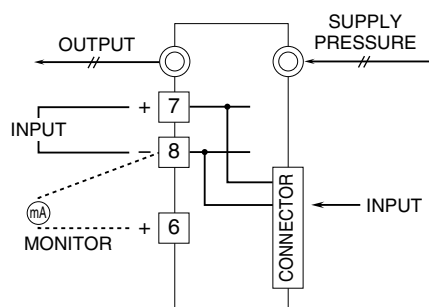

WIRING INSTRUCTIONS

■ SCREW TERMINAL

Torque: 0.8 N·m

PIPING

Blow the piping before the Transducer installation in order to remove dust in it. Use dry air containing no carbon black or other foreign particles. To ensure reliability, use an air filter (0.01 microns). Be sure that no water, oil or dust particles enter the transducer by way of supply air. The pneumatic inlet is female screwed of Rc 1/4" (Rc 1/8" or 1/4" NPT optional with a fitting). Tightening torque is at the maximum of 12 N·m. Check that there is no air leak at the connection after sealing it.

Be aware that attaching/detaching the output piping with the input signal applied, or sudden change in the output pressure affects outputs of other I/P Transducers. Such effects are especially great when the supply pressure piping is of small size.

CHECKING

- 1) Terminal wiring: Check that all cables are correctly connected according to the connection diagram.
- 2) Input: Check that the input signal is within 0 – 100% of the full-scale.
- 3) Check output air pressure.
- 4) Check supply pressure.
- 5) Check that there is no air leak at the connections.

Note: The transducer constantly consumes some air pressure (6 Nl/min. typical) at the nozzle of the nozzle flapper section where a leaking air sound may be heard during normal operation.

ADJUSTMENT PROCEDURE

This unit is calibrated at the factory to meet the ordered specifications, therefore you usually do not need any calibration.

For matching the signal to a receiving instrument or in case of regular calibration, adjust the output as explained in the following.

■ HOW TO CALIBRATE THE OUTPUT SIGNAL

Use a signal source and measuring instruments of sufficient accuracy level. Turn the input signal on and warm up for more than 10 minutes.

- 1) ZERO: Apply 0% input and adjust output to 0%.
- 2) SPAN: Apply 100% input and adjust output to 100%.
- 3) Check ZERO adjustment again with 0% input.
- 4) When ZERO value is changed, repeat the above procedure 1) – 3).

MAINTENANCE

Regular calibration procedure is explained below:

■ CALIBRATION

Warm up the unit for at least 10 minutes. Apply 0%, 25%, 50%, 75% and 100% input signal. Check that the output signal for the respective input signal remains within accuracy described in the data sheet. When the output is out of tolerance, recalibrate the unit according to the "ADJUSTMENT PROCEDURE" explained earlier.

TESTING

Operation testing is available without disturbing the actual transducer input signal (DCS computer output) in following the procedure described below:

- 1) Close across the terminal 7 – 8.
- 2) Connect the current generator's positive (+) terminal to the transducer's terminal 7, the negative (–) to the terminal 6.

LIGHTNING SURGE PROTECTION

We offer a series of lightning surge protectors for protection against induced lightning surges. Please contact us to choose appropriate models.