

STANDARD RACK (pressure supply)
(Fujitsu FCN type I/O connector)

MODEL 18KBXCA-U1

BEFORE USE

Thank you for choosing us. Before use, check the contents of the package you received.
If you have any problems or questions with the product, please contact our sales office or representatives.

INSTALLATION

■ **ENVIRONMENT**

- Indoor use
- When heavy dust or metal particles are present in the air, install the unit inside proper housing with sufficient ventilation.
- Do not install the unit where it is subjected to continuous vibration. Do not apply physical impact to the unit.
- Environmental temperature must be within -5 to +55°C (23 to 131°F) with relative humidity within 30 to 90% RH in order to ensure adequate life span and operation.
- Be sure that the ventilation slits are not covered with cables, etc.

MOUNTING REQUIREMENTS mm (inch)

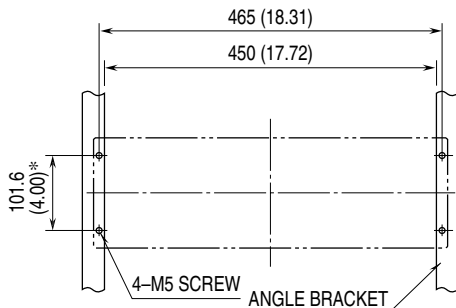

Observe an appropriate wiring space over and below.
*100 (3.94) for JIS standard

TERMINAL CONNECTIONS

Connect the unit as in the diagram below.

■ **CONNECTION DIAGRAM**

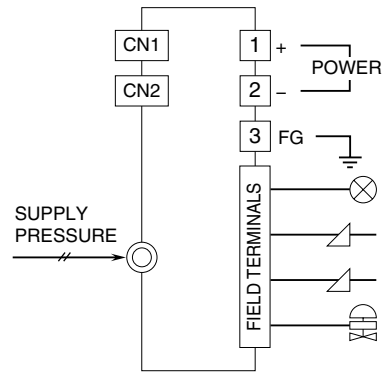

■ **CONNECTOR PIN ASSIGNMENT**

I/O connector: OTAX N365P040AU
(Fujitsu FCN-365P040-AU...discontinued)

CN1: output 1 or input
CN2: output 2

PIN NO.	ASSIGNMENT	PIN NO.	ASSIGNMENT
A 1	ch. 1 +	B 1	ch. 1 -
A 2	ch. 2 +	B 2	ch. 2 -
A 3	ch. 3 +	B 3	ch. 3 -
A 4	ch. 4 +	B 4	ch. 4 -
A 5	ch. 5 +	B 5	ch. 5 -
A 6	ch. 6 +	B 6	ch. 6 -
A 7	ch. 7 +	B 7	ch. 7 -
A 8	ch. 8 +	B 8	ch. 8 -
A 9	ch. 9 +	B 9	ch. 9 -
A10	ch.10 +	B10	ch.10 -
A11	ch.11 +	B11	ch.11 -
A12	ch.12 +	B12	ch.12 -
A13	ch.13 +	B13	ch.13 -
A14	ch.14 +	B14	ch.14 -
A15	ch.15 +	B15	ch.15 -
A16	ch.16 +	B16	ch.16 -

A17 - A20, B17 - B20: Unused

Pin assignment is common to both CN1 and CN2.

PNEUMATIC CONNECTIONS

Select a proper pipe diameter for the required flow volume. For 16 positions, where 960 NI / min. of air flow is required, use two copper or nylon pipes having an internal diameter of 10 mm or larger. Install the pipes to right before the pneumatic connection and make the pipe length from the air header within 3 m.

For 9 positions or less, necessary flow volume can be supplied with just one pipe of the above.

Insert a stopping valve at the pipe connection to the air header for easy testing and maintenance.

The pneumatic connections are female screwed of Rc 3/8".

Use dry air containing no carbon black or other foreign particles. To ensure reliability, use an air filter (0.01 microns).

Be sure that no water, oil or dust particles enter the signal conditioners or transducers by way of supply air.

Before connecting pipes, blow air through each of them at least for 3 minutes at 140 kPa (1.4 kgf/cm², 1.4 bar or 20 psig).

Check that there is no air leak at the connection after sealing it.

CHECKING

- 1) Terminal wiring: Check that all cables are correctly connected according to the connection diagram.
- 2) Power input voltage: Check voltage across terminals 1 (+) – 2 (-). Be sure that the ripple level is 10% p-p or less.
- 3) Supply pressure: 140 kPa (1.4 kgf/cm², 1.4 bar or 20 psig)
- 4) Pneumatic connection: Be sure that there is no air leak at the connection.
- 5) Installation & environment: Check ambient temperature. Also check that there are no excessive dust particles around. Check that there is no vibration.