

**BEFORE USE ....**

Thank you for choosing us. Before use, please check contents of the package you received as outlined below. If you have any problems or questions with the product, please contact our sales office or representatives.

**■ PACKAGE INCLUDES:**

Signal conditioner (body + CJC sensor).....(1)

**■ MODEL NO.**

Confirm Model No. marking on the product to be exactly what you ordered.

**■ INSTRUCTION MANUAL**

This manual describes necessary points of caution when you use this product, including installation, connection and basic maintenance procedures.

**POINTS OF CAUTION**

**■ POWER INPUT RATING & OPERATIONAL RANGE**

- Locate the power input rating marked on the product and confirm its operational range as indicated below:  
 24V DC rating: 24V ±10%,  
 approx. 35mA with voltage output  
 approx. 65mA with current output

**■ GENERAL PRECAUTIONS**

- Before you remove the unit or mount it, turn off the power supply and input signal for safety.

**■ ENVIRONMENT**

- Indoor use.
- When heavy dust or metal particles are present in the air, install the unit inside proper housing with sufficient ventilation.
- Do not install the unit where it is subjected to continuous vibration. Do not subject the unit to physical impact.
- Environmental temperature must be within -5 to +55°C (23 to 131°F) with relative humidity within 30 to 90% RH in order to ensure adequate life span and operation.

**■ WIRING**

- Do not install cables close to noise sources (relay drive cable, high frequency line, etc.).
- Do not bind these cables together with those in which noises are present. Do not install them in the same duct.

**■ AND ....**

- The unit is designed to function as soon as power is supplied, however, a warm up for 10 minutes is required for satisfying complete performance described in the data sheet.

**COMPONENT IDENTIFICATION**

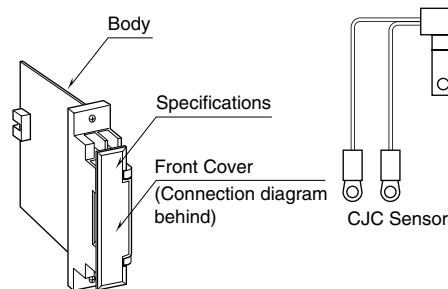

**■ FRONT VIEW (with cover open)**

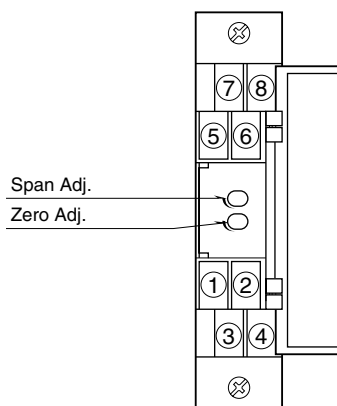

**INSTALLATION**

Use Standard Rack (model: 18KBXx).

## TERMINAL CONNECTIONS

Connect the unit as in the diagram below or refer to the connection diagram behind the front cover.

Attach the CJC sensor together with input wiring to the input terminals. The CJC sensor is not interchangeable. Check that its serial number is identical to that of the unit.

### EXTERNAL DIMENSIONS unit: mm (inch)

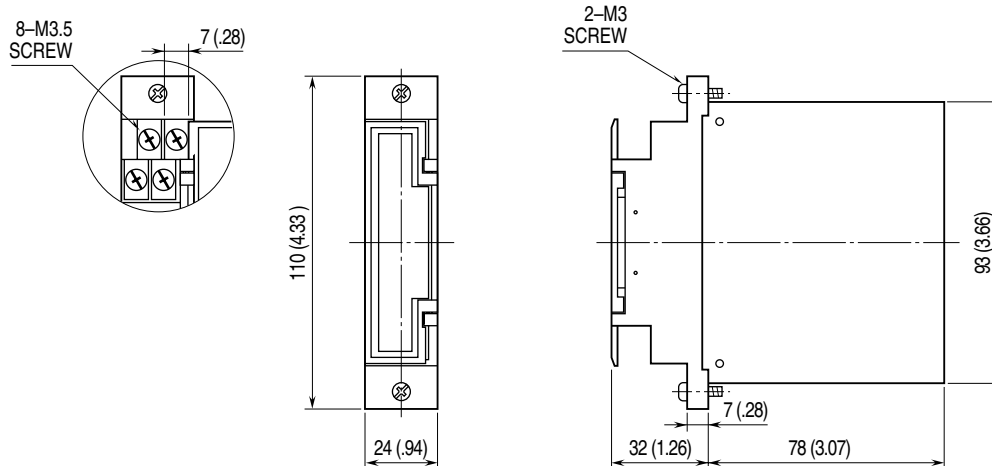

### CONNECTION DIAGRAM

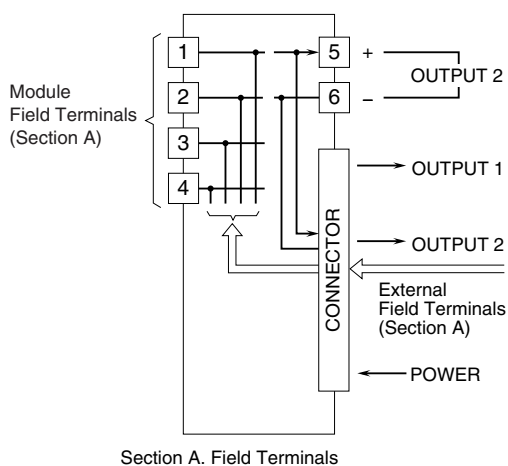

### TERMINAL ASSIGNMENTS

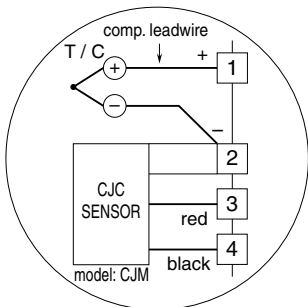
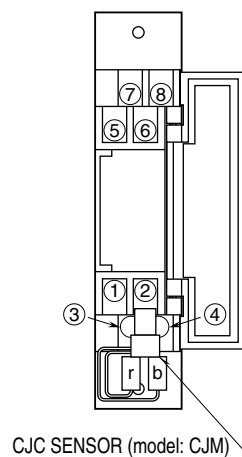

Note 1: Use either of module or external field terminals.

Note 2: For OUTPUT 2 with current output, use either of terminals on the front or connector on the rear.

## WIRING INSTRUCTIONS

### ■ SCREW TERMINAL

Torque: 0.8 N·m

## CHECKING

- 1) Terminal wiring: Check that all cables are correctly connected according to the connection diagram.
- 2) Power input voltage: Check voltage supplied to the rack (model: 18KBXx). For the DC power source, be sure that the ripple level is within 10% p-p.
- 3) Input: Check that the input voltage is within 0 – 100% of full-scale.  
If the thermocouple or its extension wires are broken, the output goes over 100% (below 0% with downscale) due to burnout function. Check leadwires in such a case.
- 4) Output: Check that the load resistance meets the described specifications shown below.

## ADJUSTMENT PROCEDURE

This unit is calibrated at the factory to meet the ordered specifications, therefore you usually do not need any calibration.

For matching the signal to a receiving instrument or in case of regular calibration, adjust the output as explained in the following.

### ■ HOW TO CALIBRATE THE OUTPUT 1

Use a signal source and measuring instruments of sufficient accuracy level. Turn the power supply on and warm up for more than 10 minutes.

- 1) ZERO: Apply 0% input and adjust output to 0%.
- 2) SPAN: Apply 100% input and adjust output to 100%.
- 3) Check ZERO adjustment again with 0% input.
- 4) When ZERO value is changed, repeat the above procedure 1) – 3).
- 5) No need of adjustments for the Output 2.

Note: The factory calibration is performed with the input signals from external field terminals. Recalibration is needed when you use module field terminals.

## MAINTENANCE

Regular calibration procedure is explained below:

### ■ CALIBRATION

Warm up the unit for at least 10 minutes. Apply 0%, 25%, 50%, 75% and 100% input signal. Check that the output signal for the respective input signal remains within accuracy described in the data sheet. When the output is out of tolerance, recalibrate the unit according to the “ADJUSTMENT PROCEDURE” explained earlier.

## LIGHTNING SURGE PROTECTION

We offer a series of lightning surge protector for protection against induced lightning surges. Please contact us to choose appropriate models.