

**ISOLATION AMPLIFIER**  
(current output, output isolation)

MODEL **20VS2-4**

**BEFORE USE ....**

Thank you for choosing us. Before use, please check contents of the package you received as outlined below.

If you have any problems or questions with the product, please contact our sales office or representatives.

■ **PACKAGE INCLUDES:**

Amplifier ..... (1)

■ **MODEL NO.**

Confirm Model No. marking on the product to be exactly what you ordered.

■ **INSTRUCTION MANUAL**

This manual describes necessary points of caution when you use this product, including installation, connection and basic maintenance procedures.

**POINTS OF CAUTION**

■ **CONFORMITY WITH EC DIRECTIVES**

The compliance with EC Directive is confirmed with mounting on a printed wiring board without other devices. The actual installation environments such as the connected wires and mounted components on the printed wiring board may affect the protection level of this module. Confirm the CE requirements in regard to the whole system and employ additional protective measures to ensure CE conformity. The reference voltage source\* shall be used in the printed wiring board on which the unit is mounted.

\*The total length of the wiring shall not be more than 3 m.

■ **POWER INPUT RATING & OPERATIONAL RANGE**

- Locate the power input rating marked on the product and confirm its operational range as indicated below:  
15V DC  $\pm 2\%$ , approx. 28mA with 20mA output
- Surge in the power supply can be cut off as the surge absorbers are installed in the power supply, input and output. When there is spike noises in the power, make a filter with an appropriate capacitor and inductor to cut it off.

■ **ENVIRONMENT**

- Indoor use
- When heavy dust or metal particles are present in the air, install the unit inside proper housing with sufficient ventilation.
- Do not install the unit where it is subjected to continuous vibration. Do not subject the unit to physical impact.
- Environmental temperature must be within 0 to 60°C (32 to 140°F) with relative humidity within 30 to 90% RH in order to ensure adequate life span and operation.

■ **WIRING**

- Do not install cables (power supply, input and output) close to noise sources (relay drive cable, high frequency line, etc.).
- Do not bind these cables together with those in which noises are present. Do not install them in the same duct.
- Mounting multiple isolator modules on single printed wiring board could cause beat. In such case, use the way shown as below to make the power supply oscillation frequency of each module to a same one for prevention.

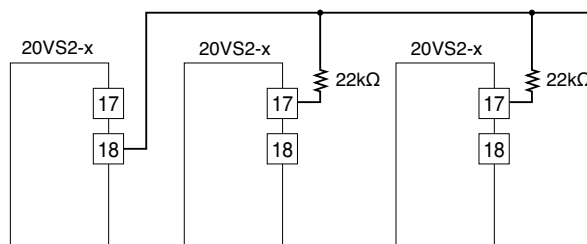

■ **INSTALLING THE MODULE**

When it is installed on the printed wiring board, land diameter  $\phi 1.5$  and through-hole  $\phi 0.9$  are recommended.

■ **AND ....**

- The unit is designed to function as soon as power is supplied, however, a warm up for 10 minutes is required for satisfying complete performance described in the data sheet.
- With voltage output, do not leave the output terminals shortcircuited for a long time. The unit is designed to endure it without breakdown, however, it may shorten appropriate life duration.

## TERMINAL CONNECTIONS

### EXTERNAL DIMENSIONS mm (inch)

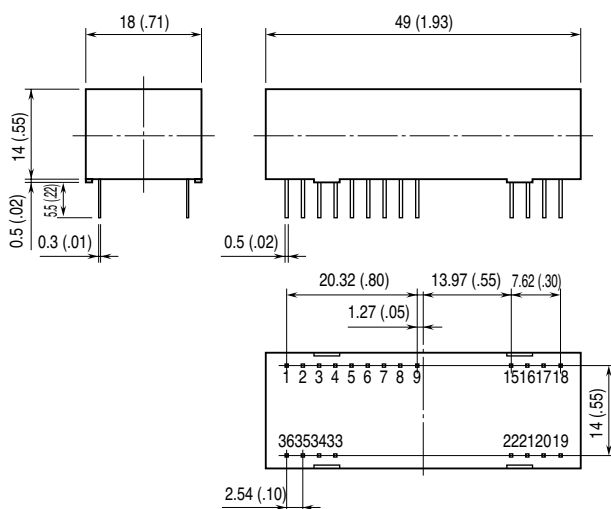

### PIN ASSIGN

NO.	FUNCTION
1	Current Output (+)
2	Current Output (-)
3	Voltage Output (+)
4	Output Amplification
5	Voltage Output (-)
6	NC
7	Reference Voltage Source (+)
8	Reference Voltage Source (-)
9	Reference Voltage Source (COM)
15	Power Supply (+)
16	Power Supply (-)
17	Synchronous Input
18	Synchronous Output
19	Input (-)
20	Input (+)
21	Input Amplification
22	Input Attenuation
33	NC
34	NC
35	NC
36	NC

### TERMINAL ASSIGNMENTS

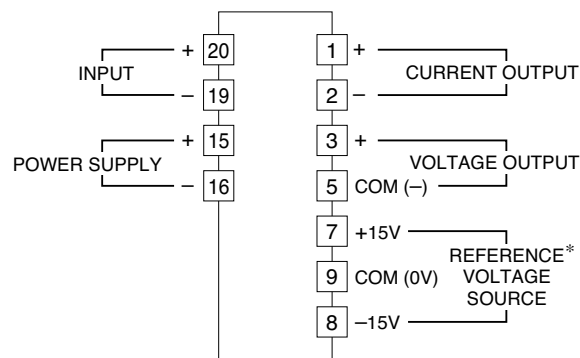

\*To be used in the printed wiring board on which the unit is mounted.

## CHECKING

- 1) Terminal wiring: Check that all cables are correctly connected according to the connection diagram.
- 2) Power input voltage: Check voltage across the pins.
- 3) Input: Check that the input signal is within 0 – 100% of the full-scale.
- 4) Output: Check that the load resistance meets the described specifications.

## ADJUSTMENT PROCEDURE

### ■ ADJUSTMENT AT INPUT

To adjust zero and span, use external adjusters.

In order to shift the zero at input, supply reference voltage to pin 21. The following formula shows how much the zero shifts. (input signal at pin 20 =  $V_{IN}$ ; output signal at pin 1 =  $V_{OUT}$ ; reference voltage =  $V_{REF}$ ; zero shift =  $V_{OUTSHIFT}$ .)

$$V_{OUTSHIFT} = - \left( \frac{10k\Omega}{R1} \right) \times V_{REF}$$

In order to attenuate input signal, connect a resistor to pin 22. The following formula shows the attenuated output.

$$V_{OUT} = \left( \frac{R2}{R2 + 10k\Omega} \right) \times V_{IN}$$

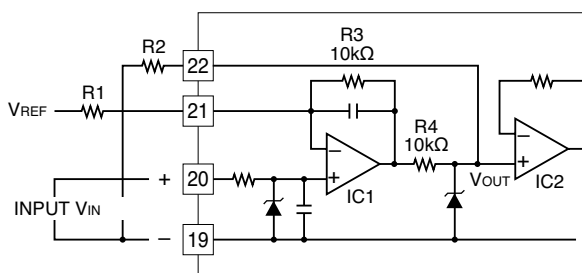

External resistors and adjusters make zero and span adjustment available.

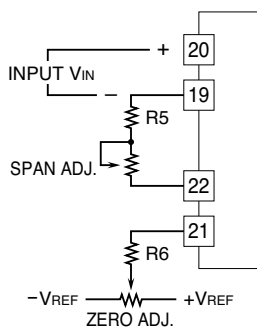

### ■ ADJUSTMENT AT OUTPUT

This unit has current and voltage outputs.

An external resistor,  $R8$  ( $k\Omega$ ) connecting across the pin 5 and pin 4 amplifies voltage output as following formula. ( $R8 \geq 869 k\Omega$ )

$$V_{OUT} = \left( \frac{10k\Omega}{R8} + 1 \right) \times V_{IN}$$

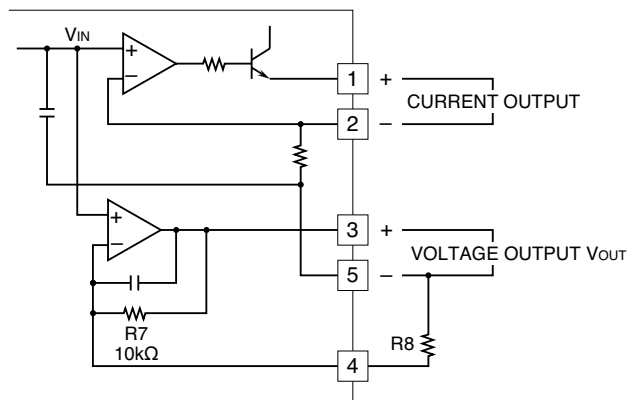

The minus terminals of current output and voltage output are not common. Do not use them at once.

## MAINTENANCE

Regular calibration procedure is explained below:

### ■ CALIBRATION

Warm up the unit for at least 10 minutes. Apply 0%, 25%, 50%, 75% and 100% input signal. Check that the output signal for the respective input signal remains within accuracy described in the data sheet.