

DC INPUT DIGITAL PANEL METER
(3 1/2 digit, without scaling)

MODEL

40LV**BEFORE USE**

Thank you for choosing us. Before use, please check contents of the package you received as outlined below.

If you have any problems or questions with the product, please contact our sales office or representatives.

■ PACKAGE INCLUDES:

Digital panel meter (body + mounting bracket × 2).....(1)
Engineering unit sticker label sheet.....(1)

■ MODEL NO.

Confirm Model No. marking on the product to be exactly what you ordered.

■ INSTRUCTION MANUAL

This manual describes necessary points of caution when you use this product, including installation, connection and basic maintenance procedures.

POINTS OF CAUTION**■ CONFORMITY WITH EU DIRECTIVES**

- The equipment must be installed such that appropriate clearance and creepage distances are maintained to conform to CE requirements. Failure to observe these requirements may invalidate the CE conformance.

■ POWER INPUT RATING & OPERATIONAL RANGE

- Locate the power input rating marked on the product and confirm its operational range as indicated below:
24V DC rating: 24V ±20%, approx. 0.5W

■ GENERAL PRECAUTIONS

- Before you remove the unit or mount it, turn off the power supply and input signal for safety.
- Be sure to put the terminal cover on while the power is supplied.

■ ENVIRONMENT

- Indoor use.
- When heavy dust or metal particles are present in the air, install the unit inside proper housing with sufficient ventilation.
- Do not install the unit where it is subjected to continuous vibration. Do not subject the unit to physical impact.
- Environmental temperature must be within 0 to 55°C (32 to 131°F) with relative humidity within 30 to 90% RH in order to ensure adequate life span and operation.
- Be sure that the ventilation slits are not covered with cables, etc.

■ WIRING

- Make sure for safety that only qualified personnel perform the wiring.
- Do not install cables close to noise sources (high frequency line, etc.).
- Do not bind these cables together with those in which noises are present. Do not install them in the same duct.

■ AND

- The unit is designed to function as soon as power is supplied, however, a warm up for 10 minutes is required for satisfying complete performance described in the data sheet.

COMPONENT IDENTIFICATION

■ TOP VIEW

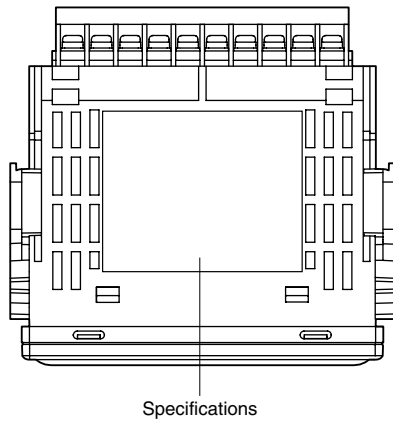

■ FRONT VIEW

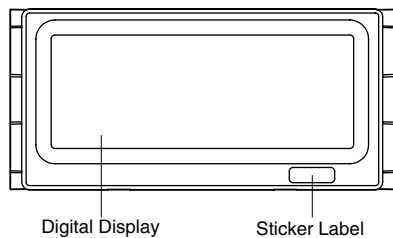

■ SIDE VIEW

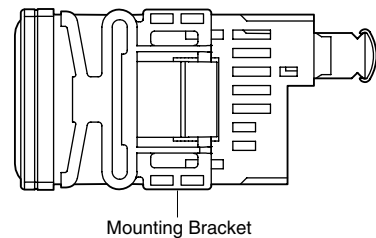

■ HOW TO REMOVE THE FRONT PANEL AT SPAN CALIBRATION

Hold up the front panel and remove it from downside.

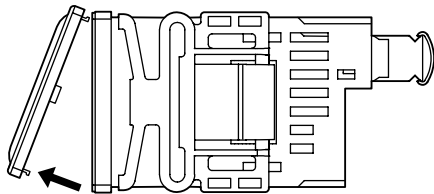

• View without the front panel

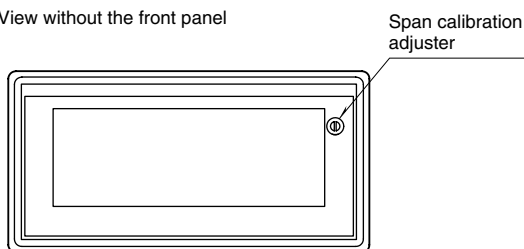

■ HOW TO MOUNT THE FRONT PANEL

- 1) Insert the front panel hook into the case upside slots of the unit.
- 2) Push the front panel hook into the case downside slots of the unit.

INSTALLATION

■ PANEL CUTOUT unit: mm

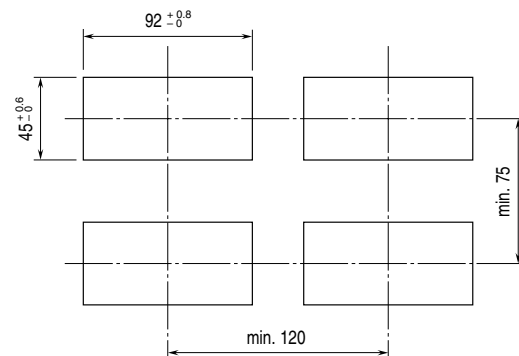

Panel thickness: 1.6 to 8.0 mm

■ HOW TO MOUNT THE UNIT ON A PANEL

- 1) Insert the unit into the panel cutout.
- 2) Push the mounting brackets into the grooves on both sides of the rear module, until they hit the panel's rear side.

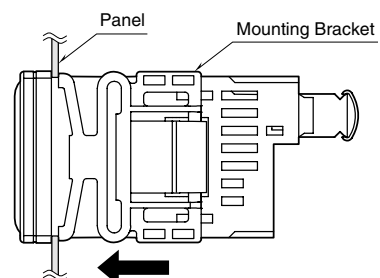

TERMINAL CONNECTIONS

Connect the unit as in the diagram below or refer to the connection diagram on the top of the unit.

EXTERNAL DIMENSIONS unit: mm (inch)

TOP VIEW

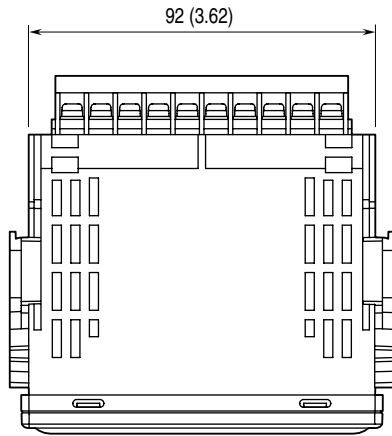

FRONT VIEW

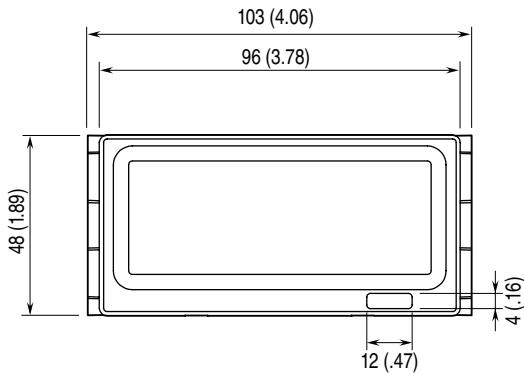

SIDE VIEW

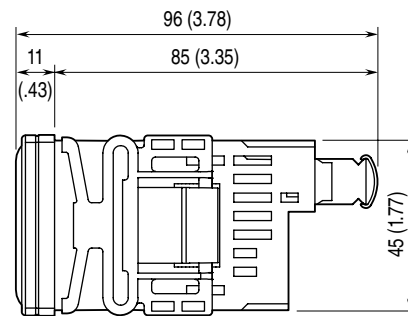

REAR VIEW

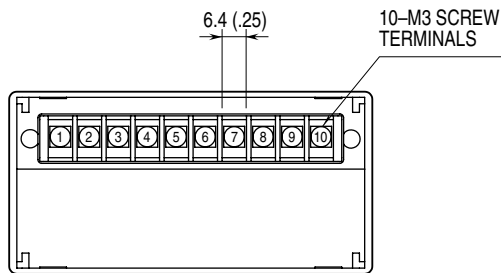

CONNECTION DIAGRAM

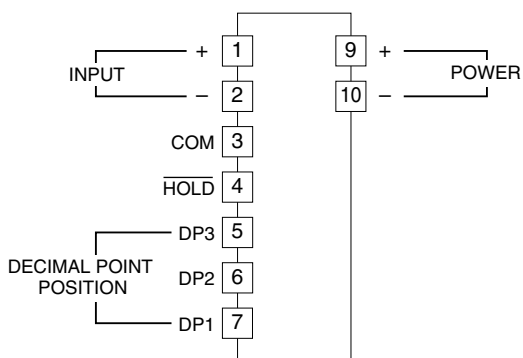

WIRING INSTRUCTIONS

SCREW TERMINAL

Torque: 0.6 N·m

SOLDERLESS TERMINAL

Refer to the drawing below for recommended ring tongue terminal size. Spade tongue type is also applicable.

Applicable wire size: 0.25 to 1.65 mm² (AWG 22 to 16)

Recommended manufacturer: Japan Solderless Terminal MFG.Co.Ltd, Nichifu Co.,Ltd

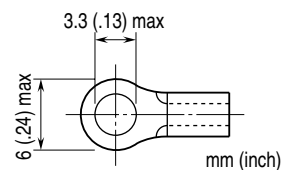

DECIMAL POINT POSITION

Close across the terminals as following.

Use a short-circuit bar or a short wire.

DP1 ($\times 10^1$) LED ON Terminal 7 to 3

DP2 ($\times 10^2$) LED ON Terminal 6 to 3

DP3 ($\times 10^3$) LED ON Terminal 5 to 3

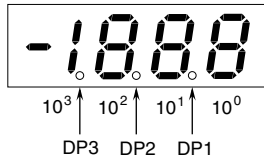

DISPLAY HOLD COMMAND

Connect the contacts across $\overline{\text{HOLD}}$ to COM.

(a) Photo-Coupler

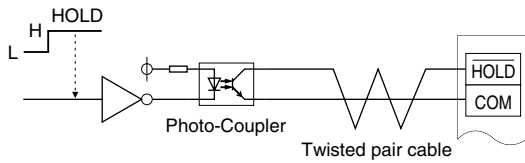

(b) Relay

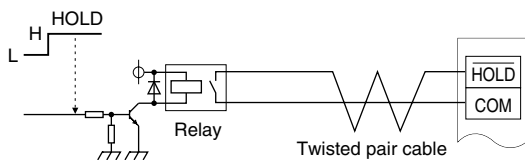

MAINTENANCE

Regular calibration procedure is explained below:

■ CALIBRATION

- 1) Turn on the power supply on the unit and keep on supplying the voltage for 10 minutes or more.
- 2) Remove the front panel.
- 3) Make a line between terminals 1 to 2 short-circuited and confirm that the display becomes "000."
- 4) Connect a signal generator to the unit, adjust the signal to the values in the following table and confirm the displays.

MODEL	SIGNAL VALUE	DISPLAY VALUE
40LV-V1-R	199.0 mV	1990
40LV-V2-R	1.990 V	1990
40LV-V3-R	19.90 V	1990
40LV-V4-R	199.0 V	1990
40LV-A1-R	199.0 μA	1990
40LV-A2-R	1.990 mA	1990
40LV-A3-R	19.90 mA	1990
40LV-A4-R	199.0 mA	1990
40LV-A5-R	1.990 A	1990

- 5) If the display value is different from the signal value, adjust it turning the span adjuster at "1990."
- 6) Mount the front panel to the unit again and confirm that the measurement accuracy is according to the range.

LIGHTNING SURGE PROTECTION

We offer a series of lightning surge protectors for protection against induced lightning surges. Please contact us to choose appropriate models.