

**BEFORE USE ....**

Thank you for choosing us. Before use, please check contents of the package you received as outlined below. If you have any problems or questions with the product, please contact our sales office or representatives.

**PACKAGE INCLUDES:**

- Signal conditioner .....(1)
- (Option) DIN rail mounting plate (model: A-31) .....(1 set)
- (Option) Spring clip (model: A-02).....(1 set)

**MODEL NO.**

Confirm Model No. marking on the product to be exactly what you ordered.

**INSTRUCTION MANUAL**

This manual describes necessary points of caution when you use this product, including installation, connection and basic maintenance procedures.

**POINTS OF CAUTION**

**GENERAL PRECAUTIONS**

- Before you remove the unit or mount it, turn off the power supply and input signal for safety.

**ENVIRONMENT**

- Indoor use.
- When heavy dust or metal particles are present in the air, install the unit inside proper housing with sufficient ventilation.
- Do not install the unit where it is subjected to continuous vibration. Do not subject the unit to physical impact.
- Environmental temperature must be within -5 to +70°C (23 to 158°F) with relative humidity within 30 to 90% RH in order to ensure adequate life span and operation.

**WIRING**

- Do not install cables close to noise sources (relay drive cable, high frequency line, etc.).
- Do not bind these cables together with those in which noises are present. Do not install them in the same duct.

**AND ....**

- The unit is designed to function as soon as power is supplied, however, a warm up for 10 minutes is required for satisfying complete performance described in the data sheet.

**COMPONENT IDENTIFICATION**

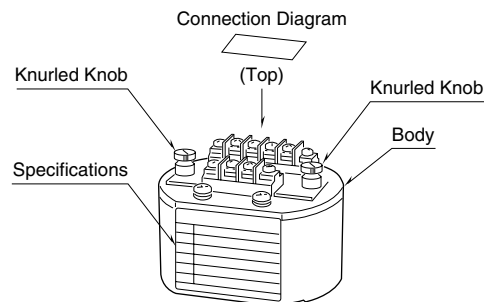

**INSTALLATION**

**35-mm DIN RAIL MOUNTING PLATE A-31 (optional) unit: mm (inch)**

- 1) Attach the unit to the DIN rail mounting plate with screws included in the package.
- 2) Set the plate so that its DIN rail adapter is at the bottom. Hang the upper hook at the rear side on the DIN rail and push in the lower. When removing the plate, push down the DIN rail adapter utilizing minus screwdriver and pull.

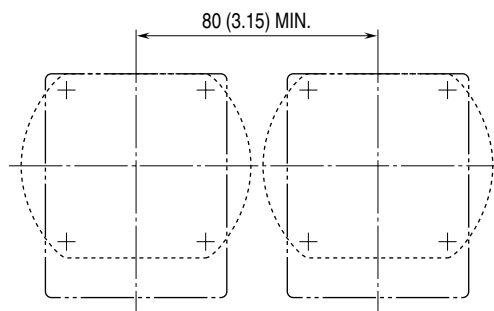

**SPRING CLIP A-02 (optional)**

- 1) Remove the two flat-head screws **A** located at the bottom as shown to the right.
- 2) Set Spring Clip **B** on the mounting hole and tighten it as shown to the right with a binding screw **C** included in the package.
- 3) Check that the clips contract and release smoothly.

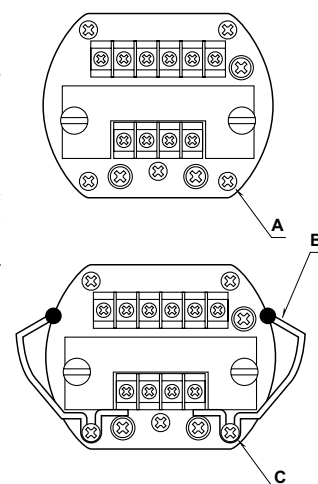

## TERMINAL CONNECTIONS

Connect the unit as in the diagram below or refer to the connection diagram on the top of the unit.

### EXTERNAL DIMENSIONS unit: mm (inch)

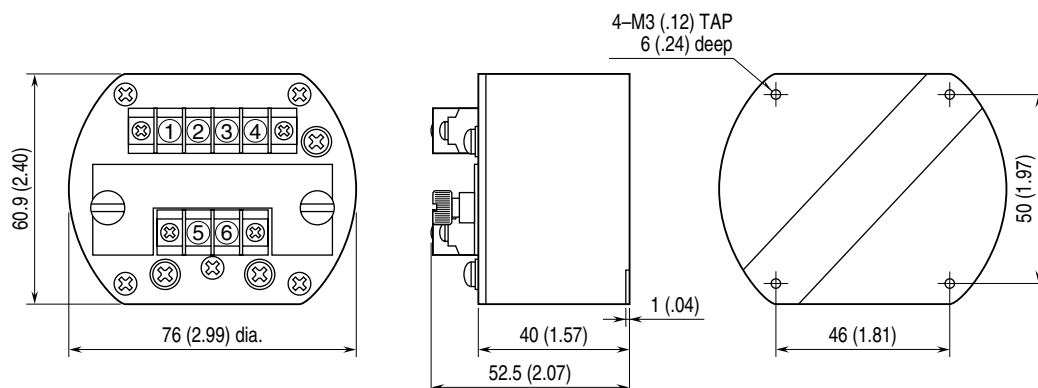

### CONNECTION DIAGRAM

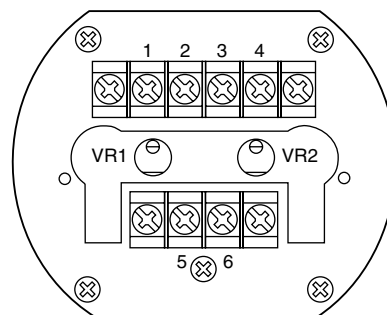
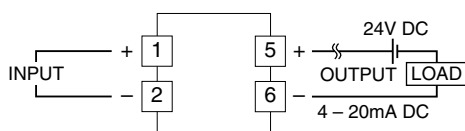

## WIRING INSTRUCTIONS

### SCREW TERMINAL

Torque: 0.6 N·m

## CHECKING

- 1) Terminal wiring: Check that all cables are correctly connected according to the connection diagram.
- 2) Input: Check current with an ammeter. Check that the input current is within 0 – 100% of the full-scale.
- 3) Supply voltage for differential pressure transmitter: Check that the voltage drop per loop during the use of this unit is no more than 5V. Be sure to supply adequate voltage using calculation based on the performance of the differential pressure transmitter and the load applied.

## ADJUSTMENT PROCEDURE

This unit is calibrated at the factory to meet the ordered specifications, therefore you usually do not need any calibration.

For matching the signal to a receiving instrument or in case of regular calibration, adjust the output as explained in the following. Zero and Span adjustments are located behind the top cover. Release the knurled knobs and open the cover.

### HOW TO CALIBRATE THE OUTPUT SIGNAL

Use a signal source and measuring instruments of sufficient accuracy level. Turn the power supply on and warm up for more than 10 minutes.

- 1) ZERO: Apply 1% input and adjust output to 10% with VR1.
- 2) SPAN: Apply 100% input and adjust output to 100% with VR2.
- 3) Check ZERO adjustment again with 1% input.
- 4) When ZERO value is changed, repeat the above procedure 1) – 3).

## MAINTENANCE

Regular calibration procedure is explained below:

### CALIBRATION

Warm up the unit for at least 10 minutes. Apply 0%, 4%, 16%, 36%, 64% and 100% input signal. Check that the output signal for the respective input signal is 0%, 20%, 40%, 60%, 80% and 100% in order, or remains within accuracy described in the data sheet. When the output is out of tolerance, recalibrate the unit according to the "ADJUSTMENT PROCEDURE" explained earlier.

## LIGHTNING SURGE PROTECTION

We offer a series of lightning surge protector for protection against induced lightning surges. Please contact us to choose appropriate models.