

**STRAIN GAUGE/DIGITAL CONVERTER**  
(16-bit resolution)

MODEL **AD2LC**

**BEFORE USE ....**

Thank you for choosing us. Before use, please check contents of the package you received as outlined below.

If you have any problems or questions with the product, please contact our sales office or representatives.

**PACKAGE INCLUDES:**

Signal conditioner (body + base socket).....(1)

**MODEL NO.**

Confirm Model No. marking on the product to be exactly what you ordered.

**INSTRUCTION MANUAL**

This manual describes necessary points of caution when you use this product, installation, connection and basic maintenance procedures.

**POINTS OF CAUTION**

**CONFORMITY WITH EU DIRECTIVES**

- This equipment is suitable for Pollution Degree 2 and Installation Category II (transient voltage 2500V). Basic insulation (signal input to output: 300V) is maintained. Prior to installation, check that the insulation class of this unit satisfies the system requirements.
  - Altitude up to 2000 meters.
  - The equipment must be mounted inside a panel.
  - Insert a noise filter for the power source connected to the unit. TDK-Lambda Noise Filter Model RSNA-2006 or equivalent is recommended.
  - The equipment must be installed such that appropriate clearance and creepage distances are maintained to conform to CE requirements. Failure to observe these requirements may invalidate the CE conformance.
  - The actual installation environments such as panel configurations, connected devices, connected wires, may affect the protection level of this unit when it is integrated in a panel system. The user may have to review the CE requirements in regard to the whole system and employ additional protective measures\* to ensure the CE conformity.
- \* For example, installation of noise filters and clamp filters for the power source, input and output connected to the unit, etc.
- Install lightning surge protectors for those wires connected to remote locations.

**POWER INPUT RATING & OPERATIONAL RANGE**

- Locate the power input rating marked on the product and confirm its operational range as indicated below:  
 100 – 240V AC rating: 85 – 264V, 47 – 66 Hz, approx. 10VA  
 24V DC rating: 24V ±10%, approx. 7W  
 110V DC rating: 85 – 150V, approx. 7W

**GENERAL PRECAUTIONS**

- Before you remove the unit from its base socket or mount it, turn off the power supply and input signal for safety.

**ENVIRONMENT**

- Indoor use.
- When heavy dust or metal particles are present in the air, install the unit inside proper housing and ventilate it.
- Do not install the unit where it is subjected to continuous

vibration. Do not subject the unit to physical impact.

- Environmental temperature must be within -5 to +55°C (23 to 131°F) with relative humidity within 30 to 90% RH in order to ensure adequate life span and operation.

**WIRING**

- Do not install cables close to noise sources (relay drive cable, high frequency line, etc.).
- Do not bind these cables together with those in which noises are present. Do not install them in the same duct.

**EXCITATION**

- Be sure to use the excitation of the unit.
- Adjust excitation voltage so that the current is below the maximum current of the excitation.

**RESPONSE TIME**

- Update period is less than or equal to 0.3 seconds. The update pauses by auto compensation for approx. 0.8 seconds at every 5 or 6 seconds. Response time should include that time.

**AND ....**

- The unit is designed to function as soon as power is supplied, however, a warm up for 10 minutes is required for satisfying complete performance described in the data sheet.

**COMPONENT IDENTIFICATION**

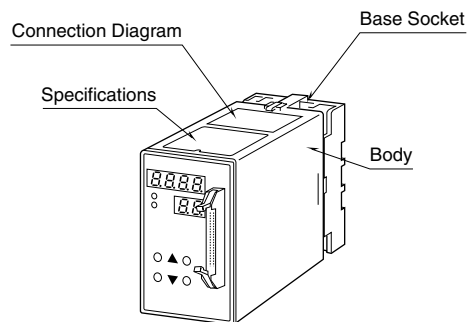

**INSTALLATION**

Detach the yellow clamps located at the top and bottom of the unit for separate the body from the base socket.

**DIN RAIL MOUNTING**

Set the base socket so that its DIN rail adaptor is at the bottom. Hang the upper hook at the rear side of base socket on the DIN rail and push in the lower. When removing the socket, push down the DIN rail adaptor utilizing a minus screwdriver and pull.

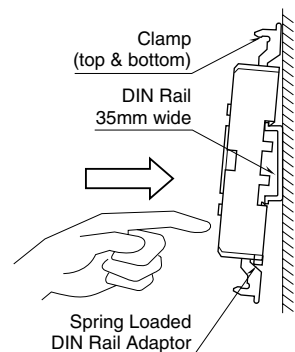

**WALL MOUNTING**

Refer to "EXTERNAL DIMENSIONS."

Shape and size of the base socket are slightly different with various socket types.

## FRONT PANEL CONFIGURATION & PROGRAMMING

### PROGRAMMING PROCEDURE

- 1) Press ITEM UP or DOWN key until ITEM display indicates "01".
- 2) Press DATA UP or DOWN key and choose "2" on DATA display.
  - 1 : Data indication only.
  - 2 : All parameters are modifiable.
- 3) Press ITEM UP or DOWN key until ITEM display shows the ITEM No. you need to change.
- 4) Press DATA UP or DOWN key and choose a DATA No. or value you need on DATA display.
- 5) Repeat above 3 and 4. (Entered data is stored when you move to a new ITEM.)
- 6) Press ITEM UP or DOWN key until ITEM display indicates "01".
- 7) Press DATA UP or DOWN key and choose "1" on the display.
- 8) Press ITEM UP or DOWN key until ITEM display indicates "P".
 

DATA display shows process input. You can now check data setting by choosing ITEM No.

Note : DO NOT press UP and DOWN keys simultaneously.

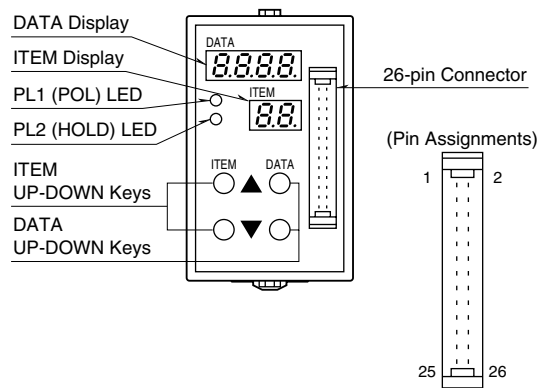

ITEM	MDF. CODE	DATA	CONTENTS	DEFAULT
P	N/A	-9999 – 9999 (-FFFF – FFFF)	Output display in engineering unit, BCD (as set in ITEM 17/18) ( ) for binary, offset binary, two's complement, reflected binary	----
01		1, 2	Modification code 1 : Data indication only. 2 : All parameters are modifiable.	1
02	N/A	0 – 99	Status indication ("0" is normally indicated.)	----
03	N/A	0, 1, 2	Input range code 0 : S1 (0.0 – 3.0mV/V) 1 : S2 (0.0 – 10.0mV/V) 2 : S3 (0.0 – 30.0mV/V)	User specified
04	2	0.1 – 12.0	Excitation voltage (V)	1.0V
05	2	0.010 – 3.000 0.010 – 9.999 0.10 – 30.0	Sensor sensitivity S1 : 0.0 – 3.0mV/V S2 : 0.0 – 10.0mV/V S3 : 0.0 – 30.0mV/V Used when adjusting the sensor sensitivity by its rating value. Set ITEM 06 before 05.	3.000 9.999 30.00
06	2	-30.00 – 30.00 -99.99 – 99.99 -300.0 – 300.0	0% input voltage S1 : -30.00 – 30.00mV S2 : -99.99 – 99.99mV S3 : -300.0 – 300.0mV Sensor's zero adjustment. Approximate offset voltage.	
07	2	-30.00 – 30.00 -99.99 – 99.99 -300.0 – 300.0	100% input voltage S1 : -30.00 – 30.00mV S2 : -99.99 – 99.99mV S3 : -300.0 – 300.0mV Used when adjusting the sensor sensitivity with an actual load. Set ITEM 06 before 07.	
08	2	10.0 – 100.0	Load ratio (%) Used when adjusting the sensor sensitivity with an actual load.	100.0
09	2	-999.9 – 999.9	Tare adjustment (%)	0.0
10	N/A	-15.0 – 115.0	Input indicated in % (of the range set in ITEM 05/06/07)	----
11	2	-99.99 – 99.99	Zero adjustment (%) (fine adj. of the value set in ITEM 05/06/07)	0.00
12	2	0.000 – 9.999	Gain adjustment (fine adj. of the value set in ITEM 05/06/07)	1.000
13	2	0, 1, 2, 3, 4	Moving average (200 msec./sampling) 0: No 1: 4 samples 2: 8 samples 3: 16 samples 4: 32 samples	0
14	2	0, 1, 2, 3	Contact input function 0 : Tare adjustment 1 : Peak hold 2 : Valley hold 3 : Sample hold	0
15	2	10 – 99	Power ON-delay time (seconds)	10
16	2	0, 1 – 60	Power-saving mode 0 : Continuous display 1 – 60 : Time before display turned off (minutes)	10
17	2	-9999 – 9999	BCD Display range scaling 0% *1	-1000
18	2	-9999 – 9999	Display range scaling 100% *1	1000
17	2	-7FFF – 7FFF	Binary Display range scaling 0% *1	-7FFF
18	2	-7FFF – 7FFF	Display range scaling 100% *1	7FFF

ITEM	MDF. CODE	DATA	CONTENTS		DEFAULT
17	2	0000 – FFFF	Offset binary	Display range scaling 0% *1	0000
18	2	0000 – FFFF		Display range scaling 100% *1	FFFF
17	2	8000 – 7FFF	Two's complement	Display range scaling 0% *1	8000
18	2	8000 – 7FFF		Display range scaling 100% *1	7FFF
17	2	0000 – FFFF	Reflected binary	Display range scaling 0% *1	0000
18	2	0000 – FFFF		Display range scaling 100% *1	FFFF
19	2	0, 1, 2, 3, 4	Display code 1 : Binary with polarity 3 : Two's complement	0 : BCD with polarity (decimal) 2 : Offset binary 4 : Reflected binary	0
20	2	0, 1, 2, 3, 4	Available number of bits 0: 16 bits 1: 14 bits 2: 12 bits 3: 10 bits 4: 8 bits		0
21	2	0, 1	POL, OVF output logic	0 : Data available at High (CMOS level) or ON (open collector) 1 : Data available at Low (CMOS level) or OFF (open collector)	0
22	2	0, 1	Data output logic *2	0 : Positive (CMOS level, Negative (open collector) 1 : Negative (CMOS level, Positive (open collector)	0
23	2	0, 1	HOLD input logic	0 : HOLD at Low or shortcircuit 1 : HOLD at High or opencircuit	0
24	2	0, 1	DAV output logic	0 : Data available at High (CMOS level) or ON (open collector) 1 : Data available at Low (CMOS level) or OFF (open collector)	0
25	2	1 – 50	DAV output time (msec.)		1
26	N/A	----	ROM version		----

\*1. Of the range set in ITEM 05/06/07. ITEM 17 < ITEM 18.

\*2. ITEM 21, 23 or 24 is independent from ITEM 22.

## ■ SENSOR ADJUSTMENTS USING AN ACTUAL LOAD

### 1. Program Mode

Set ITEM 01 – DATA 2 to turn the unit into Program Mode.

### 2. Excitation Voltage

Choose ITEM 04. Press DATA UP or DOWN key until the DATA display shows the desired excitation voltage. When the value calculated by [Excitation / Resistance] exceeds 30 mA, set a voltage value to fit with 30 mA limit.

[E.G. 1] Max. excitation voltage 10 V  
Strain gauge resistance 120 Ω

If you choose 10V as the excitation:

$$10 \text{ V} / 120 \text{ } \Omega = 83.3 \text{ mA} \text{ ----> out of allowable range}$$

Then you will choose 3.6 V or less as calculated by the equation below:

$$30 \text{ mA} \times 120 \text{ } \Omega = 3.6 \text{ V}$$

### 3.0% Input Voltage

Choose ITEM 06. With no load applied to the sensor, press DATA DOWN key until the display value is stabilized (while the computation circuit of the unit conducts averaging process).

DATA display shows the approximate offset voltage.

$$\text{Display Value} = \text{Sensor Voltage} \times \text{Internal Coefficient}^*$$

### 4. 100% Input Voltage

Choose ITEM 07. With an actual known load, press DATA DOWN key until the display value is stabilized (while the computation circuit of the unit conducts averaging process).

DATA display shows the sensor's sensitivity span.

### 5. Monitor Mode

Set ITEM 01 – DATA 1 to turn the unit into Monitor Mode.

### 6. PV Indication

Press ITEM UP or DOWN key until ITEM display indicates "P".

If necessary, go to Display Range Scaling, Moving Average, and other adjustments.

Set the unit to Monitor Mode with ITEM P displayed other than for programming.

\* If 100% load is not available, use the load ratio setting.

With 10% load, set ITEM 08 – DATA 10.0 before adjustments.

## ■ SENSOR ADJUSTMENTS BY ENTERING VALUES

### 1. Turn the unit into Program Mode.

### 2. Excitation Voltage

Choose ITEM 04. Press DATA UP or DOWN key until the DATA display shows the desired excitation voltage. When the value calculated by [Excitation / Resistance] exceeds 30 mA, set a voltage value to fit with 30 mA limit.

[E.G. 1] Max. excitation voltage 10 V  
Strain gauge resistance 120 Ω

If you choose 10 V as the excitation:

$$10 \text{ V} / 120 \text{ } \Omega = 83.3 \text{ mA} \text{ ----> out of allowable range}$$

Then you will choose 3.6 V or less as calculated by the equation below:

$$30 \text{ mA} \times 120 \text{ } \Omega = 3.6 \text{ V}$$

### 3.0% Input Voltage

Choose ITEM 06. With no load applied to the sensor, press DATA DOWN key until the display value is stabilized (while the computation circuit of the unit conducts averaging process).

DATA display shows the approximate offset voltage.

$$\text{Display Value} = \text{Sensor Voltage} \times \text{Internal Coefficient}$$

### 4. Sensor's Sensitivity

Choose ITEM 05. Press DATA UP or DOWN key until the display shows desired value as specified in the sensor's specification sheet.

### 5. Turn the unit into Monitor Mode.

### 6. Set to ITEM P.

If necessary, go to Display Range Scaling, Moving Average, and other adjustments.

Set the unit to Monitor Mode with ITEM P displayed other than for programming.

**■ TARE ADJUSTMENT**

1. Turn the unit into Program Mode.

2. Contact Input Function

Choose ITEM 14 – DATA 0.

3. Turn the unit into Monitor Mode.

(ITEM 14 is set to DATA 0 as default. No need of conducting 1 through 3.)

4. Set to ITEM P.

5. Close across the contact input terminals (Di).

By the abovementioned procedure, the tare value is stored in ITEM 09, the PV display shows the value set by 0% Scaling Value, and the transmitter outputs the value set by 0% Output.

The abovementioned procedure is applicable to modifications from default setting.

**TERMINAL CONNECTIONS**

Connect the unit as in the diagram below or refer to the connection diagram on the top of the unit.

**■ EXTERNAL DIMENSIONS unit: mm (inch)**

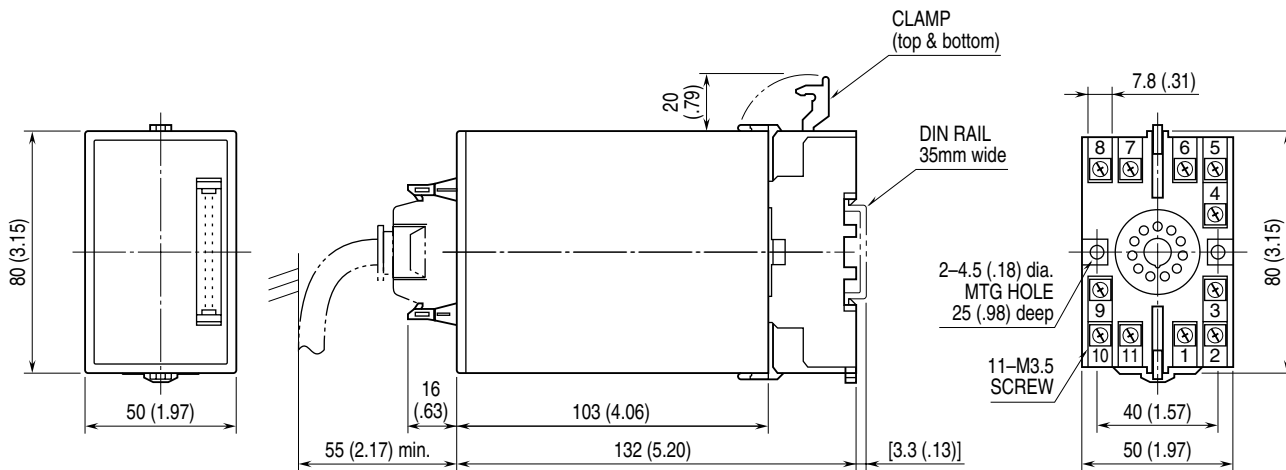

•When mounting, no extra space is needed between units.

**■ CONNECTION DIAGRAM**

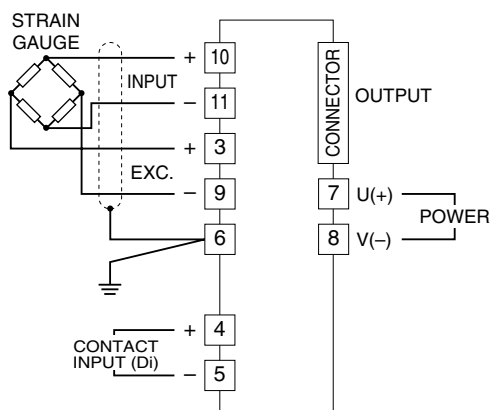

## CONNECTION EXAMPLES

### • CMOS LEVEL (5V-CMOS)

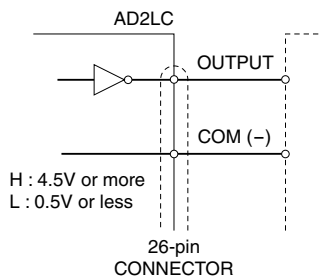

### • OPEN COLLECTOR

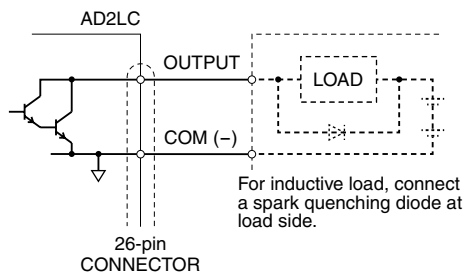

Max. collector-emitter voltage : 30V DC  
Max. collector current : 30mA  
Saturation voltage :  $\leq 1.1V$  DC

## OUTPUT CONNECTOR (26-pin)

### ■ BCD OUTPUT

PIN NO.	ASSIGNMENT	PIN NO.	ASSIGNMENT
1	$1 \times 10^0$	17	COM
2	$2 \times 10^0$	18	COM
3	$4 \times 10^0$	19	OVF
4	$8 \times 10^0$	20	POL
5	$1 \times 10^1$	21	DAV
6	$2 \times 10^1$	22	$\overline{\text{HOLD}}^{*1}$
7	$4 \times 10^1$	23	COM
8	$8 \times 10^1$	24	COM
9	$1 \times 10^2$	25	No connection
10	$2 \times 10^2$	26	No connection
11	$4 \times 10^2$		
12	$8 \times 10^2$		
13	$1 \times 10^3$		
14	$2 \times 10^3$		
15	$4 \times 10^3$		
16	$8 \times 10^3$		

### ■ BINARY, TWO'S COMPLEMENT OUTPUTS

PIN NO.	ASSIGNMENT	PIN NO.	ASSIGNMENT
1	B <sup>0</sup>	17	COM
2	B <sup>1</sup>	18	COM
3	B <sup>2</sup>	19	OVF
4	B <sup>3</sup>	20	POL
5	B <sup>4</sup>	21	DAV
6	B <sup>5</sup>	22	$\overline{\text{HOLD}}^{*1}$
7	B <sup>6</sup>	23	COM
8	B <sup>7</sup>	24	COM
9	B <sup>8</sup>	25	No connection
10	B <sup>9</sup>	26	No connection
11	B <sup>10</sup>		
12	B <sup>11</sup>		
13	B <sup>12</sup>		
14	B <sup>13</sup>		
15	B <sup>14</sup>		
16	B <sup>15</sup>		

\*1.  $\overline{\text{HOLD}}$  signal is for input, the others are for output.

Note: With the number of bits set to 14 (or 12, 10, 8) with ITEM 20, Pin No. 1 – 14 (or 1 – 12, 1 – 10, 1 – 8) are valid.

# CABLE (MODEL: MCN26) PIN ASSIGNMENTS

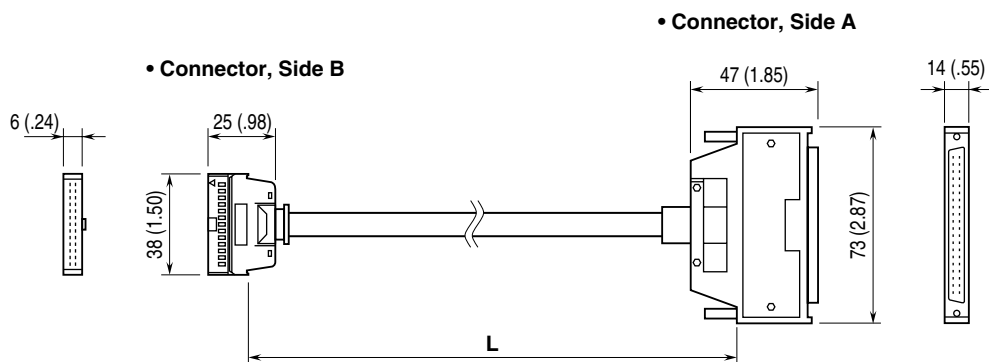

	MCN26-03	MCN26-05	MCN26-10	MCN26-30
<b>L</b>	30 cm (11.8 in.)	50 cm (19.7 in.)	1 m (3.3 ft.)	3 m (9.8 ft.)

## CONNECTOR PIN ASSIGNMENT

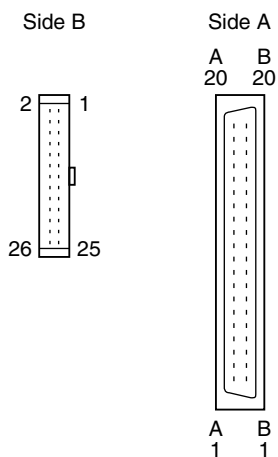

## WIRING DIAGRAM

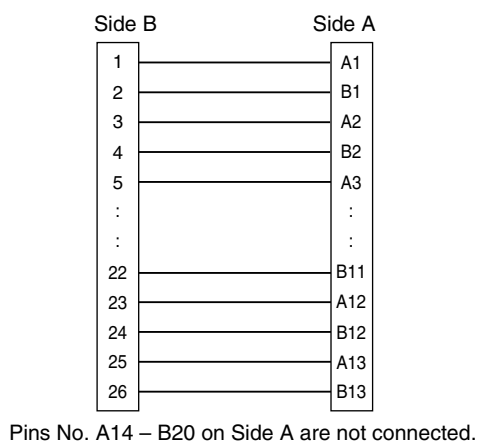

## TIMING CHART

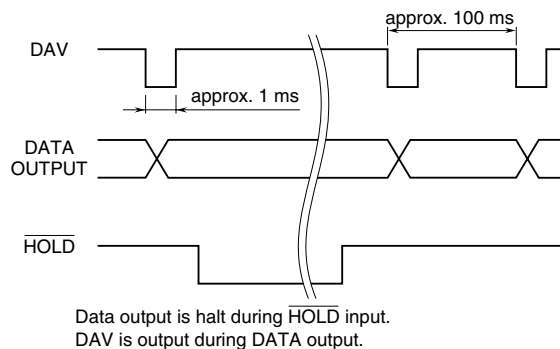

## INPUT-OUTPUT RELATIONSHIP EXAMPLES

### ■ BCD, BINARY (WITH POLARITY)

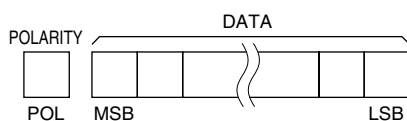

### ■ OFFSET BINARY & TWO'S COMPLEMENT

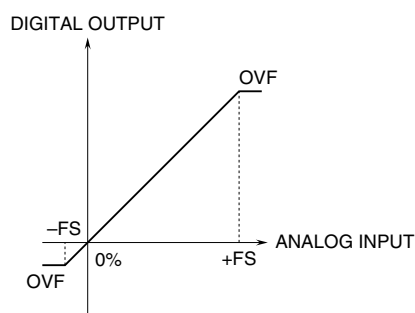
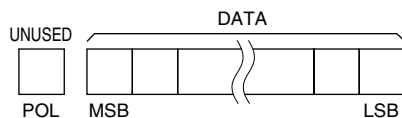

#### • FS

-FS stands for 0 % of the input range configured by ITEM 06. +FS stands for +100 % of the input range, configured by ITEM 07.

#### • OVF

When one of the following conditions is true, the digital output overflows (OVF).

- 1) When the input signal is out of the range between -FS and +FS.
- 2) When the display value (= output signal) exceeds the display range.

The display range differs according to output code. For example, in case of BCD with polarity, it is -9999 to 9999. Please refer to the table in the FRONT PANEL CONFIGURATION & PROGRAMMING for detail.

---

## CHECKING

- 1) Terminal wiring: Check that all cables are correctly connected according to the connection diagram.
- 2) Power input voltage: Check voltage across the terminal 7 – 8 with a multimeter.
- 3) Strain gauge: Maximum allowable current supplied to the strain gauge is 30 mA. Check the resistance of the sensor.
- 4) Input: Check voltage across the terminal 10 (+) – 11 (–) with a multimeter. The voltage value at the maximum load must equal [Excitation × Strain Gauge Sensitivity].
- 5) Output
  - Open collector: Check that the output load is 30 V DC/30 mA at the maximum. Saturation voltage is 1.1 V DC. Check the input threshold voltage (at L level) of the connected device to be greater than that.
  - CMOS level: Check the output voltage ( $H \geq 4.5 \text{ V DC}$ ,  $L \leq 0.5 \text{ V DC}$ ).

---

## LIGHTNING SURGE PROTECTION

We offer a series of lightning surge protector for protection against induced lightning surges. Please contact us to choose appropriate models.