

POTENTIOMETER ALARM

(dual or quad alarm trip; field-configurable)

MODEL

AS4M

BEFORE USE

Thank you for choosing us. Before use, please check contents of the package you received as outlined below.

If you have any problems or questions with the product, please contact our sales office or representatives.

This equipment is for use in general industrial environments, therefore may not be suitable for applications which require higher level of safety (e.g. safety or accident prevention systems) or of reliability (e.g. vehicle control or combustion control systems).

For safety, installation and maintenance of this equipment must be conducted by qualified personnel.

■ PACKAGE INCLUDES:

Potentiometer alarm (body + base socket).....(1)

■ MODEL NO.

Confirm Model No. marking on the product to be exactly what you ordered.

■ INSTRUCTION MANUAL

This manual describes necessary points of caution when you use this product, including installation, connection and basic maintenance procedures.

■ SYMBOLS USED ON THE PRODUCT AND IN THIS MANUAL

 The symbol indicated on the equipment, means that the user must refer to the related parts in the manual for safe operation of the equipment. It is essential to read the instructions wherever the symbol appears in the manual.

 **WARNING:** is reserved for conditions and actions that can cause serious or fatal injury.

 **CAUTION:** is reserved for conditions and actions that can cause injury or instrument damage.

WARNING

■ INSULATION CLASS

Basic insulation (Signal input or output to Power input: 300V) is maintained.

If insulation failure may result in equipment, hazardous voltage (maximum 240V) may result to signal input and then electric shock may cause.

Prior to installation, prepare supplemental insulation (equivalent basic insulation) between signal input and external circuits.

CAUTION

■ REGARDING SAFETY

If the equipment is used in a manner not specified by this manual, the protection provided by the equipment may be impaired.

■ CONFORMITY WITH LOW VOLTAGE DIRECTIVE OR UL

- This equipment is suitable for Pollution Degree 2, Measurement Category II (output, transient voltage 2500V) and Installation Category II (transient voltage 2500V).
- Altitude up to 2000 meters.
- The equipment must be mounted inside a panel.
- The equipment must be installed such that appropriate clearance and creepage distances are maintained to conform to EU/UL requirements. Failure to observe these requirements may invalidate the EU/UL conformance.

■ CONFORMITY WITH EMC DIRECTIVE

- Insert a noise filter for the power source connected to the unit. TDK-Lambda Noise Filter Model RSNA-2006 or equivalent is recommended.
 - The actual installation environments such as panel configurations, connected devices, connected wires, may affect the protection level of this unit when it is integrated in a panel system. The user may have to review the CE requirements in regard to the whole system and employ additional protective measures* to ensure the CE conformity.
- * For example, installation of noise filters and clamp filters for the power source, input and output connected to the unit, etc.

■ SIGNAL INPUT

This terminal is used for signal input.

Do not connect or measure to the circuits including transient voltage 2500V.

Refer to "INPUT SPECIFICATIONS" in detail.

■ OUTPUT TERMINAL

Never use the output terminal under any load that exceeds the rated values. Otherwise it will impair prescribed performance and cause burning of the equipment itself.

■ WIRING

- For wiring connection, refer to "TERMINAL CONNECTIONS" and wire correctly. Fire, electric shock and failure cause if wire are incorrectly connected.
- Wire using vinyl insulated power cable that meet input voltage and load current for equipment and screw by an adequate torque.
Loose screws may abnormally generate heat and fire may cause. (Proper tightening torque [N·m] : 0.98 – 1.18)
- Do not install cables close to noise sources (relay drive cable, high frequency line, etc.).
- Do not bind these cables together with those in which noises are present. Do not install them in the same duct.

POINTS OF CAUTION

■ POWER INPUT RATING & OPERATIONAL RANGE

- Locate the power input rating marked on the product and confirm its operational range as indicated below:

■ AC Power

M2: 100 – 240 V AC, 50 – 60 Hz, maximum 6 VA
(85 – 264 V AC, 47 – 66 Hz)

■ DC Power

R: 24 V DC (24 V \pm 10%), maximum 3.5 W
P: 110 V DC (85 – 150 V), maximum 3.5 W

■ GENERAL PRECAUTIONS

- Before you remove the unit from its base socket or mount it, turn off the power supply and input signal for safety.

■ ENVIRONMENT

- Indoor use.
- When heavy dust or metal particles are present in the air, install the unit inside proper housing with sufficient ventilation.
- Do not install the unit where it is subjected to continuous vibration. Do not subject the unit to physical impact.
- Environmental temperature must be within -5 to +55°C (23 to 131°F) with relative humidity within 30 to 90% RH in order to ensure adequate life span and operation.

■ AND

- The unit is designed to function as soon as power is supplied, however, a warm up for 10 minutes is required for satisfying complete performance described in the data sheet.
- Never use the internal relay under any load that exceeds the rated contact values including the switching capacities (contact voltage and contact current). Otherwise it will impair prescribed performance (insulation failure, contact welding, contact failure) and cause burning of the Relay itself.

COMPONENT IDENTIFICATION

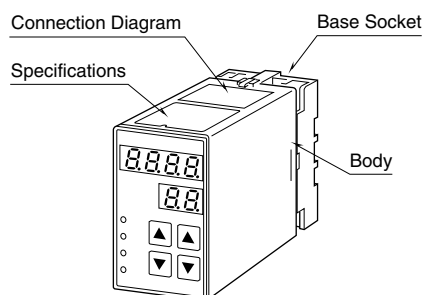

INPUT SPECIFICATIONS

Minimum span : 10% of total resistance

Excitation : 0.5 V DC

OUTPUT SPECIFICATIONS

■ Quad Alarm

Relay rating: 120 V AC @ 1 A ($\cos \phi = 1$)
240 V AC @ 0.5 A ($\cos \phi = 1$)
30 V DC @ 1 A (resistive load)

■ Dual Alarm

Relay rating: 120 V AC @ 5 A ($\cos \phi = 1$)
240 V AC @ 2.5 A ($\cos \phi = 1$)
30 V DC @ 5 A (resistive load)

INSTALLATION

Detach the yellow clamps located at the top and bottom of the unit for separate the body from the base socket.

■ DIN RAIL MOUNTING

Set the base socket so that its DIN rail adaptor is at the bottom. Position the upper hook on the DIN rail and push in the lower. When removing the socket, push down the DIN rail adaptor utilizing a minus screwdriver and pull.

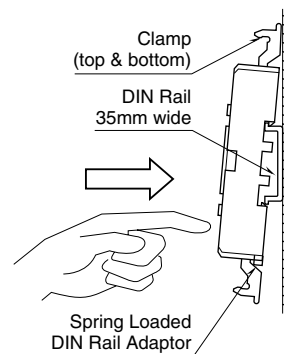

Shape and size of the base socket are slightly different with various socket types.

■ WALL MOUNTING

- Install using M4 screw with referring to the right dimension.
- Install by screw that is securely fastened or equivalent means.

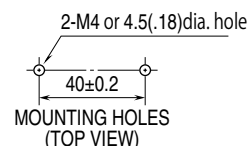

FRONT VIEW & PROGRAMMING

PROGRAMMING PROCEDURE

- 1) Press ITEM UP or DOWN key until ITEM display indicates "01".
- 2) Press DATA UP or DOWN key and choose "1" or "2" on DATA display.
 - 1: Only alarm setpoints are modifiable.
 - 2: All parameters are modifiable.
- 3) Press ITEM UP or DOWN key until ITEM display shows the ITEM No. you need to change.
- 4) Press DATA UP or DOWN key and choose a DATA No. or value you need on DATA display.
- 5) Repeat above 3 and 4. (Entered data is stored when you move to a new ITEM.)
- 6) Press ITEM UP or DOWN key until ITEM display indicates "01".
- 7) Press DATA UP or DOWN key and choose "0" on the display.
- 8) Press ITEM UP or DOWN key until ITEM display indicates "P".
DATA display shows process input.

(You can now check data setting by choosing ITEM No.)

Note: DO NOT press UP and DOWN keys simultaneously.

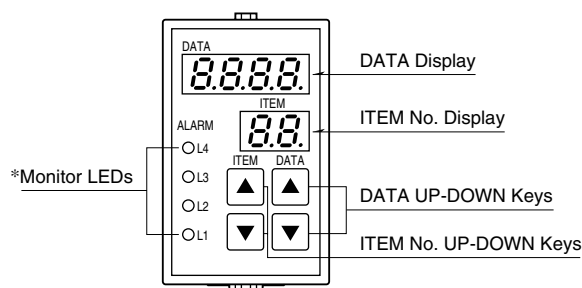

*L3 or L4 does not turn on for dual output type.

ITEM	MDF. CODE	DATA	CONTENTS	DEFAULT SETTING
P	N/A	-1999 – 9999	Process input display in engineering unit (as set in ITEM 07, 08)	----
L1	1, 2	-1999 – 9999*1	L1 alarm setpoint in engineering unit	Quad: 20.0 Dual: 20.0
L2	1, 2	-1999 – 9999*1	L2 alarm setpoint in engineering unit	Quad: 30.0 Dual: 80.0
L3	1, 2	-1999 – 9999*1	L3 alarm setpoint in engineering unit *2	Quad: 70.0
L4	1, 2	-1999 – 9999*1	L4 alarm setpoint in engineering unit *2	Quad: 80.0
01		0, 1, 2	Modification code 0: Data indication only. 1: Only ITEM L1 – L4 are modifiable. 2: All parameters are modifiable.	1
02	N/A	0	Status indication ("0" is normally indicated.) 0: Normal 1: Memory error 10: Out of input range -15 – +115%	
03	N/A	5	Input type 5: Potentiometer	
04	N/A	-15.0 – 115.0	Input indicated in % (as set in ITEM 27, 28)	----
05	2	-19.99 – 99.99	Zero adjustment (%) (fine adj. of the value set in ITEM 27)	0.00
06	2	0.000 – 9.999	Gain adjustment (fine adj. of the value set in ITEM 28)	1.000
07	2	-1999 – 9999	Display range scaling 0% *3	0.0
08	2	-1999 – 9999	Display range scaling 100% *3	100.0
09	2	0, 1, 2, 3	Decimal point position 0: ____ (Specify the number of 1: ____. digits) 2: ____. 3: ____.	1
10	2	0 – 99	Power ON-delay time (seconds)	5
11	2	0 – 999	Alarm ON-delay time (seconds)	0
12	2	0, 1, 2, 3, 4	Moving average (sampling cycle: 100 msec.) 0: No, 1: 4 samples, 2: 8 samples, 3: 16 samples, 4: 32 samples	0
13	2	0, 1	L1 trip operation (0: Lo, 1: Hi)	Quad: 0 Dual: 0
14	2	0, 1	L2 trip operation (0: Lo, 1: Hi)	Quad: 0 Dual: 1
15	2	0, 1	L3 trip operation (0: Lo, 1: Hi) *2	Quad: 1
16	2	0, 1	L4 trip operation (0: Lo, 1: Hi) *2	Quad: 1
17	2	-1, 0, 1 – 60	Power-saving mode -1: Continuous display upon startup 0: Continuous display after the last access 1 – 60: Time before display turned off (minutes)	0: Continuous display
18	2	0, 1	L1 coil at alarm (0: Energized, 1: De-energized)	0
19	2	0, 1	L2 coil at alarm (0: Energized, 1: De-energized)	0
20	2	0, 1	L3 coil at alarm (0: Energized, 1: De-energized)*2	0
21	2	0, 1	L4 coil at alarm (0: Energized, 1: De-energized)*2	0
22	N/A	----	Version No. indication	----
23	2	1 – 9999	L1 hysteresis (deadband) in engineering unit	1.0
24	2	1 – 9999	L2 hysteresis (deadband) in engineering unit	1.0
25	2	1 – 9999	L3 hysteresis (deadband) in engineering unit *2	1.0
26	2	1 – 9999	L4 hysteresis (deadband) in engineering unit *2	1.0

ITEM	MDF. CODE	DATA	CONTENTS	DEFAULT SETTING
27	2	0.0 – 100.0	0% input (%) (ITEM 27 < ITEM 28)	0.0
28	2	0.0 – 100.0	100% input (%) (ITEM 27 < ITEM 28)	100.0
29	2	0, 1	Latching control (0: Disabled, 1: Enabled) Selecting "0" resets latching relays. Turning power supply off also resets them.	0
30	----	0000 – 1111	Alarm indication (0: OFF, 1: ON) The MSD indicates the L1, while the LSD indicates the L4.	----

*1. Selectable within the display scaling range

*2. Quad alarm trip type only

*3. Of the range set in ITEM 05, 06. ITEM 07 < ITEM 08.

TERMINAL CONNECTIONS

Connect the unit as in the diagram below or refer to the connection diagram on the top of the unit.

EXTERNAL DIMENSIONS unit: mm (inch)

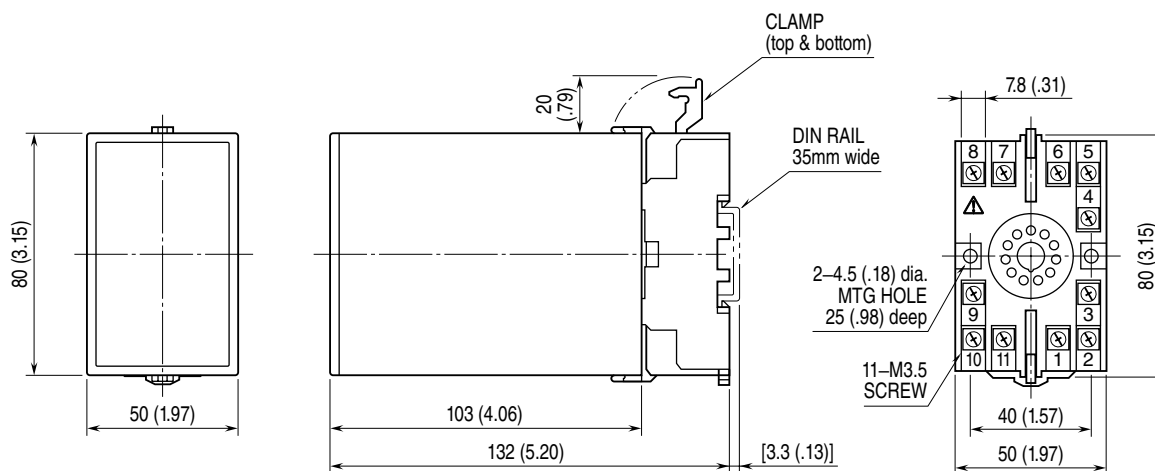

• When mounting, no extra space is needed between units.

⚠ For wiring connection, refer to "TERMINAL CONNECTIONS" and wire correctly.
Fire, electric shock and failure cause if wire are incorrectly connected.

CONNECTION DIAGRAM

N.O. RELAY

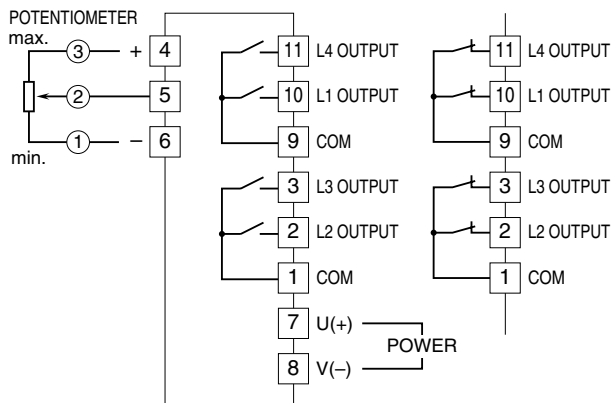

N.C. RELAY

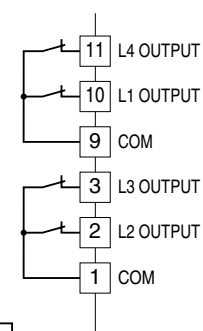

SPDT RELAY

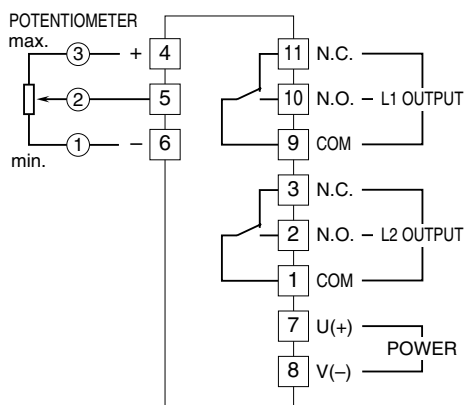

CHECKING

- 1) Terminal wiring: Check that all cables are correctly connected according to the connection diagram.
- 2) Power input voltage: Check voltage across the terminal 7 – 8 with a multimeter.
- 3) Input: Check voltage across the terminal 5 (+) – 6 (–) with a voltmeter to show 0V at 0% potentiometer input and the same voltage as that across 4 (+) – 6 (–) at 100% input.
- 4) Alarm operations: Check the alarm operations referring to the figure below.
- 5) Output load: Check that the output rating road is: 240 V AC / 120 VA or 30 V DC / 30 W (240 V AC / 600 VA or 30 V DC / 150 W for dual alarm, Output Code 5) at the maximum. For maximum relay life with inductive load, external protection is recommended.

Alarm Trip Operation

Terminal No. in parentheses

Example with quad N.O. contacts (LL, L, H, HH)

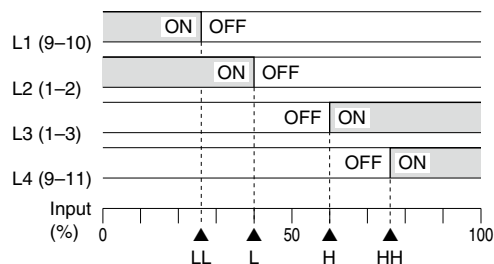

Trip Operation in Power Failure

- Output code 2: All relays turn off.
- Output code 3: All relays turn on.
- Output code 5: Terminals 1 – 3, 9 – 11 turn on.

MAINTENANCE

Regular calibration procedure is explained below:

CALIBRATION

Warm up the unit for at least 10 minutes.

H (HH) Setpoint

Increase the input signal from a value lower than the setpoint and check that the relay trips at the H (or HH) setpoint within the setpoint accuracy described in the data sheet.

L (LL) Setpoint

Decrease the input signal from a value higher than the setpoint and check that the relay trips at the L (or LL) setpoint within the setpoint accuracy described in the data sheet.

When the setpoints are shifted, please contact our sales office or representatives.

LIGHTNING SURGE PROTECTION

We offer a series of lightning surge protector for protection against induced lightning surges. Please contact us to choose appropriate models.