

STANDARD RACK MOUNTING FRAME
(with power distributor, single-pole fuse)

MODEL **BX-16G-2**

BEFORE USE

Thank you for choosing us. Before use, please check contents of the package you received as outlined below. If you have any problems or questions with the product, please contact our sales office or representatives.

■ PACKAGE INCLUDES:

- Standard rack mounting frame.....(1)
- Conductive plate (red).....(16)
- Conductive plate (black)(16)

■ MODEL NO.

Confirm Model No. marking on the product to be exactly what you ordered.

■ INSTRUCTION MANUAL

This manual describes necessary points of caution when you use this product, including installation, connection and basic maintenance procedures.

POINTS OF CAUTION

■ ENVIRONMENT

- Indoor use.
- When heavy dust or metal particles are present in the air, install the unit inside proper housing with sufficient ventilation.
- Do not install the unit where it is subjected to continuous vibration. Do not subject the unit to physical impact.
- Environmental temperature must be within -5 to +55°C (23 to 131°F) with relative humidity within 30 to 90% RH in order to ensure adequate life span and operation.

COMPONENT IDENTIFICATION

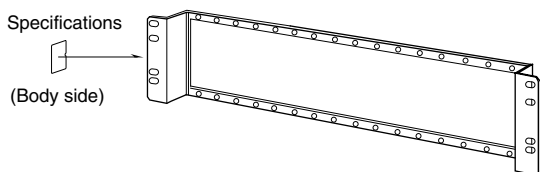

HOW TO CONNECT

Connect signal conditioners to the power distributor via conductive plates as below.
(16 positions max.)

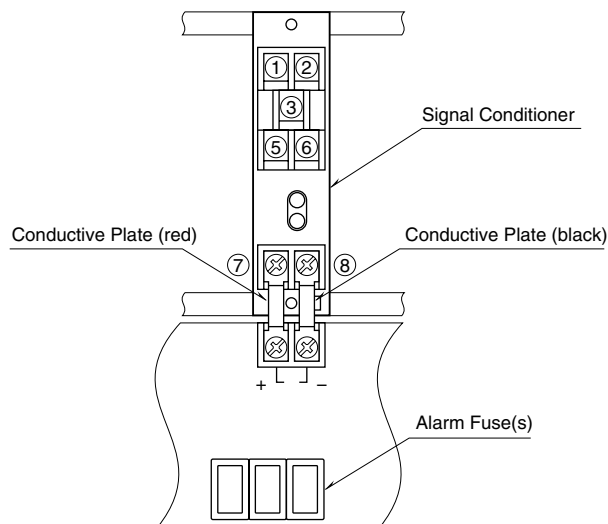

• For H-RACK

Connect terminal 7 of a signal conditioner to a plus terminal of the power distributor via a red conductive plate. Connect terminal 8 of the signal conditioner to a minus terminal of the power distributor via a black conductive plate.

• For M-RACK, W-RACK and A-RACK

Connect terminal 12 of a signal conditioner to a plus terminal of the power distributor via a red conductive plate. Connect terminal 13 of the signal conditioner to a minus terminal of the power distributor via a black conductive plate.

Screw terminal torque: 0.8 N·m

TERMINAL CONNECTIONS

Connect the unit as in the diagram below.

EXTERNAL DIMENSIONS unit: mm (inch)

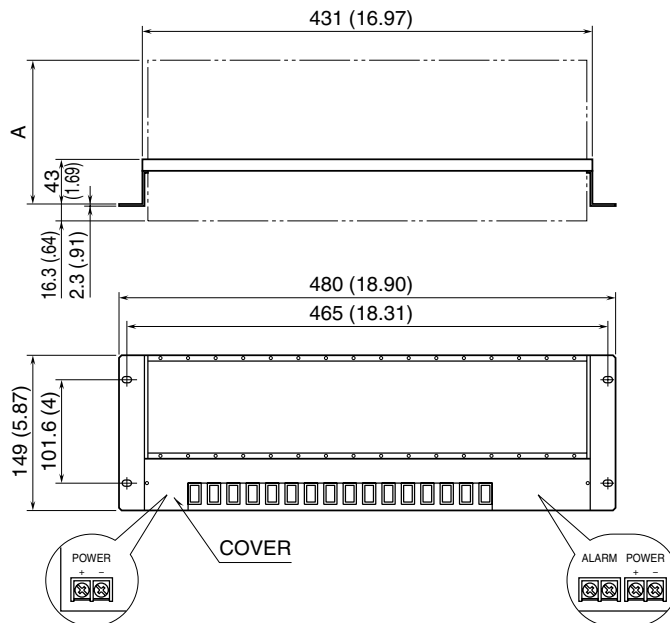

DIMENSIONS	SERIES	M-RACK ^{*1}	H-RACK B-RACK	W-RACK ^{*2}	A-RACK
	A		139 (5.47) [163 (6.42)]	137 (5.39)	[139 (5.47)] 163 (6.42)

*1. Dimensions in parentheses are for 7SN, 7LM, 7LMS

*2. Dimensions in parentheses are for VMS, VFX, JX Series

CONNECTION DIAGRAM

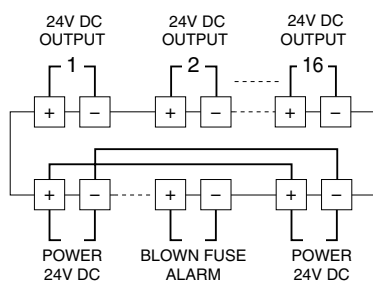

CHECKING

- 1) Terminal wiring: Check that all cables are correctly connected according to the connection diagram.
- 2) Power supply: Check the power supply.
- 3) Alarm contact: Check an alarm fuse when its alarm contact (dry contact) outputs. An alarm indicator turns white when its fuse blow.

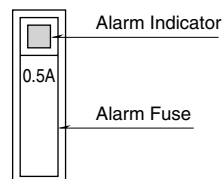

MOUNTING REQUIREMENTS unit: mm (inch)

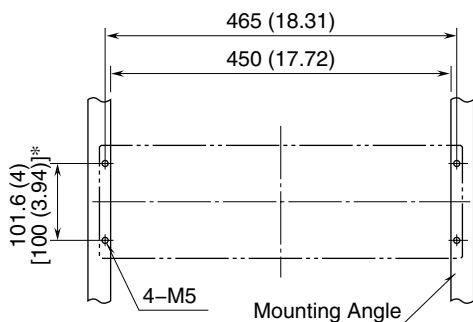

Note: Leave an appropriate amount of space below for wiring.

*Numbers in parentheses are JIS standards

Replace with a new alarm fuse after identifying the cause of blown fuse. For the fuse, consult us.