

<b>FREQUENCY TRANSMITTER</b> (field-configurable)	MODEL <b>B3FP</b>
--	-------------------

**BEFORE USE ....**

Thank you for choosing us. Before use, please check contents of the package you received as outlined below. If you have any problems or questions with the product, please contact our sales office or representatives.

**■ PACKAGE INCLUDES:**

Signal conditioner .....(1)

**■ MODEL NO.**

Confirm Model No. marking on the product to be exactly what you ordered.

**■ INSTRUCTION MANUAL**

This manual describes necessary points of caution when you use this product, including installation, connection and basic maintenance procedures.

**POINTS OF CAUTION**

**■ CONFORMITY WITH UL**

- This equipment is suitable for use in a Pollution Degree 2 environment.
- This equipment is to be used with the maximum operating voltage 30 V rms and 42.4 V peak or 60 V DC.
- The equipment must be mounted inside a suitable fire enclosure.
- Operating temperature: -40 to +55°C (-40 to +131°F)
- Altitude up to 2000 meters.

**■ CONFORMITY WITH EU DIRECTIVES**

- Functional insulation is maintained between signal input and output.
- The input voltage across the terminals must be 70 V or less.
- The equipment must be mounted inside a panel.
- Insert a noise filter for the output/power source connected to the unit. TDK Model ZCAT 3035-1330 or equivalent is recommended.
- The actual installation environments such as panel configurations, connected devices, connected wires, may affect the protection level of this unit when it is integrated in a panel system. The user may have to review the CE requirements in regard to the whole system and employ additional protective measures to ensure the CE conformity.
- Install lightning surge protectors for those wires connected to remote locations.

**■ GENERAL PRECAUTION**

- Before you remove the unit or mount it, turn off the power supply and input signal for safety.

**■ ENVIRONMENT**

- Indoor use.
- When heavy dust or metal particles are present in the air, install the unit inside proper housing with sufficient ventilation.

- Do not install the unit where it is subjected to continuous vibration. Do not subject the unit to physical impact.
- Environmental temperature must be within -40 to +85°C (-40 to +185°F) with relative humidity within 0 to 95% RH in order to ensure adequate life span and operation.
- Be sure that the ventilation slits are not covered with cables, etc.

**■ WIRING**

- Do not install cables close to noise sources (relay drive cable, high frequency line, etc.).
- Do not bind these cables together with those in which noises are present. Do not install them in the same duct.

**■ AND ....**

- The unit is designed to function as soon as power is supplied, however, a warm up for 10 minutes is required for satisfying complete performance described in the data sheet.

**COMPONENT IDENTIFICATION**

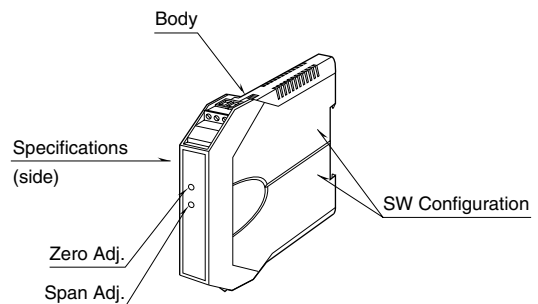

### ■ HOW TO OPEN THE COVER WHEN SETTING DIP SW

Hold at the top and bottom of the unit as shown below and slide the housing cover gently to open until it hits the latching inside the unit.

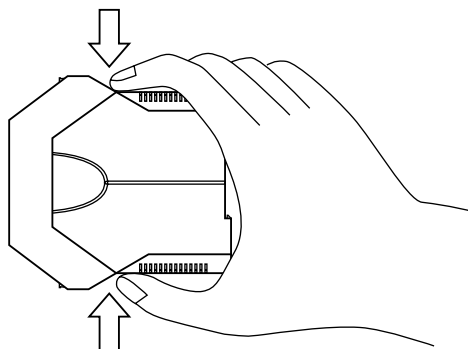

#### • Housing Cover Fully Opened

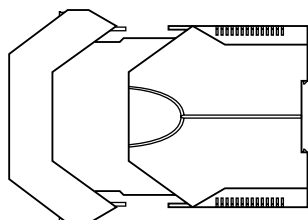

**Caution:** DO NOT PULL beyond where the housing cover is latched. The plastic housing may be damaged.

### ■ HOW TO SEPARATE THE EURO TYPE CONNECTOR TERMINAL BLOCKS

When you need to separate the euro type connector terminal blocks from the transmitter body for wiring, insert a minus driver between the euro type connector terminal block and the housing body, pull up the driver and pull out the euro type connector terminal block.

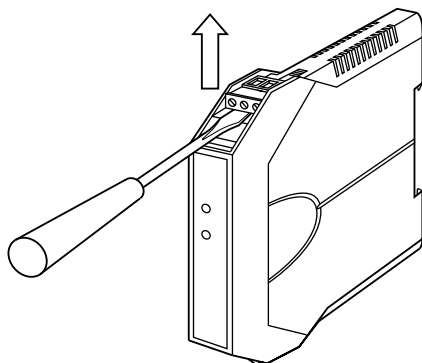

## INSTALLATION

### ■ DIN RAIL MOUNTING

Set the unit so that its DIN rail adaptor is at the bottom. Position the upper hook at the rear side of the unit on the DIN rail and push in the lower. When removing the unit, push down the DIN rail adaptor utilizing a minus screwdriver and pull.

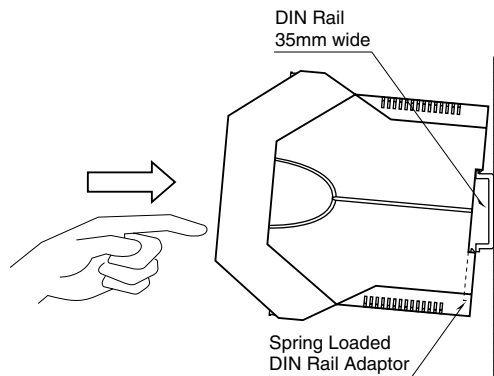

# TERMINAL CONNECTIONS

Connect the unit as in the diagram below or refer to the connection diagram on the side of the unit.

## EXTERNAL DIMENSIONS unit: mm (inch)

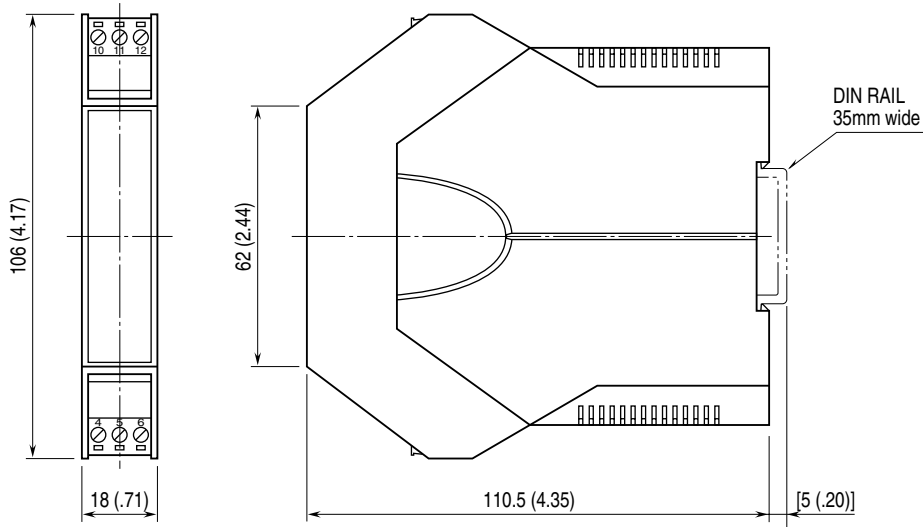

• When mounting, no extra space is needed between units.

## CONNECTION DIAGRAM

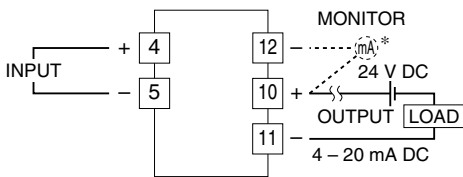

\* DC ammeter's internal resistance 10 ohms max.

### Input Connection Examples

#### Open Collector

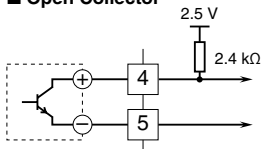

#### Two-wire Current Pulse • External DC Supply

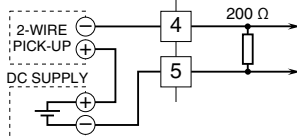

#### Voltage Pulse

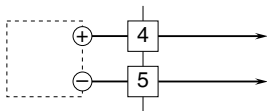

## WIRING INSTRUCTIONS

### Applicable wire size

Solid: 0.2 to 2.5 mm<sup>2</sup> (0.55 to 1.75 dia.)

Stranded: 0.2 to 2.5 mm<sup>2</sup> (Tinning wire ends may cause contact failure and therefore is not recommended.)

Ferruled: 0.2 to 1.5 mm<sup>2</sup> (0.55 to 1.35 dia.)

The following Phoenix Contact terminals are recommended:

AI 0,25-8YE	0.2 to 0.25 mm <sup>2</sup>
AI 0,34-8TQ	0.25 to 0.34 mm <sup>2</sup>
AI 0,5-8WH	0.34 to 0.5 mm <sup>2</sup>
AI 0,75-8GY	0.5 to 0.75 mm <sup>2</sup>
AI 1,0-8RD	0.75 to 1.0 mm <sup>2</sup>
AI 1,5-8BK	1.0 to 1.5 mm <sup>2</sup>

### Expose wire conductors by 8 mm (0.31").

Wire exposure

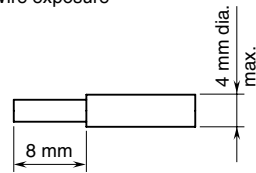

Recommended ferruled wire

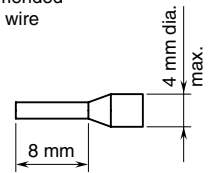

## EXTERNAL VIEWS

### FRONT VIEW

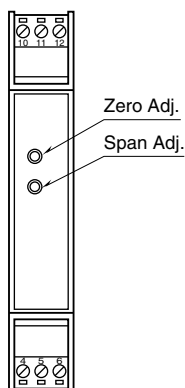

### SIDE VIEW

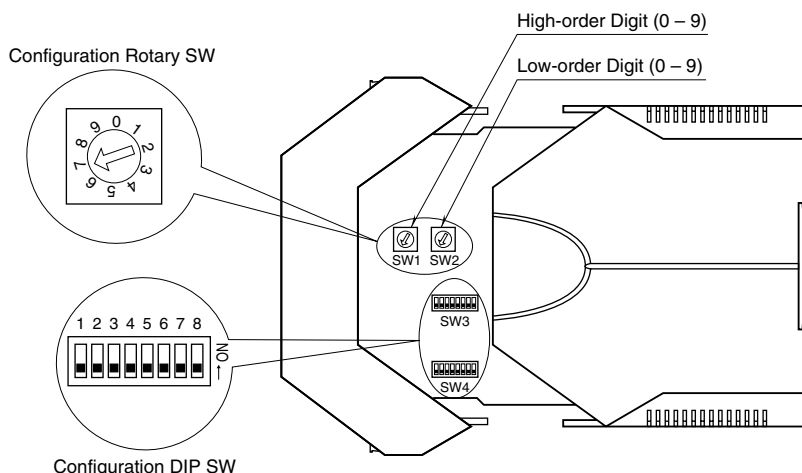

## RANGE CONFIGURATION

### CAUTION !

- With the two-wire current pulse input configuration (SW3-1 ON), DO NOT apply voltage input.
- DO NOT apply voltage exceeding the maximum value of the selected range.
- Applying voltage pulse input greater than the maximum value of the selected range may cause failure of the unit. Check the setting before applying the input signal.

### GENERAL PROCEDURE

First select a coarse range using the internal rotary switches (SW1 and SW2) and DIP switches (SW3 and SW4) according to Tables 1 through 9 below.

Then apply simulated 0% and 100% inputs and fine-tune the output range to 4 mA and 20 mA using the front zero and span adjustments.

### SELECTING DIP SW (coarse adjustment) INPUT TYPE

Choose from Table 1.

Table 1 ■ = ON

INPUT TYPE	SW3-1	SW3-2
Open collector		■
Voltage pulse		
Two-wire current pulse	■	

### FREQUENCY RANGE

Selectable frequency range: 10 mHz to 100 kHz

Set the two most significant digits of the required full-scale frequency with SW1 (high order digit) and SW2 (low order digit) according to Table 2, and then choose the multiplication factor and the frequency unit with SW3 according to Table 3.

Frequency range = [SW1][SW2] × [Factor/Unit (SW3)]

Table 2

FULL-SCALE FREQUENCY (two most significant digits)	SW1 (high)	SW2 (low)
01 to 99	0 to 9	0 to 9

Table 3

■ = ON

MULTIPL. FACTOR / FREQ. UNIT	SW3-4	SW3-5	SW3-6
10 kHz	■	■	■
1 kHz	■	■	
100 Hz	■		■
10 Hz	■		
1 Hz		■	■
100 mHz		■	
10 mHz			■
1 mHz			

[Example] 100% frequency = 32.1 kHz

1) Full-scale frequency

Values of the two significant digits: 32

⇒ Set SW1 to 3, SW2 to 2.

2) Multiplication factor / Frequency unit: According to Table 3, choose '1 kHz.'

⇒ Set SW3-4 and 3-5 to ON.

Coarse frequency range selected with the above switch settings equals: 32 × 1 kHz = 32 kHz.

Fine range is adjusted with the front Zero/Span adjustments after all switch settings are complete.

### FREQUENCY OFFSET

See Table 4.

The offset is defined by the following equation:

$$\text{Offset} = \frac{0\% \text{ Input}}{100\% \text{ Input}} \times 100 (\%)$$

Table 4

■ = ON

FREQUENCY OFFSET	SW3-7	SW3-8
0 - 20%		
20 - 50%	■	■

**PULSE AMPLITUDE**

See Table 5.

Choose '0.1 – 2 V p-p' for open collector input (SW3-2 ON).  
 For a two-wire current pulse input (SW3-1 ON), convert the range to a voltage using the receiving resistor value 200 Ω.

Table 5 ■ = ON

AMPLITUDE	MAX. VOLT	SW4-1	SW4-2
0.1 – 2 V p-p	2 V	■	
2 – 10 V p-p	10 V	■	■
10 – 200 V p-p	100 V*1		■

\*1. Max. voltage across the input terminals: 70 V for conform with EU Directive; 30 V rms, 42.4 V peak or 60 V DC for UL approval.

**DETECTING LEVEL**

Four levels are selectable according to Table 6.  
 Detecting level and deadband values depend upon the pulse amplitude. Refer to Table 7.  
 Choose 'High level' for open collector input (SW3-2 ON).  
 For a two-wire current pulse input (SW3-1 ON), convert the range to a voltage using the receiving resistor value 200 Ω.  
 Choose 'Zero-cross' with the capacitor coupling (SW3-3 OFF).

Table 6 ■ = ON

DETECTING LEVEL	SW4-5	SW4-6	SW4-7	SW4-8
Zero-cross			■	
Low level	■			
Middle level		■		■
High level				■

Table 7 ■ = ON

DETECTING LEVEL	PULSE AMPLITUDE		
	0.1 – 2 V p-p	2 – 10 V p-p	10 – 200 V p-p
Zero-cross	0 V	0 V	0 V
Low level	45 mV	60 mV	300 mV
Middle level	200 mV	400 mV	2 V
High level	1 V	2 V	10 V
DETECTING LEVEL	DEADBAND		
Zero-cross	±15% of Amplitude, ≥ ±45 mV*2		
Low level	±15% of Amplitude, ≥ ±40 mV*2		
Middle level	±15% of Amplitude, ≥ ±80 mV*2		
High level	±40% of Detecting Level		

\*2. Minimum deadband required for the amplitude 0.1 – 2 V p-p.

**PULSE SENSING**

See Table 8.

Duty ratio of the input waveform with the capacitor coupling must be lower than 70% with the amplitude 2 – 200 V p-p, less than 55% with 0.1 – 2 V p-p. If the pulse cannot be detected with 'Zero-cross' setting due to a low duty ratio, set the detecting level to 'Low level' according to Table 6.

Table 8 ■ = ON

PULSE SENSING	SW3-3
Capacitor (AC) coupled	
DC coupled	■

**NOISE FILTER**

See Table 9.

The filter may be activated for frequencies lower than 100 Hz.

Table 9 ■ = ON

FILTER	SW4-3	SW4-4
OFF		
ON; Amplitude 2 – 10 V p-p	■	
ON; Other amplitude		■

**EXAMPLE 1**

Voltage with amplitude 5 V, DC offset 2.5 V, Frequency range 0 – 1 kHz, Duty ratio 50%

- 1) Input type: According to Table 1, choose 'Voltage pulse.'  
 ⇒ Set SW3-1 and SW3-2 remain OFF.
- 2) Frequency range  
 Choose 10 as the two most significant digits. Choose a greater value selectable with SW1 and SW2, i.e. 10 × 100 Hz range rather than 01 × 1 kHz range for better performance.  
 ⇒ According to Table 2, set SW1 to '1' and SW2 to '0'.  
 According to Table 3, choose 100 Hz as the frequency unit.  
 ⇒ Set SW3-4 and SW3-6 to ON.
- 3) Offset

$$\frac{0 \text{ kHz}}{1 \text{ kHz}} \times 100 = 0 (\%)$$

- 4) Pulse amplitude: According to Table 5, choose '2 – 10 V p-p.'  
 ⇒ Set SW4-1 and SW4-2 to ON.

The following settings may be added depending on the actual input signal characteristics.

- 5) Detecting level: According to Table 6, choose 'High level.'  
 ⇒ Set SW4-8 remains ON.
- 6) Pulse sensing: According to Table 8, choose 'DC coupled.'  
 ⇒ Set SW3-3 remains ON.
- 7) Filter: According to Table 9, choose 'OFF.' Filter cannot be used for frequency ranges (100% input) wider than 100 Hz.  
 ⇒ Set SW4-3 and SW4-4 remain OFF.

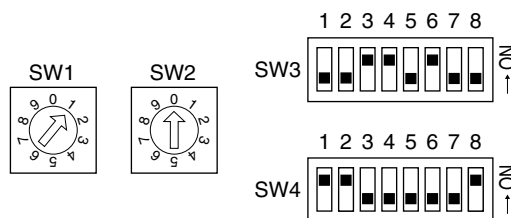

**EXAMPLE 2**

Voltage with amplitude 20 V, DC offset 90 V, Frequency range 25 – 85 Hz, Duty ratio 1%

1) Input type: According to Table 1, choose 'Voltage pulse.'

➡ Set SW3-1 and SW3-2 remain OFF.

2) Frequency range

Choose 85 as the two most significant digits.

➡ According to Table 2, set SW1 to '8' and SW2 to '5.'

According to Table 3, choose 1 Hz as the frequency unit.

➡ Set SW3-5 and SW3-6 to ON.

3) Offset

$$\frac{25 \text{ Hz}}{85 \text{ Hz}} \times 100 = 29.4 (\%)$$

➡ According to Table 4, SW3-7 and SW3-8 to ON.

4) Pulse amplitude: According to Table 5, choose '10 – 200 V p-p.'

➡ Set SW4-2 to ON.

The following settings may be added depending on the actual input signal characteristics.

5) Detecting level: According to Table 6, choose 'Zero-cross.'

➡ Set SW4-7 to ON.

If the input pulse cannot be detected with the above setting, choose 'Low level.'

➡ Set SW4-5 to ON.

6) Pulse sensing: According to Table 8, choose 'capacitor coupled.' DC coupled type is not suitable with the selected detecting level.

➡ Set SW3-3 to OFF.

7) Filter: According to Table 9, choose 'ON, other amplitude.'

➡ Set SW4-4 to ON.

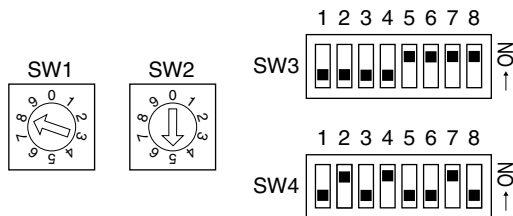
**ZERO & SPAN ADJUSTMENTS (fine adjustments)**

Referring to the instruction manual, apply 0% and 100% input signals and adjust the Zero to have 4 mA output and Span to have 20 mA output respectively.

**CHECKING**

- 1) Terminal wiring: Check that all cables are correctly connected according to the connection diagram.
- 2) DIP SW setting: Check that the switches are set to appropriate positions.
- 3) Input: Check that the input voltage is within 0 – 100% of full-scale.
- 4) Output: Check that the load is within the permissible limit including wiring resistance.

$$\text{Load Resistance } (\Omega) = \frac{\text{Supply Voltage (V)} - 12 \text{ (V)}}{0.02 \text{ (A)}}$$

(including leadwire resistance)

- 5) When you check the output signal, connect an ammeter of which the internal resistance is of 10  $\Omega$  max. to the monitor terminals.

**ADJUSTMENT PROCEDURE**

The input frequency range is finely adjusted to the output as explained in the following.

Adjust the output likewise for matching the signal to a receiving instrument or in case of regular calibration.

**HOW TO CALIBRATE THE OUTPUT SIGNAL**

Use a signal source and measuring instruments of sufficient accuracy level. Turn the power supply on and warm up for more than 10 minutes.

- 1) ZERO: Apply 0% input and adjust output to 0%.
- 2) SPAN: Apply 100% input and adjust output to 100%.
- 3) Check ZERO adjustment again with 0% input.
- 4) When ZERO value is changed, repeat the above procedure 1) – 3).

**MAINTENANCE**

Regular calibration procedure is explained below:

**CALIBRATION**

Warm up the unit for at least 10 minutes. Apply 0%, 25%, 50%, 75% and 100% input signal. Check that the output signal for the respective input signal remains within accuracy described in the data sheet. When the output is out of tolerance, recalibrate the unit according to the "ADJUSTMENT PROCEDURE" explained earlier.

**LIGHTNING SURGE PROTECTION**

We offer a series of lightning surge protector for protection against induced lightning surges. Please contact us to choose appropriate models.