

SIGNAL TRANSMITTER
(field-configurable)

MODEL **B3FV**

BEFORE USE

Thank you for choosing us. Before use, please check contents of the package you received as outlined below. If you have any problems or questions with the product, please contact our sales office or representatives.

■ PACKAGE INCLUDES:

Signal conditioner(1)

■ MODEL NO.

Confirm Model No. marking on the product to be exactly what you ordered.

■ INSTRUCTION MANUAL

This manual describes necessary points of caution when you use this product, including installation, connection and basic maintenance procedures.

POINTS OF CAUTION

■ CONFORMITY WITH UL

- This equipment is suitable for use in a Pollution Degree 2 environment.
- This equipment is to be used with the maximum operating voltage 30 V rms and 42.4 V peak or 60 V DC.
- The equipment must be mounted inside a suitable fire enclosure.
- Operating temperature: -40 to +55°C (-40 to +131°F)
- Altitude up to 2000 meters.

■ CONFORMITY WITH EU DIRECTIVES

- Functional insulation is maintained between signal input and output.
- The input voltage across the terminals must be 70 V or less.
- The equipment must be mounted inside a panel.
- The actual installation environments such as panel configurations, connected devices, connected wires, may affect the protection level of this unit when it is integrated in a panel system. The user may have to review the CE requirements in regard to the whole system and employ additional protective measures to ensure the CE conformity.
- Install lightning surge protectors for those wires connected to remote locations.

■ GENERAL PRECAUTION

- Before you remove the unit or mount it, turn off the power supply and input signal for safety.

■ ENVIRONMENT

- Indoor use.
- When heavy dust or metal particles are present in the air, install the unit inside proper housing with sufficient ventilation.
- Do not install the unit where it is subjected to continuous vibration. Do not subject the unit to physical impact.

- Environmental temperature must be within -40 to +85°C (-40 to +185°F) with relative humidity within 0 to 95% RH in order to ensure adequate life span and operation.
- Be sure that the ventilation slits are not covered with cables, etc.

■ WIRING

- Do not install cables close to noise sources (relay drive cable, high frequency line, etc.).
- Do not bind these cables together with those in which noises are present. Do not install them in the same duct.

■ AND

- The unit is designed to function as soon as power is supplied, however, a warm up for 10 minutes is required for satisfying complete performance described in the data sheet.

COMPONENT IDENTIFICATION

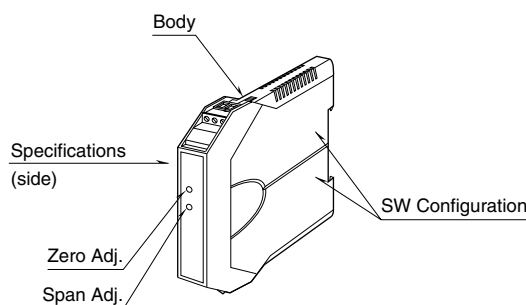

■ HOW TO OPEN THE COVER WHEN SETTING DIP SW

Hold at the top and bottom of the unit as shown below and slide the housing cover gently to open until it hits the latching inside the unit.

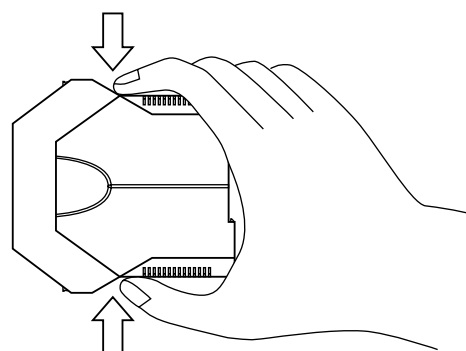

• Housing Cover Fully Opened

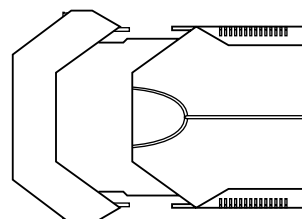

Caution: DO NOT PULL beyond where the housing cover is latched. The plastic housing may be damaged.

HOW TO SEPARATE THE EURO TYPE CONNECTOR TERMINAL BLOCKS

When you need to separate the euro type connector terminal blocks from the transmitter body for wiring, insert a minus driver between the euro type connector terminal block and the housing body, pull up the driver and pull out the euro type connector terminal block.

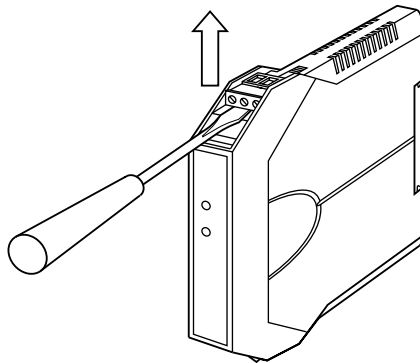

INSTALLATION

DIN RAIL MOUNTING

Set the unit so that its DIN rail adaptor is at the bottom. Position the upper hook at the rear side of the unit on the DIN rail and push in the lower. When removing the unit, push down the DIN rail adaptor utilizing a minus screwdriver and pull.

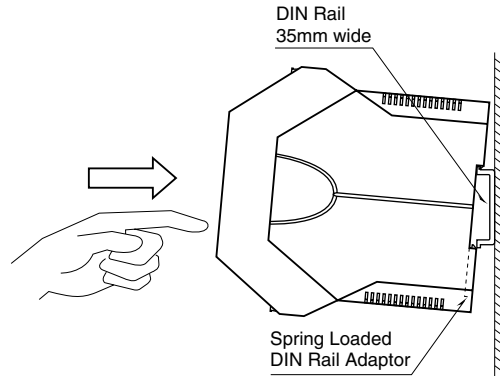

TERMINAL CONNECTIONS

Connect the unit as in the diagram below or refer to the connection diagram on the side of the unit.

EXTERNAL DIMENSIONS unit: mm (inch)

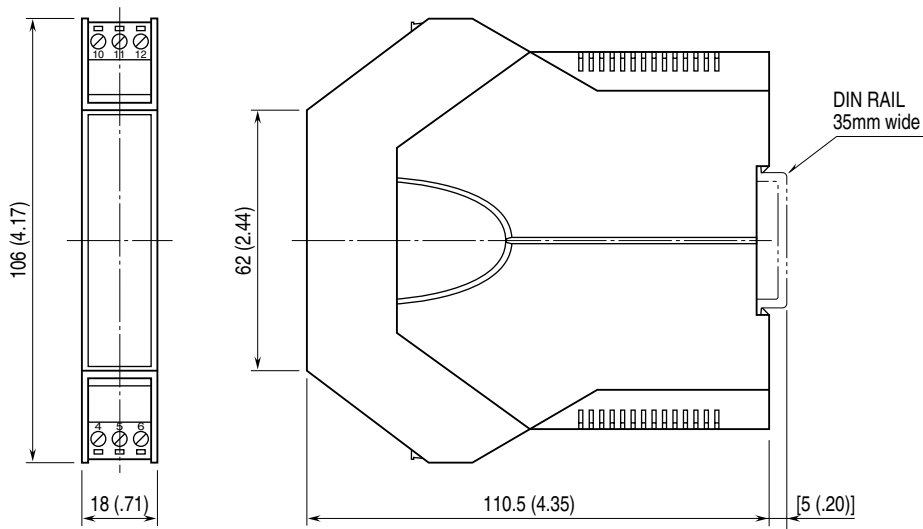

• When mounting, no extra space is needed between units.

CONNECTION DIAGRAM

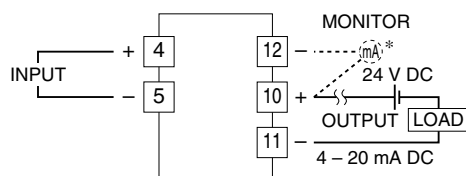

* DC ammeter's internal resistance 10 ohms max.

■ WIRING INSTRUCTIONS

• Applicable wire size

Solid: 0.2 to 2.5 mm² (0.55 to 1.75 dia.)

Stranded: 0.2 to 2.5 mm² (Tinning wire ends may cause contact failure and therefore is not recommended.)

Ferruled: 0.2 to 1.5 mm² (0.55 to 1.35 dia.)

The following Phoenix Contact terminals are recommended:

AI 0,25-8YE 0.2 to 0.25 mm²

AI 0,34-8TQ 0.25 to 0.34 mm²

AI 0,5-8WH 0.34 to 0.5 mm²

AI 0,75-8GY 0.5 to 0.75 mm²

AI 1,0-8RD 0.75 to 1.0 mm²

AI 1,5-8BK 1.0 to 1.5 mm²

• Expose wire conductors by 8 mm (0.31").

Wire exposure

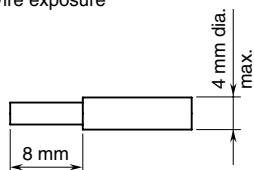

Recommended ferruled wire

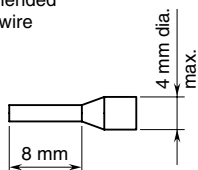

EXTERNAL VIEWS

■ FRONT VIEW

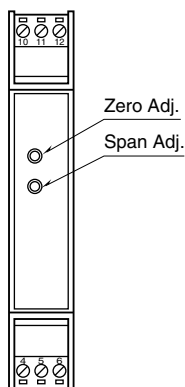

■ SIDE VIEW

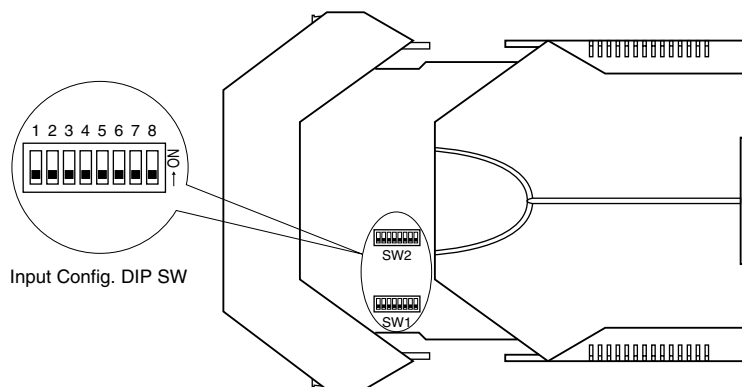

RANGE CONFIGURATION

CAUTION !

- With the current input configuration (SW1-1 ON), DO NOT apply voltage input.
- DO NOT apply voltage exceeding the maximum value of the selected range.
- Applying voltage input greater than the maximum value of the selected range may cause failure of the unit. Check the setting before applying the input signal.

■ GENERAL PROCEDURE

First select a coarse range using the internal DIP switches (SW1 and SW2) according to Tables 2 through 5 below.

Then apply simulated 0% and 100% inputs and fine-tune the output range to 4 mA and 20 mA using the front zero and span adjustments.

■ INPUT TYPE & RANGE

Table 1

INPUT TYPE	MAXIMUM RANGE	SPAN	OFFSET
DC Current	-30 to +30 mA DC	Min. 16 μ A, Max. 60 mA	-100 to +80%
DC Voltage	-100 to +100 V DC *1	Min. 4 mV, Max. 100 V	of the selected range *2

*1. Refer to Table 3 for the maximum value of selectable ranges.

*2. Max. voltage across the input terminals: 70 V for conform with EU Directive; 60 V for UL approval.

SELECTING DIP SW (coarse adjustment)
INPUT TYPE

Choose Current or Voltage according to Table 2.

Table 2

■ = ON

INPUT TYPE	SW1
	1
Current	■
Voltage	

INPUT RANGE

Choose the desired range matching the maximum value and the span according to Table 3.

- For a current input, convert the range to a voltage with the following equation:

$$\text{Voltage} = (100\% \text{ Current} - 0\% \text{ Current}) \times 250 \Omega$$

- When the 0% and 100% values have the same polarity, select the absolute greater value as Span.
- When the 0% and 100% values have opposite polarity, select the absolute difference of the two values (100% - 0%) as Span.
- If the Span value is available in two range selections, select the smaller range. (e.g. Set to the 1 V range for 0 - 1 V, though the maximum value 1 V can be selectable both in 2 V and 1 V range.)
- The minimum span and offset requirements in the table must be met when choosing the desired range.

Table 3

■ = ON

MAX. VALUE OF USABLE RANGE	SPAN	OFFSET	SW1								SW2		
			2	3	4	5	6	7	8	7	8		
100 V	20 V ≤ Span ≤ 100 V	-100 to +80% of the selected range	■										
20 V	4 V ≤ Span ≤ 20 V			■									
10 V	2 V ≤ Span ≤ 10 V				■								
2 V	400 mV ≤ Span ≤ 2 V										■	■	
1 V	200 mV ≤ Span ≤ 1 V							■			■	■	
200 mV	40 mV ≤ Span ≤ 200 mV								■		■	■	
100 mV	20 mV ≤ Span ≤ 100 mV									■	■	■	
20 mV	4 mV ≤ Span ≤ 20 mV										■	■	■

OFFSET

See Table 4.

The offset is defined by the following equation:

$$\text{Offset} = \frac{[0\% \text{ Input}]}{[\text{Max. value of usable range: Table 3}]} \times 100 (\%)$$

Table 4

■ = ON

OFFSET	SW2			
	1	2	3	4
+60% < Offset ≤ +80%	■	■		
+30% < Offset ≤ +60%	■			
+10% < Offset ≤ +30%		■		
-10% ≤ Offset ≤ +10%			■	
-30% ≤ Offset < -10%				■
-60% ≤ Offset < -30%				■
-100% ≤ Offset < -60%			■	■

GAIN

See Table 5.

The gain is defined by the following equation:

$$\text{Gain} = \frac{[\text{Max. value of usable range: Table 3}]}{[100\% \text{ Input} - 0\% \text{ Input}]} \times 100 (\%)$$

Table 5

■ = ON

GAIN	SW2	
	5	6
270% < Gain ≤ 500%		
150% < Gain ≤ 270%		■
100% ≤ Gain ≤ 150%	■	

EXAMPLE

Calibrated input range: 1 - 5 V DC

1) Input type: According to Table 2, choose 'Voltage.'

⇒ Set SW1-1 to OFF.

2) Input range:

5 V > 1 V ⇒ 5 V is used as the maximum value.

According to Table 3, choose '10 V.'

⇒ Set SW1-4 to ON.

3) Offset

$$\frac{1 \text{ V}}{10 \text{ V}} \times 100 = 10 (\%)$$

⇒ According to Table 4, SW2-2 and SW2-3 to ON.

4) Gain

$$\frac{10 \text{ V}}{5 \text{ V} - 1 \text{ V}} \times 100 = 250 (\%)$$

⇒ According to Table 5, set SW2-6 to ON.



ZERO & SPAN ADJUSTMENTS (fine adjustments)

Referring to 'ADJUSTMENT PROCEDURE,' apply 0% and 100% input signals and adjust the Zero to have 4 mA output and Span to have 20 mA output respectively.

CHECKING

- 1) Terminal wiring: Check that all cables are correctly connected according to the connection diagram.
- 2) DIP SW setting: Check that the switches are set to appropriate positions.
- 3) Input: Check that the input voltage is within 0 – 100% of full-scale.
- 4) Output: Check that the load is within the permissible limit including wiring resistance.

$$\text{Load Resistance } (\Omega) = \frac{\text{Supply Voltage (V)} - 12 \text{ (V)}}{0.02 \text{ (A)}}$$

(including leadwire resistance)

- 5) When you check the output signal, connect an ammeter of which the internal resistance is of 10 Ω max. to the monitor terminals.

ADJUSTMENT PROCEDURE

This unit is calibrated at the factory to meet the ordered specifications, therefore you usually do not need any calibration.

For matching the signal to a receiving instrument or in case of regular calibration, adjust the output as explained in the following.

■ HOW TO CALIBRATE THE OUTPUT SIGNAL

Use a signal source and measuring instruments of sufficient accuracy level. Turn the power supply on and warm up for more than 10 minutes.

- 1) ZERO: Apply 0% input and adjust output to 0%.
- 2) SPAN: Apply 100% input and adjust output to 100%.
- 3) Check ZERO adjustment again with 0% input.
- 4) When ZERO value is changed, repeat the above procedure 1) – 3).

MAINTENANCE

Regular calibration procedure is explained below:

■ CALIBRATION

Warm up the unit for at least 10 minutes. Apply 0%, 25%, 50%, 75% and 100% input signal. Check that the output signal for the respective input signal remains within accuracy described in the data sheet. When the output is out of tolerance, recalibrate the unit according to the “ADJUSTMENT PROCEDURE” explained earlier.

LIGHTNING SURGE PROTECTION

We offer a series of lightning surge protector for protection against induced lightning surges. Please contact us to choose appropriate models.