

SERVO-TOP VALVE ACTUATOR TYPE E
(rotary type)

MODEL **EAR70**

BEFORE USE

Thank you for choosing us. Before use, please check contents of the package you received as outlined below. If you have any problems or questions with the product, please contact our sales office or representatives.

■ PACKAGE INCLUDES:

Servo-Top type E.....(1)

■ MODEL NO.

Confirm that the model number described on the product is exactly what you ordered.

■ INSTRUCTION MANUAL

This manual describes necessary points of caution when you use this product, including installation, connection and basic maintenance procedures.

■ SAFETY PRECAUTIONS

Before using this product, read this manual carefully to handle the product correctly. Gain a thorough understanding of this product and all of the instructions and precautions relating to safety before you start using it. Make sure that the end users read this manual and then keep the manual in a safe place for future reference.

⚠ WARNING: Indicates that incorrect handling may cause hazardous conditions, resulting in death or severe injury.

⚠ CAUTION: Indicates that incorrect handling may cause hazardous conditions, resulting in injury or property damage.

⚠ WARNING

- Shut off the all external power supply before wiring to the terminals. Failure to do so may result in electric shock or electric leakage.
- Ground the provided earth screw (M4) on the upper left of the terminal box. Failure to do so may result in operation failure due to damage of printed wiring boards.
- DO NOT open the body cover for the product after installation. Failure to do so may result in electric shock.
- The cover is secured with drop-proof screws. DO NOT remove screws by force. Doing so can cause damage to the product and result in electric shock.
- The enclosure is made of aluminium die-cast. DO NOT drop the product on your feet or fingers. Doing so may cause injury.
- DO NOT install the product where it is exposed to direct sunlight or rain. Doing so may cause failure, electric shock or electric leakage due to dew condensation.
- A fuse is installed on the top side of the control PWB inside the unit for safety. It is 250 V/2 A slow blow type. A spare fuse is secured on the base plate inside the product with adhesive tape. Shut off the power supply before replacing the fuse. Failure to do so may result in electric shock.
- DO NOT step onto the actuator. DO NOT rest a heavy object on or against it. It could cause injury.

- When installing the EAR70 outdoor or where it is exposed to rain or water drops, adequate precaution must be done for preventing water from entering inside through wiring conduits. It could cause electric shock.
- Be sure that the power supply is removed. Hand or arm could be caught and cause injury.

⚠ CAUTION

DO NOT disassemble or repair the product. There are many machined parts such as gears. Doing so may cause injury of fingers.

POINTS OF CAUTION

■ CONFORMITY WITH LOW VOLTAGE DIRECTIVE

- This equipment is suitable for Pollution Degree 2 and Installation Category II (transient voltage 2500V). Reinforced insulation (Power to I/O: 300V, Power to metallic housing: 300V) is maintained. Prior to installation, check that the insulation class of this unit satisfies the system requirements.
- Altitude up to 2000 meters.
- The equipment must be installed such that appropriate clearance and creepage distances are maintained to conform to CE requirements. Failure to observe these requirements may invalidate the CE conformance.

■ POWER INPUT RATING & OPERATIONAL RANGE

Locate the power input rating marked on the product and confirm its operational range as indicated below:
 100 V AC ±10% (50/60 Hz)
 200 V AC ±10% (50/60 Hz)

■ GENERAL PRECAUTIONS

- Remove the power supply to the actuator before wiring to it.
- DO NOT install control signal wires and power supply wires together in one duct and wire from one duct because it may cause a malfunction or failure of printed wiring boards.
 For control signal wires, separate from power supply wires and use shielded cables. This measure reduces the cause of a malfunction or failure.

■ ENVIRONMENT

- Indoor or outdoor, keep away from direct sunlight.
- Operating temperature -10 to +60°C (14 to 140°F)
- Operating humidity 30 to 90% RH (non-condensing)
- Observe at least 200 mm (7.9 in.) of open space at the top of its body cover, if there is a possibility to exchange the actuator.

■ ANTINOISE ELECTRICAL CONNECTION

- Lightning surge protection
In order to protect the unit from lightning surges entering through cables, use of appropriate lightning surge protectors are recommended. Installing a noise filter enables protection from various electrical stresses.
- Ground the earth screw. If the unit is installed in the environment without earthing, it may cause a malfunction or failure.

■ DESIGNING JOINT AND YOKE

- Operate this unit within specified voltage and frequency. The rated output torque is 70 N·m. Do not operate this unit within the condition that the output stem is locked. (The valve stem is locked or more than 120 N·m torque is necessary.) Design the connected stem so that it is not sheared. Observe enough strength when designing the yoke so that there is no bending and distortion.
- Prevent from heat conduction and radiation when connecting surface is high temperature or its radiated heat is high. If the temperature of the unit rises by a heat conducted or radiated from external, it may cause a failure.

■ ENVIRONMENT

- The unit does not endure all vibration at installation site. Even if that is low vibration, the unit cannot be guaranteed over a long period. Please use after evaluation with customer's installation environment. (Particularly avoid using at the place where there is water hammer, steam hammer or cavitation on the valve side.)
- The actuator must be installed in a place where maintenance and inspection can be conducted. Leave spaces of at least 20 cm (7.9 in.) for maintenance and inspection above the unit and around its terminal cover.
- DO NOT use in hazardous atmosphere such like explosive gases, corrosive gases, corrosive liquids or salt pollution.

■ OPERATING CONDITION

- Depending on operating condition, the internal temperature may rise extremely high.
- Operating continuously under such conditions results in short life span or damage of the product and may impair expected performance.
- Operate with an enough margin such as shortening the operational duty time ratio (duty ratio of <50% or less than 13 strokes per minute).

COMPONENT IDENTIFICATION

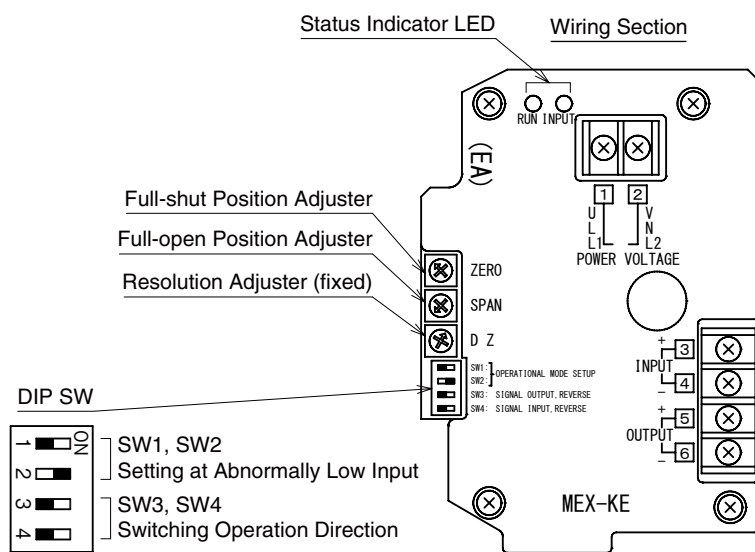
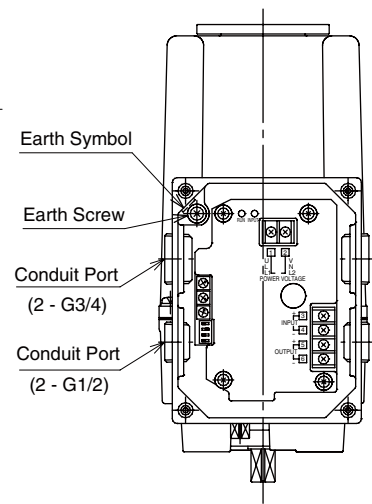
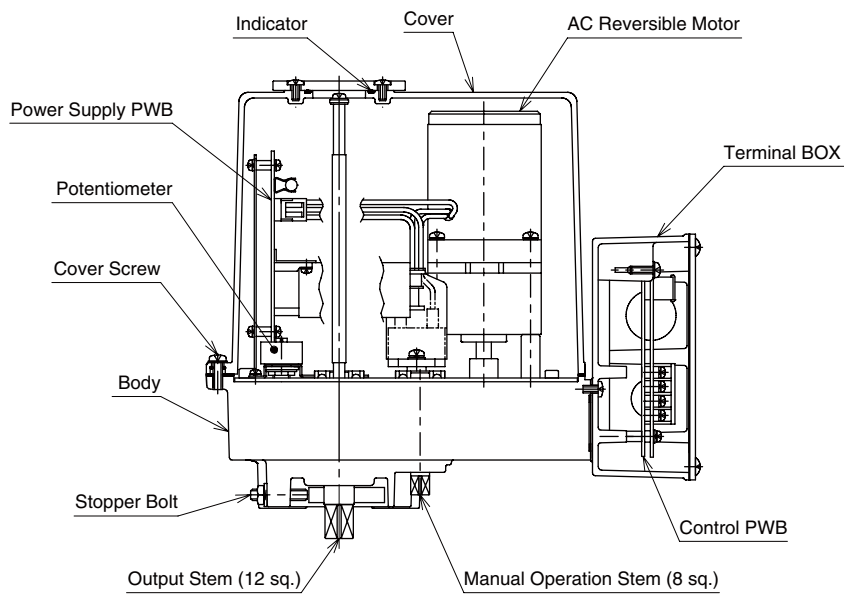
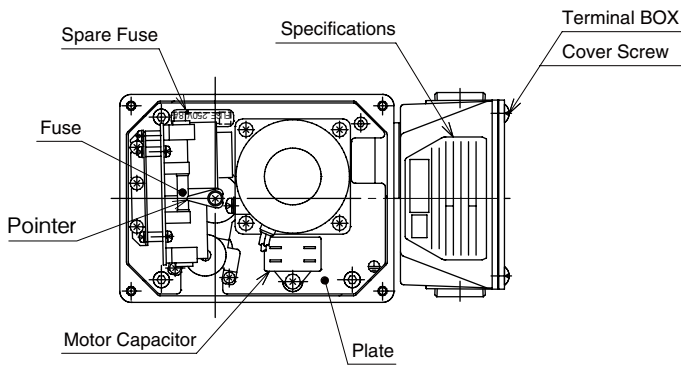

TERMINAL CONNECTIONS

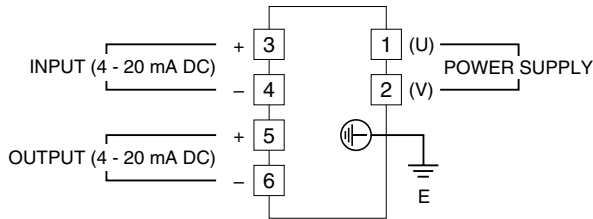

OUTPUT STEM OPERATION

■ DESCRIBING THE CASE OF CCW.

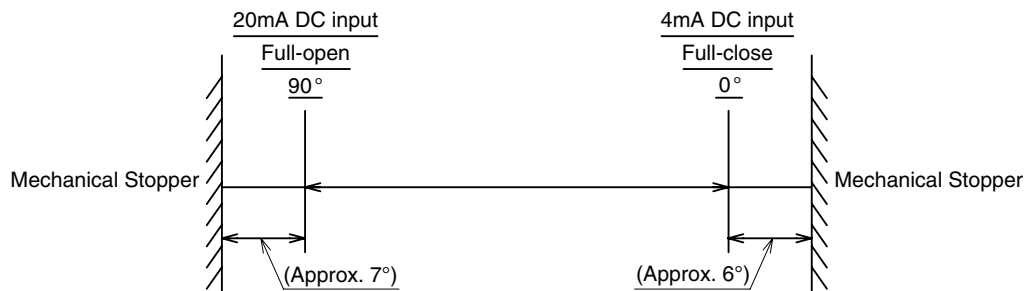

OPERATING MANUAL OPERATION STEM

■ PROCEDURE

- Turn off the power. With power on, the manual operation stem cannot be operated.
- Shape of the manual operation stem is 8 mm square. Use an adequate wrench.
- Moving the output stem to the direction of full-open, turn the manual operation stem to the right viewing from the top of the cover.
- Rotate the manual operation stem while visually checking the indicator (O-S) and the pointer on the top of the cover, and confirming the direction, and the angle (90° to 0°).
- A mechanical stopper is provided inside the machinery to prevent excessive movement when using the manual operation stem. Continuing turning the manual operation stem strongly even though it has hit the mechanical stopper, the inside the machinery may cause malfunction.

SETTING AT ABNORMALLY LOW INPUT

■ Abnormally low input (in case of the CCW.)

The unit detects the abnormally low input when the input signal is lower than 1.48 mA DC (± 0.4 mA DC). (0.37 V DC (± 0.1 V DC) for voltage input.)

The unit also automatically judges the abnormally low input if the input signal is suddenly fallen to the lower of the set value from 20 mA position or middle position.

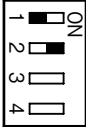
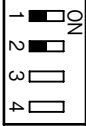
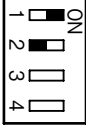
SELECTABLE BY ORDERING INFORMATION	POSITION OF SW1 & SW2	OPERATION (POSITION OF THE OUTPUT STEM)
N		Stem hold at input failure
S		Stem stop at full-shut
O		Stem stop at full-open

Note: Black squares in the above figures show the position of the DIP switch.

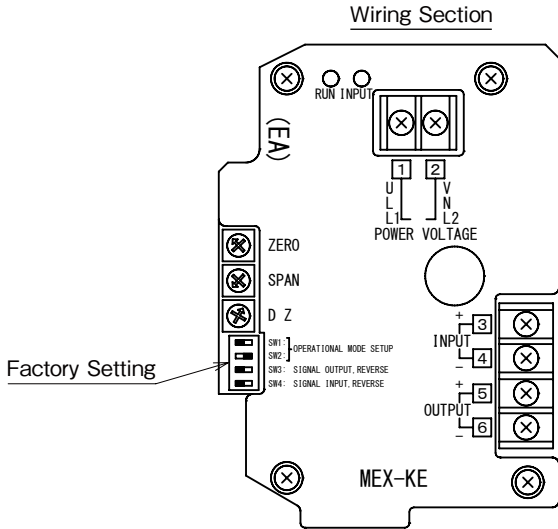

SWITCHING OPERATION DIRECTION

■ CURRENT INPUT

• CCW

INPUT	POSITION OF OUTPUT STEM	ROTATION DIRECTION OF OUTPUT STEM (Viewing from indicator)	OUTPUT	SW
4 mA DC	Shut (0°)	Turn Clockwise SHUT (S)	4 mA DC	
20 mA DC	Open (90°)	Turn Counter Clockwise OPEN (O)	20 mA DC	

· Only reverse the output signal.

20 mA DC	
4 mA DC	

• CW

INPUT	POSITION OF OUTPUT STEM	ROTATION DIRECTION OF OUTPUT STEM (Viewing from indicator)	OUTPUT	SW
4 mA DC	Open (90°)	Turn Counter Clockwise OPEN (O)	4 mA DC	
20 mA DC	Shut (0°)	Trun Clockwise SHUT (S)	20 mA DC	

■ VOLTAGE INPUT

• CCW

INPUT	POSITION OF OUTPUT STEM	ROTATION DIRECTION OF OUTPUT STEM (Viewing from indicator)	OUTPUT	SW
1 V DC	SHut (0°)	Turn Clockwise SHUT (S)	1 V DC	
5 V DC	Open (90°)	Turn Counter Clockwise OPEN (O)	5 V DC	

· Only reverse the output signal.

5 V DC	
1 V DC	

• CW

INPUT	POSITION OF OUTPUT STEM	ROTATION DIRECTION OF OUTPUT STEM (Viewing from indicator)	OUTPUT	SW
1 V DC	Open (90°)	Turn Counter Clockwise OPEN (O)	1 V DC	
5 V DC	Shut (0°)	Turn Counter Clockwise SHUT (S)	5 V DC	

Note: Black squares in the above figures show the position of the DIP switch.

ANGLE OF OUTPUT STEM FINE ADJUSTMENT

Use "ZERO" adjuster to fine-adjust output stem angle of full-shut position.

Use "SPAN" adjuster to fine-adjust output stem angle of full-open position.

Operation direction of output stem differs according to the rotation direction of each adjuster as following.

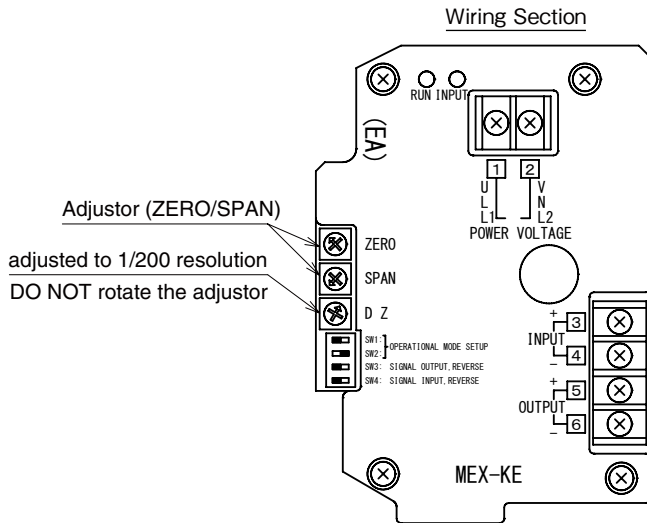
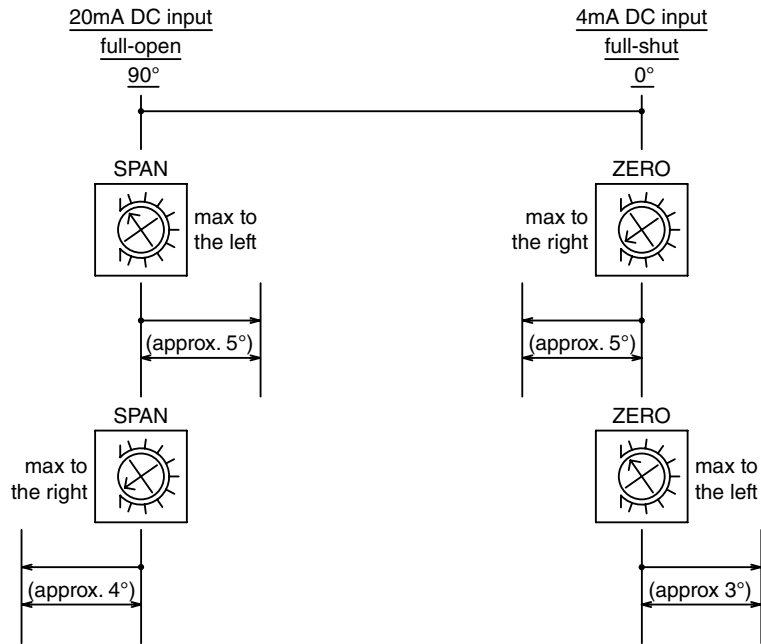

MAINTENANCE

For effective use and longer life of the unit, regular checking appropriate at once a year is recommended. In the case regular checking is not performed, the unit may result in failure for shorter life-span depending on its operating conditions.

■ CHECKING POINT

- Check the main power voltage. (voltmeter)
- Measure the open-shut operation time. (stopwatch)
- No abnormal noise during open-shut operation. (auditory)
- No rust, no corrosion inside the machinery. (visual)
- Non condensing inside the machinery. (visual)
- No discolored parts inside the machinery where can be visually checked. (visual)
- No significant vibration variation from the time of installation during operation. (tactile)
- No deterioration and changes of the packing and O-ring between the mechanism and the cover, and on the inner surface of the lid of the BOX. (visual)

■ NO NECESSARY CHECKING POINT

There is no need of lubrication for the transmission gear mechanism inside the machinery.

The mechanism is lubricated with organic molybdenum grease. There is no oil separation from thickener due to high or low temperature, or frequent operation. (While using, the oil color changes to kind of black. It is no problem for quality.)

■ REGULAR TEST RUNNING

If the valve is not frequently operated, run a test operation regularly (once a week, for example) to check proper functions.

FAILURE AND PROVISION

■ NO OPERATION

First, perform the checking point.

- Replacing the fuse: Exchanging the parts
- Rust and corrosion inside the machinery: Exchanging the unit
- Failure on power circuit and control PWB: Exchanging the unit
- Degradation of various parts due to end of life-span: Exchanging the unit