

ETHERNET TOWER LIGHT
(small size, 40 mm dia., Modbus/TCP, 1 - 5 layers)

MODEL **IT40SRE2**

BEFORE USE

Thank you for choosing us. Before use, please check contents of the package you received as outlined below. If you have any problems or questions with the product, please contact our sales office or representatives.

This equipment is for use in general industrial environments, therefore may not be suitable for applications which require higher level of safety (e.g. safety or accident prevention systems) or of reliability (e.g. vehicle control or combustion control systems). For safety, installation and maintenance of this equipment must be conducted by qualified personnel.

■ PACKAGE INCLUDES:

Tower Light(1)

■ MODEL NO.

Confirm Model No. marking on the product to be exactly what you ordered.

■ INSTRUCTION MANUAL

This manual describes necessary points of caution when you use this product, including installation, connection and basic maintenance procedures.

■ SYMBOLS USED ON THE PRODUCT AND IN THIS MANUAL

△ The symbol indicated on the equipment means that the user must refer to the related parts in the manual for safe operation of the equipment. It is essential to read the instructions wherever the symbol appears in the manual.

△ **WARNING:** is reserved for conditions and actions that can cause serious or fatal injury.

△ **CAUTION:** is reserved for conditions and actions that can cause injury or instrument damage.

⚠ CAUTION

■ REGARDING SAFETY

- If the equipment is used in a manner not specified by us, the protection provided by the equipment may be impaired.

■ CONFORMITY WITH EU DIRECTIVES

- This equipment is suitable for Installation Category II (transient voltage 2500V) and Pollution Degree 2. Reinforced insulation (network to power: 300V) is maintained. Prior to installation, check that the insulation class of this unit satisfies the system requirements.
- Altitude up to 2000 meters.
- The equipment must be installed such that appropriate clearance and creepage distances are maintained to conform to CE requirements. Failure to observe these requirements may invalidate the CE conformance.
- The actual installation environments such as panel configurations, connected devices, connected wires, may affect the protection level of this unit when it is integrated in a panel system. The user may have to review the CE requirements in regard to the whole system and employ additional protective measures* to ensure the CE conformity.

- * For example, installation of noise filters and clamp filters for the power source, input and output connected to the unit, etc.

- The equipment is intended to be installed in a industrial environment defined by EN 60947-5-1.

POINTS OF CAUTION

■ POWER INPUT RATING & OPERATIONAL RANGE

- Locate the power input rating marked on the product and confirm its operational range as indicated below:

100 – 240 V AC rating: 85 – 264 V, 47 – 66 Hz,
approx. 8 VA at 100 V AC
approx. 10 VA at 200 V AC
approx. 11 VA at 240 V AC

24 V DC rating: 24 V ±10 %, approx. 4 W

■ GENERAL PRECAUTIONS

- Before you remove the unit or mount it, turn off the power supply and input signal for safety.
- The unit must not be subjected to external force.
- Do not rub the unit with organic solvent like paint thinner.

■ ENVIRONMENT

- Indoor use.
- Do not install the unit where it is subjected to continuous vibration. Do not subject the unit to physical impact.
- Environmental temperature must be within -10 to +55°C (14 to 131°F) with relative humidity within 30 to 90% RH in order to ensure adequate life span and operation.
- Mount the unit on a flat and robust plate.
- Lamps are omnidirectional.
- The buzzer sound is directional in front of the unit.
Rated voltage of buzzer: 12 V DC
(Operational voltage: 7 - 13 V DC)
Buzzer volume: approx. 71 - 78 dB
(Buzzer aperture (front) direction: 1 m, A-weighting)

■ INGRESS PROTECTION (IP65)

- The IP code is conformable when the unit is mounted vertically, and the control panel cover is locked. The compartment, where connectors are located, is not protected.
- When opening the control panel cover, avoid humidity and dust penetration. Dry and clean it if condensation is formed, and close the cover locking tightly.
- In order to protect ingress of water or dust into the bottom compartment, mount the unit on the flat plane, and be sure that the gasket does not roll back or dust is not on the gasket.

■ WIRING

- Do not install cables close to noise sources (relay drive cable, high frequency line, etc.).
- Do not bind these cables together with those in which noises are present. Do not install them in the same duct.

■ AND

- The unit is designed to function as soon as power is supplied, however, a warm up for 10 minutes is required for satisfying complete performance described in the data sheet.

COMPONENT IDENTIFICATION

■ FRONT VIEW (When the cover is opened)

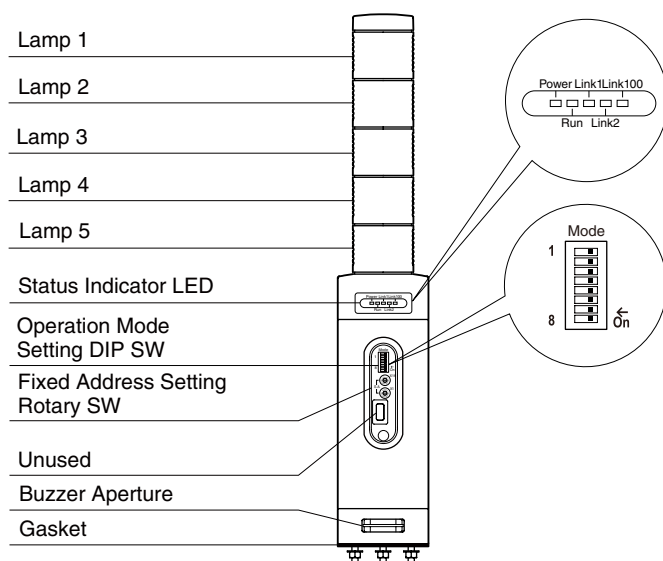

■ STATUS INDICATOR LED

ID	COLOR	FUNCTION
Power	Green	Turns on when the power is supplied normally.
Run	Green	Turns on in normal communications conditions.
Link1	Green	Turns on when communication line 1 is in Link status.
Link2	Green	Turns on when communication line 2 is in Link status.
Link100	Green	Turns on in 100BASE link.

■ OPERATING MODE

(*) Factory setting

• Lamp Blinking Frequency: Mode-1

SW3-1	LAMP BLINKING FREQUENCY
OFF	Approx. 2 Hz (*)
ON	Approx. 10 Hz

• Buzzer Intermittent Frequency: Mode-2

SW3-2	BUZZER INTERMITTENT FREQUENCY
OFF	Approx. 2 Hz (*)
ON	Approx. 10 Hz

• Buzzer Volume: Mode-3, Mode-4

SW3-3	SW3-4	BUZZER VOLUME
OFF	OFF	Quiet (*)
OFF	ON	Middle
ON	OFF	Loud
ON	ON	Maximum

• Output at the Loss of Communication: Mode-6

SW3-6	OUTPUT AT THE LOSS OF COMMUNICATION
OFF	Reset the output (turned off) (*)
ON	Hold the output (maintains the last data received normally)

• IP address reset

SW3-8	IP ADDRESS RESET
OFF	Operating (*)
ON	IP address returns to factory default (after restarting the unit)

Note 1: Other network settings are also reset to default.

Note 2: Be sure to set unused SW3-5 and 7 to OFF.

■ IP ADDRESS

Set the host address (2-digit hexadecimal number) in the IP address using rotary switches SA1 and SA2 for the first digit and the second digit, respectively.

When using the host address in the IP address set with Web browser, set the switches to '00H'.

When the network address, Subnet Mask, and Default Gateway need to be changed, do so with Web browser.

Set the rotary switches to 'FFH' in order to enable the DHCP client function.

(Setting range: 00H – FFH)

(Factory setting: 00H)



IP Address Host Address LSD (x16)



IP Address Host Address MSD (x1)

TERMINAL CONNECTIONS

Connect the unit as in the diagram below.

EXTERNAL DIMENSIONS unit: mm

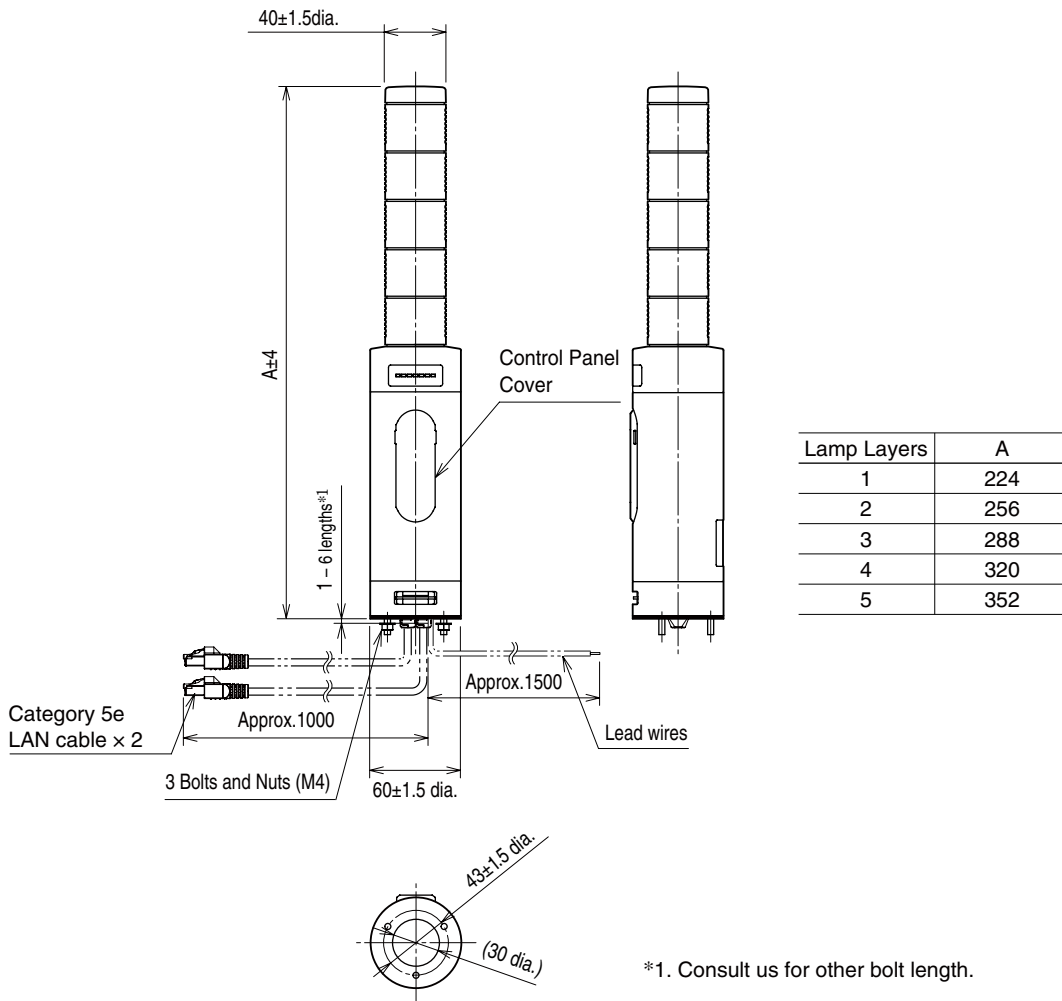

*1. Consult us for other bolt length.

CONNECTION DIAGRAM

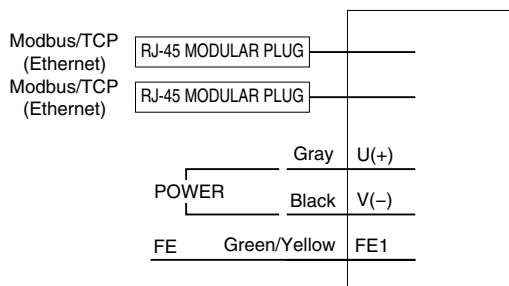

MOUNTING REQUIREMENTS unit: mm

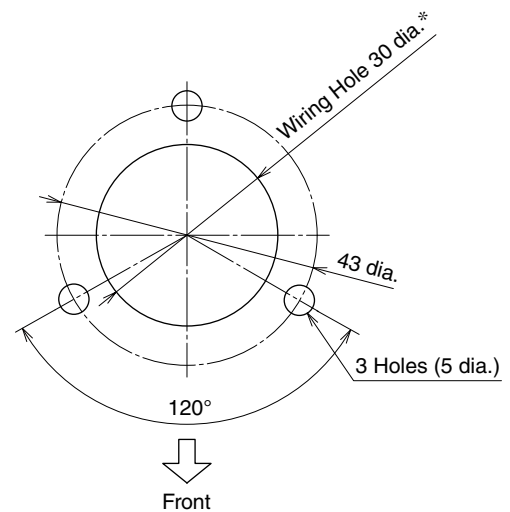

*Protect wires to prevent scratching them at the edge of the compartment.

CHECKING ETHERNET CONNECTION

■ IP ADDRESS

Only the host address is selectable with the rotary switches (setting range: 01H - FEH). Change other parameters with Web browser. Set the rotary switches to '00H' in order to enable Web browser setting.

DHCP client function is supported. Set the rotary switches to 'FFH' in order to enable the DHCP client function.

The Modbus/TCP Port No. is fixed at 502.

■ CHECK WIRING

Connect to PC.

■ CHECK INDICATOR

When wiring is correct, Link1 (Link2) is turned on.

■ CHECK TOWER LIGHT CONNECTION

Enter "ping command" on the character user interface (CUI) such as Windows PowerShell or command prompt:

```
C:\WINDOWS>ping *.*.*.*.*  
(*.*.*.*.*: Enter IP address in decimal.)
```

```
ping *.*.*.*.* with 32 bytes of data:  
Reply from *.*.*.*.* : bytes = 32 time < 10ms TTL = 64  
Reply from *.*.*.*.* : bytes = 32 time < 10ms TTL = 64  
Reply from *.*.*.*.* : bytes = 32 time < 10ms TTL = 64  
Reply from *.*.*.*.* : bytes = 32 time < 10ms TTL = 64
```

```
Ping statistics for *.*.*.*.*  
Packets: Sent = 4, Received = 4, Lost = 0 (0% loss)
```

Replies in case of normal connection are as shown above. If the connection cannot be established normally due to e.g. wrong IP address, other replies such as 'timeout' will be received.

■ CHECK CONNECTION TO THE APPLICATION SOFTWARE

Check Point 1: Link indicators

When normal connection is established, the front Link is turned on regardless of data sending/receiving status. Check the network in case that the indicator is not on.

Check Point 2: Run indicator

A green light turns on at the Run indicator when data is sent/received normally.

MODBUS FUNCTION CODES & SUPPORTED CODES

■ Data and Control Functions

CODE	NAME		
01	Read Coil Status	X	Digital output from the slave
02	Read Input Status	X	Status of digital inputs to the slave
03	Read Holding Registers		General purpose register within the slave
04	Read Input Registers		Collected data from the field by the slave
05	Force Single Coil	X	Digital output from the slave
06	Preset Single Register	X	General purpose register within the slave
07	Read Exception Status		
08	Diagnostics		
09	Program 484		
10	Poll 484		
11	Fetch Comm. Event Counter		Fetch a status word and an event counter
12	Fetch Comm. Event Log		A status word, an event counter, a message count and a field of event bytes
13	Program Controller		
14	Poll Controller		
15	Force Multiple Coils	X	Digital output from the slave
16	Preset Multiple Registers		General purpose register within the slave
17	Report Slave ID		Slave type / 'RUN' status
18	Program 884/M84		
19	Reset Comm. Link		
20	Read General Reference		
21	Write General Reference		
22	Mask Write 4X Register		
23	Read/Write 4X Registers		
24	Read FIFO Queue		

■ Exception Codes

CODE	NAME		
01	Illegal Function	X	Function code is not allowable for the slave
02	Illegal Data Address	X	Address is not available within the slave
03	Illegal Data Value	X	Data is not valid for the function
04	Slave Device Failure		
05	Acknowledge		
06	Slave Device Busy		
07	Negative Acknowledge		
08	Memory Parity Error		

MODBUS I/O ASSIGNMENTS

	ADDRESS	DATA TYPE	DATA
Coils (0X)	1 – 16		Digital Output (lamp, buzzer)
	17 – 32		Reserved (unused)
Inputs (1X)	1 – 16		Reserved (unused)
	17 – 32		Reserved (unused)
	33 – 48		Reserved (unused)
	49 – 64		Reserved (unused)
Input Registers (3X)	1 – 48	----	Reserved (unused)
Holding Registers (4X)	1 – 48	----	Reserved (unused)

■ OUTPUT DATA

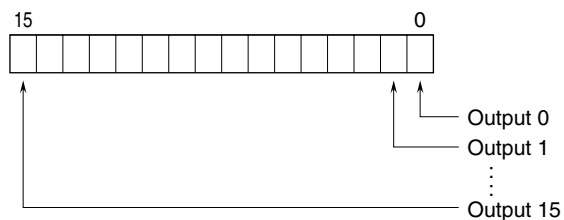

Output 0	Lamp 1	0: Off, 1: On
Output 1	Lamp 2	0: Off, 1: On
Output 2	Lamp 3	0: Off, 1: On
Output 3	Lamp 4	0: Off, 1: On
Output 4	Lamp 5	0: Off, 1: On
Output 5	Buzzer	0: Off, 1: Continuous
Output 6		
Output 7		
Output 8	Lamp 1	0: Off, 1: Blinking
Output 9	Lamp 2	0: Off, 1: Blinking
Output 10	Lamp 3	0: Off, 1: Blinking
Output 11	Lamp 4	0: Off, 1: Blinking
Output 12	Lamp 5	0: Off, 1: Blinking
Output 13	Buzzer	0: Off, 1: Intermittent
Output 14		
Output 15		

Note: If "On" (Continuous) and "Blinking" (Intermittent) are set simultaneously for a single lamp (buzzer), "Blinking" (Intermittent) is disabled.

WEB BROWSER CONFIGURATION

Configure the web browser settings as follows.

SYSTEM REQUIREMENT

ITEM	REQUIREMENT
PC	Ethernet function is available
OS	Windows 11
Browser	Microsoft Edge (Confirmed version: 141.0.3537.71)

HOW TO CONNECT TO DEVICE

Start the browser and enter `http://[IP address of ITxSRE2]` (default: 192.168.0.1) in the address bar to access the setting window.

IT40SRE2-5RYGBW Configuration

Device Information
Modbus Information
Network Setting
Modbus Setting
Monitor

Device Information

Firmware Version	1.0.0.0
Build Date	Mar 10 2025 11:39:35
MAC Address	00:10:9C:12:34:56
Serial Number	123456

WINDOW DESCRIPTION

1. Device Information

Settings cannot be changed.

IT40SRE2-5RYGBW Configuration

Device Information
Modbus Information
Network Setting
Modbus Setting
Monitor

Device Information

Firmware Version	1.0.0.0
Build Date	Mar 10 2025 11:39:35
MAC Address	00:10:9C:12:34:56
Serial Number	123456

- Firmware Version
- Build Date: The date when firmware was built.
- MAC Address
- Serial Number

2. Modbus Information

Settings cannot be changed.

IT40SRE2-5RYGBW Configuration

Device Information
Modbus Information
Network Setting
Modbus Setting
Monitor

Modbus Information

RX Frame	0
RX Error Frame	0
TX Frame	0
TX Exception Frame	0

ITEM	DESCRIPTION
RX Frame	Receive frames
RX Error Frame	Error receive frames
TX Frame	Transfer frames
TX Exception Frame	Transfer exception frames

3. Network Setting

Settings such as IP address of the device can be changed.

IT40SRE2-5RYGBW Configuration

Device Information
Modbus Information
Network Setting
Modbus Setting
Monitor

Network Setting

IP Address	192.168.0.1
Subnet Mask	255.255.255.0
Default Gateway	0.0.0.0

ITEM	SETTING RANGE	DEFAULT SETTING
IP Address	1.0.0.0 – 255.255.255.255	192.168.0.1
Subnet Mask	224.0.0.0 – 255.255.255.255	255.255.255.0
Default Gateway	0.0.0.0 – 255.255.255.255	0.0.0.0

Note: Setting can be configured only when the rotary switch is 00H.

4. Modbus Setting

Settings can be configured.

- Port No.: The port number for Modbus is set to 502. Do not change it when using as Modbus.
- Connection Timeout: The time until TCP/IP is disconnected in no-communication state.
- RUN Timeout: The time until the Run indicator turns off in no-communication state.

IT40SRE2-5RYGBW Configuration

Device Information
Modbus Information
Network Setting
Modbus Setting
Monitor

Modbus Setting

Port No	502
Connection Timeout	60.0
RUN Timeout	5.0

ITEM	SETTING RANGE	DEFAULT SETTING
Port No	1 – 65535	502
Connection Timeout	0.0 – 3200.0 (sec.)	60.0
RUN Timeout	0.0 – 3200.0 (sec.)	5.0

Note: If the Connection Timeout and RUN Timeout are 0, the timeout process is disabled.

5. Monitor

Lamps and buzzer can be output to the monitor.

Set SW3-6 to ON (hold the output) when outputting to the monitor.

- ON: Lamps turn on. The buzzer sound is output continuously.
- BLINK: Lamps blink.
- INTERMITTENT: The buzzer sound is output intermittently.

IT40SRE2-5RYGBW Configuration

Device Information
Modbus Information
Network Setting
Modbus Setting
Monitor

Monitor

Lamp 1 (Red)		OFF ON BLINK
Lamp 2 (Yellow)		OFF ON BLINK
Lamp 3 (Green)		OFF ON BLINK
Lamp 4 (Blue)		OFF ON BLINK
Lamp 5 (White)		OFF ON BLINK
Buzzer	🔊	OFF ON INTERMITTENT

Switch Status

SW 1	0x00
SW 2	0x00
SW 3	0x00

ITEM	SETTING RANGE	DEFAULT SETTING
Lamp 1	OFF/ON/BLINK	OFF
Lamp 2	OFF/ON/BLINK	OFF
Lamp 3	OFF/ON/BLINK	OFF
Lamp 4	OFF/ON/BLINK	OFF
Lamp 5	OFF/ON/BLINK	OFF
Buzzer	OFF/ON/INTERMITTENT	OFF
SW 1	–	0x00
SW 2	–	0x00
SW 3	–	0x00

■ HOW TO CONFIGURE SETTINGS

Change a setting value and click [Submit] button. The following example is Modbus setting window.

IT40SRE2-5RYGBW Configuration

Device Information
Modbus Information
Network Setting
Modbus Setting
Monitor

Modbus Setting

Port No	502
Connection Timeout	60.0
RUN Timeout	5.0

When the configuration succeeded, the following window appears.

IT40SRE2-5RYGBW Configuration Success!

Configuration update successfully.
Please restart device.

Click [Restart] button to confirm whether to restart the device.
Click [OK] button to restart the device. The setting is applied.

192.168.0.1 の内容

Restart Device?

Configuration update successfully.
Please restart device.

When the specified setting value is out of setting range, the following message appears.

192.168.0.1 の内容

Invalid Value

Device Information
Modbus Information
Network Setting
Modbus Setting
Monitor

Modbus Setting

Port No	65536
Connection Timeout (0.1[Sec])	600
RUN Timeout (0.1[Sec])	50

Click [OK] button and close the message. Then, the error value is highlighted.

IT40SRE2-5RYGBW Configuration

Device Information	Modbus Information	Network Setting	Modbus Setting	Monitor
Modbus Setting				
Port No	65536			
Connection Timeout (0.1[Sec])	600			
RUN Timeout (0.1[Sec])	50			
<input type="button" value="Submit"/>				