

EtherNet/IP TOWER LIGHT
(small size, 40 mm dia., 1 - 5 layers)

MODEL **IT40SREIP**

BEFORE USE

Thank you for choosing us. Before use, please check contents of the package you received as outlined below.

If you have any problems or questions with the product, please contact our sales office or representatives.

This equipment is for use in general industrial environments, therefore may not be suitable for applications which require higher level of safety (e.g. safety or accident prevention systems) or of reliability (e.g. vehicle control or combustion control systems). For safety, installation and maintenance of this equipment must be conducted by qualified personnel.

■ PACKAGE INCLUDES:

Tower Light(1)

■ MODEL NO.

Confirm Model No. marking on the product to be exactly what you ordered.

■ INSTRUCTION MANUAL

This manual describes necessary points of caution when you use this product, including installation, connection and basic maintenance procedures.

■ EDS FILE

EDS files are downloadable at our web site.

■ SYMBOLS USED ON THE PRODUCT AND IN THIS MANUAL

△ The symbol indicated on the equipment means that the user must refer to the related parts in the manual for safe operation of the equipment. It is essential to read the instructions wherever the symbol appears in the manual.

△ **WARNING:** is reserved for conditions and actions that can cause serious or fatal injury.

△ **CAUTION:** is reserved for conditions and actions that can cause injury or instrument damage.

⚠ CAUTION

■ REGARDING SAFETY

- If the equipment is used in a manner not specified by us, the protection provided by the equipment may be impaired.

■ CONFORMITY WITH EU DIRECTIVES

- This equipment is suitable for Installation Category II (transient voltage 2500V) and Pollution Degree 2. Reinforced insulation (network to power: 300V) is maintained. Prior to installation, check that the insulation class of this unit satisfies the system requirements.
- Altitude up to 2000 meters.
- The equipment must be installed such that appropriate clearance and creepage distances are maintained to conform to CE requirements. Failure to observe these requirements may invalidate the CE conformance.

- The actual installation environments such as panel configurations, connected devices, connected wires, may affect the protection level of this unit when it is integrated in a panel system. The user may have to review the CE requirements in regard to the whole system and employ additional protective measures* to ensure the CE conformity.

* For example, installation of noise filters and clamp filters for the power source, input and output connected to the unit, etc.

- The equipment is intended to be installed in a industrial environment defined by EN 60947-5-1.

POINTS OF CAUTION

■ POWER INPUT RATING & OPERATIONAL RANGE

- Locate the power input rating marked on the product and confirm its operational range as indicated below:

100 – 240 V AC rating: 85 – 264 V, 47 – 66 Hz,
approx. 10 VA at 100 V AC
approx. 13 VA at 200 V AC
approx. 14 VA at 240 V AC

24 V DC rating: 24 V ±10 %, approx. 5.5 W

■ GENERAL PRECAUTIONS

- Before you remove the unit or mount it, turn off the power supply and input signal for safety.
- The unit must not be subjected to external force.
- Do not rub the unit with organic solvent like paint thinner.

■ ENVIRONMENT

- Indoor use.
- Do not install the unit where it is subjected to continuous vibration. Do not subject the unit to physical impact.
- Environmental temperature must be within -10 to +55°C (14 to 131°F) with relative humidity within 30 to 90% RH in order to ensure adequate life span and operation.
- Mount the unit on a flat and robust plate.
- Lamps are omnidirectional.
- The buzzer sound is directional in front of the unit.
Rated voltage of buzzer: 12 V DC
(Operational voltage: 7 - 13 V DC)
Buzzer volume: approx. 71 - 78 dB
(Buzzer aperture (front) direction: 1 m, A-weighting)

■ INGRESS PROTECTION (IP65)

- The IP code is conformable when the unit is mounted vertically, and the control panel cover is locked. The compartment, where connectors are located, is not protected.
- When opening the control panel cover, avoid humidity and dust penetration. Dry and clean it if condensation is formed, and close the cover locking tightly.
- In order to protect ingress of water or dust into the bottom compartment, mount the unit on the flat plane, and be sure that the gasket does not roll back or dust is not on the gasket.

■ **WIRING**

- Do not install cables close to noise sources (relay drive cable, high frequency line, etc.).
- Do not bind these cables together with those in which noises are present. Do not install them in the same duct.

■ **AND**

- The unit is designed to function as soon as power is supplied, however, a warm up for 10 minutes is required for satisfying complete performance described in the data sheet.

COMPONENT IDENTIFICATION

■ FRONT VIEW (When the cover is opened)

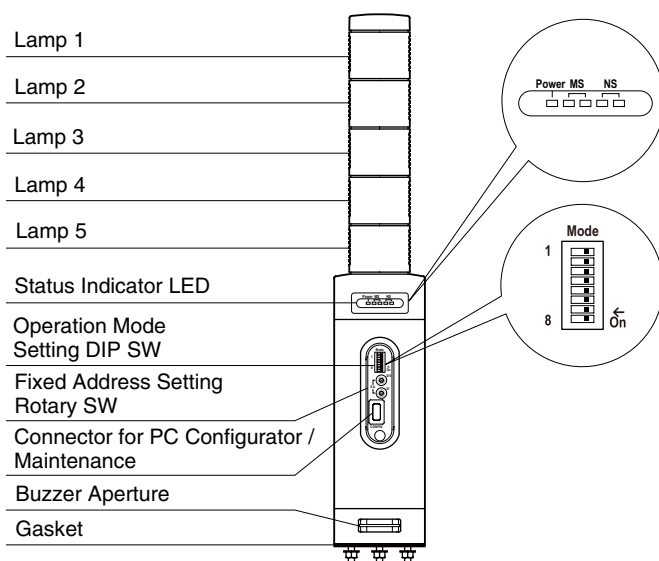

■ STATUS INDICATOR LED

ID	STATUS	COLOR	FUNCTION
Power	ON	Green	The internal power is supplied normally.
MS	ON	Green	Operating in a normal condition
	Blinking	Red	Duplicated IP address, Internal data error
NS	ON	Green	Link on-line and connections in the established state
	Blinking		Link on-line but no connections in the established state
	ON	Red	Duplicated IP address
	Blinking	Red	Communication timeout

■ OPERATING MODE

(*) Factory setting

• Lamp Blinking Frequency: Mode-1

SW1-1	LAMP BLINKING FREQUENCY
OFF	Approx. 2 Hz (*)
ON	Approx. 10 Hz

• Buzzer Intermittent Frequency: Mode-2

SW1-2	BUZZER INTERMITTENT FREQUENCY
OFF	Approx. 2 Hz (*)
ON	Approx. 10 Hz

• Buzzer Volume: Mode-3, Mode-4

SW1-3	SW1-4	BUZZER VOLUME
OFF	OFF	Quiet (*)
OFF	ON	Middle
ON	OFF	Loud
ON	ON	Maximum

• Output at the Loss of Communication: Mode-6

SW1-6	OUTPUT AT THE LOSS OF COMMUNICATION
OFF	Reset the output (turned off) (*)
ON	Hold the output (maintains the last data received normally)

Note: Be sure to set unused SW1-5, 7 and 8 to OFF.

■ IP ADDRESS

Set the host address (2-digit hexadecimal number) in the IP address using rotary switches SA1 and SA2 for the first digit and the second digit, respectively.

When using the host address in the IP address set on the PC configurator software (model: ITCFG), set the switches to '00H'.

When the network address, Subnet Mask, and Default Gateway need to be changed, do so on ITCFG.

(Setting range: 00H – FFH)

(Factory setting: 00H)



IP Address Host Address LSD (x16)



IP Address Host Address MSD (x1)

TERMINAL CONNECTIONS

Connect the unit as in the diagram below.

EXTERNAL DIMENSIONS unit: mm

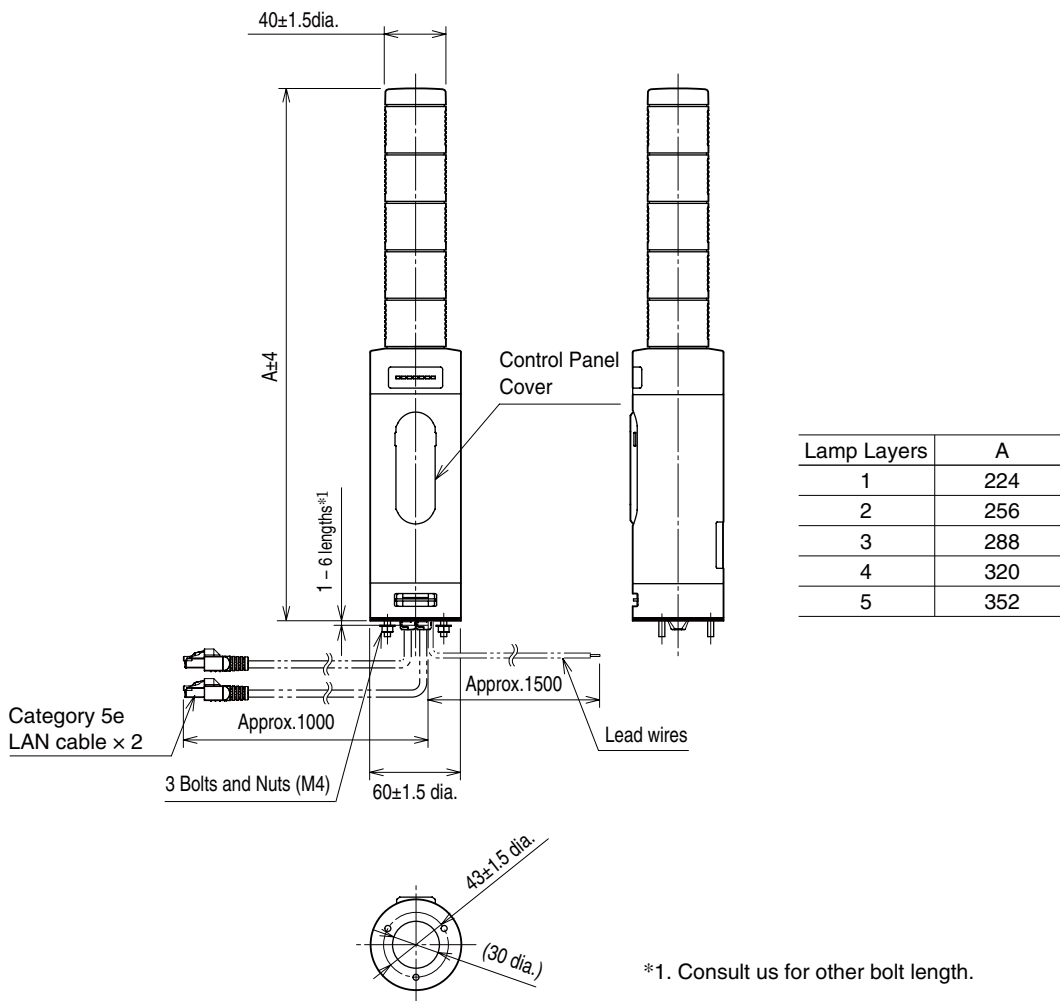

*1. Consult us for other bolt length.

CONNECTION DIAGRAM

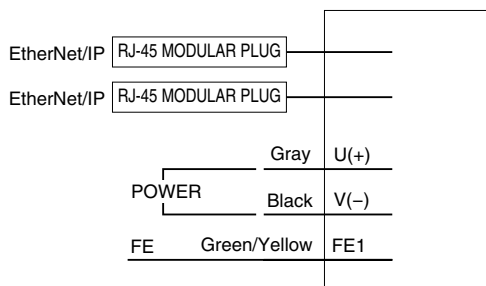

MOUNTING REQUIREMENTS unit: mm

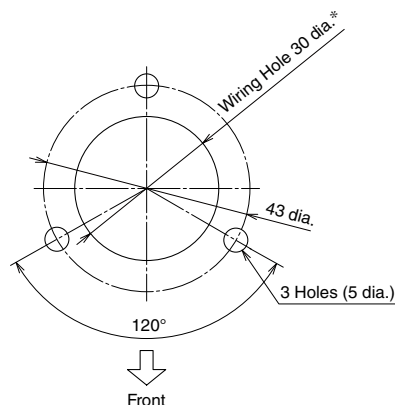

* Protect wires to prevent scratching them at the edge of the compartment.

PC CONFIGURATOR

The following parameter items can be configured with the PC configurator software (model: ITCFG). Refer to the users manual of the software for detailed operations.

■ ETHERNET SETTING

PARAMETER	SETTING RANGE	DEFAULT SETTING
IP Address	0.0.0.0 – 255.255.255.255	192.168.0.250
Subnet Mask	0.0.0.0 – 255.255.255.255	255.255.255.0
Default Gateway	0.0.0.0 – 255.255.255.255	192.168.0.1
LED timeout	0.0 – 3200.0 (sec.)	3.0 (sec.)

CHECKING ETHERNET/IP CONNECTION

■ IP ADDRESS

Set the host address in the IP address using the front rotary switches.

When using the host address in the IP address set on the PC configurator software (model:ITCFG), set the switches to '00H'. When the network address, Subnet Mask, and Default Gateway need to be changed, do so on ITCFG.

■ CHECK TOWER LIGHT CONNECTION

Enter “ping command” on the character user interface (CUI) such as Windows PowerShell or command prompt:

```
C:\WINDOWS>ping ***.***.***.***
```

```
(***.***.***.***; Enter IP address in decimal.)
```

```
ping ***.***.***.*** with 32 bytes of data:
```

```
Reply from ***.***.***.*** : bytes = 32 time < 10ms TTL = 64
```

```
Reply from ***.***.***.*** : bytes = 32 time < 10ms TTL = 64
```

```
Reply from ***.***.***.*** : bytes = 32 time < 10ms TTL = 64
```

```
Reply from ***.***.***.*** : bytes = 32 time < 10ms TTL = 64
```

```
Ping statistics for ***.***.***.***
```

```
Packets: Sent = 4, Received = 4, Lost = 0 (0% loss)
```

Replies in case of normal connection are as shown above. If the connection cannot be established normally due to e.g. wrong IP address, other replies such as 'timeout' will be received.

■ CHECK CONNECTION TO THE APPLICATION SOFTWARE

Check Point: MS/NS indicator

A green light turns on at the MS/NS indicator when data is sent/received normally with the application software.

I/O DATA DESCRIPTIONS

■ INPUT DATA (RESERVED AREA DATA)

Fixed at 0.

■ OUTPUT DATA

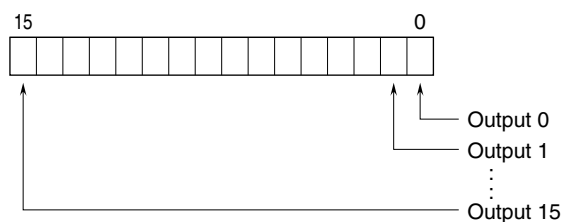

Output 0	Lamp 1	0: Off, 1: On
Output 1	Lamp 2	0: Off, 1: On
Output 2	Lamp 3	0: Off, 1: On
Output 3	Lamp 4	0: Off, 1: On
Output 4	Lamp 5	0: Off, 1: On
Output 5	Buzzer	0: Off, 1: Continuous
Output 6		
Output 7		
Output 8	Lamp 1	0: Off, 1: Blinking
Output 9	Lamp 2	0: Off, 1: Blinking
Output 10	Lamp 3	0: Off, 1: Blinking
Output 11	Lamp 4	0: Off, 1: Blinking
Output 12	Lamp 5	0: Off, 1: Blinking
Output 13	Buzzer	0: Off, 1: Intermittent
Output 14		
Output 15		

Note: If "On" (Continuous) and "Blinking" (Intermittent) are set simultaneously for a single lamp (buzzer), "Blinking" (Intermittent) is disabled.