

LIGHTNING SURGE PROTECTOR FOR THREE-PHASE POWER SUPPLY	MODEL MAT3
---	-------------------

BEFORE USE

Thank you for choosing us. Before use, please check contents of the package you received as outlined below. If you have any problems or questions with the product, please contact our sales office or representatives.

■ PACKAGE INCLUDES:

Surge protector.....(1)

■ MODEL NO.

Check that the model No. described on the specifications matches the operational line voltage and other specifications as shown in 'PERFORMANCE' hereafter.

■ INSTALLATION / INSTRUCTION MANUAL

This manual describes necessary points of caution when you use this product, installation, and basic maintenance procedure.

LIMITATION APPLICABLE TO MAT3

The MAT3 will protect electronics equipment from damage caused by induced lightning by absorbing most of the surge voltages. However, MAT3 may not be effective against certain extremely high voltages exceeding its discharge current capacity (20 kA @ 8/20 μsec. waveform) caused by a direct or almost direct hit by lightning. The MAT3 must be installed according to this installation / instruction manual.

APPLICATIONS

- Protects electric devices such as isolation transformers, heaters, electromagnetic contactors, motors.
- Protects electric devices of high load current.
- Provides primary protection of a power supply system (L-L, L-N, and N-PE) in a distribution switchboard.

Low-voltage equipment such as computers, measuring instruments, transmission devices, which generally incorporates semiconductor circuitries, is especially vulnerable against lightning surges. We recommend to use combination type surge protectors incorporating serial impedance (model examples: MAX, MMA, MAH), or to set up a double protection by MAT3's (Refer to 'PROTECTING LOW-VOLTAGE EQUIPMENT' under 'WIRING' section).

PERFORMANCE

MODEL	Uc (AC) (V)	DISCHARGE VOLTAGE (Vmin)	Up (Vmax)	OPERATIONAL VOLTAGE RANGE *1 (50 / 60 Hz)
MAT3-240	240	Between lines: 400 V N to PE: 680 V	1500	1-phase/2-wire, 3-phase/3-wire: 90 – 240 V AC 1-phase/3-wire: 90 / 180 – 120 / 240 V AC 3-phase/4-wire: 170 – 240 V AC

Uc = Maximum continuous operational voltage

Up = Voltage protection level

*1. MAT3 is operational as an SPD despite the voltage less than the minimum. However, the functions of the monitor LED and the alarm output are not guaranteed.

MODEL	MAX. LEAKAGE CURRENT @Uc			
	ALARM OUTPUT	WITH	WITHOUT	
MAT3-240	Line to Line	1 to 2	28 mA *2	6 mA *3
		Other sections	2 mA	2 mA
		N to PE	10 μA	10 μA

*2. Approx. 12 mA @100 V AC

*3. Approx. 3 mA @100 V AC

Discharge current:

MODEL	MAX. DISCHARGE CURRENT (Imax)	NOMINAL DISCHARGE CURRENT (In)
MAT3-240xMx	20 kA (8/20 μsec.)	10kA (8/20 μsec.)

Response time: ≤ 4 nsec. (≤ 20 nsec. for N to PE)

Insulation resistance: ≥ 100 MΩ with 500 V DC (line to alarm output)

Dielectric strength: 2000 V AC @1 minute (line to alarm output)

POINTS OF CAUTION

■ INSTALLATION

• DANGER!

The MAT3 is classified as IEC 61643-11 (EN 61643-11) Class II; DO NOT install the MAT3 at the point common to an external lightning protection device such as a lightning rod. The MAT3 will be subject to the danger of direct lightning.

• DANGER!

DO NOT perform an installation and wiring of the MAT3 during thunder storms.

- Indoor use.
- Be sure to house the MAT3 inside a metal enclosure for safety. Even though the MAT3 is capable of withstanding an induced discharge current expected in normal conditions, it is entirely possible to be hit by a certain strong lightning exceeding its designed capacity. It is also subject to a direct hit by a lightning. The MAT3 will be destroyed by such high lightning energy.
- We recommend to install the MAT3 in a position where the monitor LED is clearly visible to facilitate inspection and maintenance.
- DO NOT install the MAT3 where it is subjected to continuous vibration. Do not apply physical impact to the MAT3.
- Environmental temperature must be within -5 to +55°C (23 to 131°F) and relative humidity within 5 to 95% RH in order to ensure adequate life span and operation.

■ HIGH TEMPERATURE

• DANGER!

The front parts of the surface may be hot. DO NOT grab the sides of the module. When the MAT3's discharge element (zinc oxide element) gradually degrades, its increased leakage current causes high temperature at the surface of the MAT3, until the discharge element is finally separated from the power line by the thermal breaker. However, a part of the module may already be too hot to touch safely if the module is near the end of its life.

■ OPERATIONAL VOLTAGE

- DO NOT connect a power source of which the nominal operational voltage exceeds the MAT3's maximum continuous operational voltage, U_c value indicated on the specification label at the front.
- Be sure that the peak voltage does not exceed 1.4 times the maximum continuous operational voltage. Distorted waveform may have extremely high peak voltage.

■ DIELECTRIC STRENGTH TESTING

- Conduct the dielectric strength test with all power supply wires removed. The MAT3 will start discharging at the described discharge voltage if a test voltage is applied with all power supply wires connected. It will result in an insulation failure.

■ TERMINAL COVER

- DO NOT remove the terminal cover as it is open/close type.

■ AND....

- We recommend that you keep spare MAT3's so that you can replace them quickly when necessary.

FEATURES

■ CURRENT CAPACITY

- The one-port SPD can be used regardless of the load current.

■ HIGH PERFORMANCE & RESPONSE TIME

- The discharge element (zinc oxide varistor) between the lines does not disturb the power line with follow current normally observed by a spark gap after a discharge. The response time is also very high.

■ HIGH DISCHARGE CURRENT CAPACITY

- The MAT3 is designed to withstand 20 kA surges (test waveform 8/20 μ sec.). High design standard compared to normally induced surge current level of 1 kA.

■ THERMAL BREAKER

- The power supply voltage is continuously applied to the incorporated discharge element (zinc oxide element). Degraded element is automatically separated from the power lines for safety to prevent overheating caused by leakage current.
- The failure is notified visually by the monitor LED and remotely by an alarm contact.

■ PREVENTING ELECTRIC SHOCK

- The MAT3's terminal section with a terminal cover has IP20 protection level to protect from an electric shock.
- The MAT3 is designed for use with ring shape solderless terminals for a wide range of wire sizes from 2 to 14 mm².

SCHEMATIC CIRCUITRY

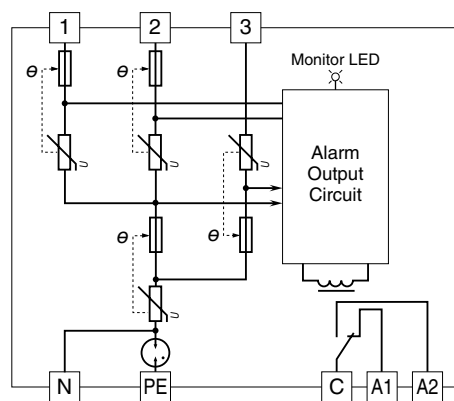

θ : Thermal breaker

Note: Terminals C, A1 & A2 are available for 'Alarm output' code 'A.'
The schematic shows the relay contact status of a thermal trip or power off.

INSTALLATION

■ DIN RAIL MOUNTING

The MAT3 is mounted on a 35-mm-wide DIN rail. Set the MAT3 so that its DIN rail adaptor is at the bottom. Position the upper hook at the rear side of base on the DIN rail and push in the lower.

When removing, push down the DIN rail adaptor utilizing a minus screwdriver while avoiding a wiring to PE terminal and pull.

CONNECTION PROCEDURE

■ INSTALLING CIRCUIT BREAKERS

The MAT3 incorporates a thermal breaker which separates the discharge element from the power line upon detecting the increased leakage current by the element's gradual degradation.

However, in rare cases, when the MAT3 is hit by an extremely strong lightning which exceeds the MAT3's designed induced surge capacity, the discharge element may be burned out and short-circuited at a burst without the thermal breaker being able to separate it safely from the line.

Install a circuit breaker at the power source side of the surge protector as a backup protection. The example below shows a three-phase/4-wire configuration. Molded-case circuit breakers (MCCB), residual current circuit breaker (RCD) or current-limiting fuses (slow-blow type only) can be used.

■ INSTALLATION EXAMPLES: Three-phase 4-wire connection

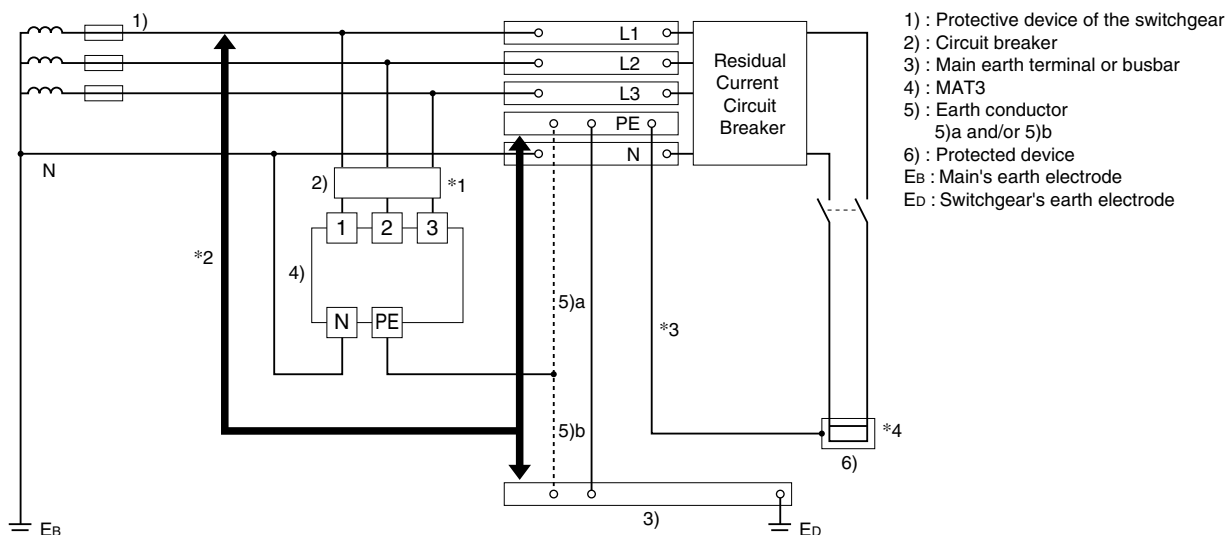

*1. The circuit breaker or the fuse as disconnectors must be installed.

Molded-case circuit breaker (MCCB) or residual current circuit breaker with overcurrent protection (RCD) can be used.

The rated interrupting capacity of the circuit breaker must be greater than the highest amount of current that could be available in the circuit.

Install MCCB (rated current 20 – 30A) that has element for each phase.

Or RCD with protection from nuisance tripping against transit voltages type or time-delay overcurrent protection type is recommended.

Recommended sensitivity current rating: 30mA

*2. Cable length between the branch point and the earthing: 0.5 meters or less recommended

*3. The protected device's metal enclosure must be cross-wired to the earth terminal of the MAT3. If the protected device has no earth terminal, earth only the MAT3.

*4. In order to protect an electronic circuit such as measuring equipment or communication equipment, we recommend to use surge protectors which have serial impedance incorporated such as our models MAX, MMA, MAH.

■ USING AN EARTH LEAKAGE CIRCUIT BREAKER

RCD with protection from nuisance tripping against transit voltages type or time-delay overcurrent protection type is recommended for use with surge protectors.

■ DISCONNECTORS REQUIREMENTS

Additional requirements are listed below:

- When the alarm output of the MAT3 should be used, choose also a circuit breaker with an alarm output. Configure a logical addition sequence so that the alarm trips when both or either of the MAT3 or the breaker alarm trips.
- Recommended rating of a current-limiting fuse: Rated current 30 A, I^2t value 5000 A²s minimum. Be sure that current-limiting fuses have no alarm and thus visual inspection is required when the MAT3 is with the alarm output.

■ CONNECTION EXAMPLES BY POWER SYSTEMS

For circuit breakers in the figures, refer to 'DISCONNECTORS REQUIREMENTS'

Abnormal voltages appearing in case of a light load or a ground loop must be within the maximum continuous operational voltage when selecting the MAT3 models.

POWER SYSTEM	Single-phase/2-wire		Three phase/3-wire (delta connection)	
CONNECTION				
EXAMPLE	Power System (example)	SPD1	Power System (example)	SPD1
	Single-phase/2-wire 110V AC Single-phase/2-wire 220V AC	MAT3-240xMx MAT3-240xMx	Three-phase/3-wire 220V AC	MAT3-240xMx
POWER SYSTEM	Single-phase/2-wire (three-phase delta connection earthed in the middle of phases) Single-phase/3-wire		Three-phase/4-wire (star connection)	
CONNECTION				
EXAMPLE	Power System (example)	SPD1	Power System (example)	SPD1
	Single-phase/2-wire 110V AC Single-phase/3-wire 220/110V AC	MAT3-240xMx MAT3-240xMx	Three-phase/4-wire 220V AC	MAT3-240Mx

*1. For TT system, in order to ensure safe failure mode at TOV due to earth fault on high-voltage systems, connect between terminal 2 and N of the MAT3.

*2. For TT system, in order to ensure safe failure mode at TOV due to earth fault on high-voltage systems, install a four-pole (three-pole plus neutral) circuit breaker.

*3. For single-phase/2-wire system, connect lines to terminal 1 and 2 of the MAT3. For single-phase/3-wire system, connect the neutral line to terminal 2 of the MAT3.

WIRING

LEADWIRES

Conductor cross-section area: 5.5 mm² minimum for both the power and the ground lines. However, a local industrial standard requirement for wiring should take precedence.

SOLDERLESS TERMINAL

Applicable ring tongue terminal without insulation sleeve is as indicated below. Spade tongue terminal must conform with the ring type size.

In order to ensure IP20 protection (IEC 60529) with a solderless terminal, cover the terminal with a insulation cap to prevent direct touching by a hand.

Applicable Solderless Terminal Size

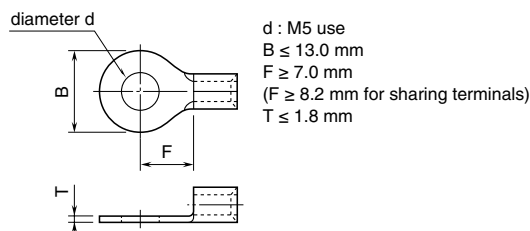

TORQUE

Tighten the screw terminals securely. Maximum allowable torque is of 2.5 N·m.

WIRE LENGTH

Keep the wire length to the minimum for both the power source side and the ground side. An example with single-phase/two-wire configuration is shown below. The wire length between the branch point and the ground ('a' in the figure) should ideally be less than 0.5 meters. Extra long wires should not be bundled in coils, but be cut to the minimum required length.

PROTECTING LOW-VOLTAGE EQUIPMENT

The MAT3, one-port surge protector, is most suitable to protect electric devices such as isolation transformers, heaters, electromagnetic contactors, motors. On the other hand, combination type surge protectors incorporating serial impedance (model examples: MAX, MMA, MAH) are suitable to protect low-voltage electric devices such as computers, measuring instruments, transmission devices.

However, when the distance between the distribution switchboard and the protected device ('b' in the figure) is longer than 20 or 30 meters, the reactance of the wires would function as serial impedance in the combination type surge protectors.

In this case, the overall protection performance should be augmented by one-port surge protectors installed inside the switchboard and next to the protected device, protected device side cross-wired to the ground.

Single-Phase/2-wire connection

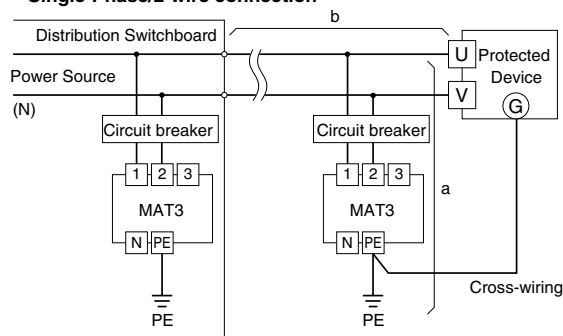

GROUNDING

COMMON GROUNDING WITH CROSS-OVER WIRE

Basically a common grounding with cross-wiring between the MAT3 and the protected device is recommended for adequate protection. Grounding resistance should be less than 100 ohms. If the protected device has no ground terminal, ground only the MAT3.

The ground point should be close to the MAT3 side as shown below.

Single-Phase/2-wire connection

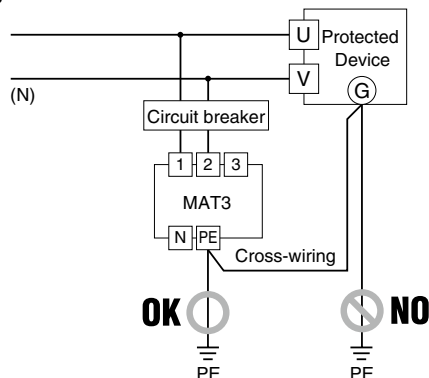

INDEPENDENT GROUNDING

The MAT3 installed inside a distribution switchboard is often located far from the protected device, thus an independent grounding is needed. In such cases, keep the grounding resistance as low as possible (several ohms), or add another MAT3 for local protection next to the protected device.

ALARM OUTPUT

Optional SPDT relay output is available to alert when the thermal breaker has separated the discharge element from the power supply circuit.

If the alarm output should be transmitted remotely via outdoor cables, a surge protector for signal line is required.

Choose a circuit breaker with an alarm output. Configure a logical addition sequence so that the alarm trips when both or either of the MAT3 or the breaker alarm trips.

RELAY SPECIFICATIONS

Alarm output: The SPDT relay trips when the thermal breaker operates and/or power source shut-down.

Rated load: 250 V AC @1 A (resistive load)
24 V DC @1 A (resistive load)

CONNECTION

Terminal: Tension clamp

Applicable wire size: 0.13 to 1.5 mm²

Stripped length: 8 mm

CHECKING

WIRING

- Make sure that wiring is done as instructed in the connection diagram.
- Make sure that the Ground terminal (G) is connected to the metallic housing of protected equipment.
- Make sure that the Ground terminal (G) is grounded to earth.

MAINTENANCE

Even lightning in remote locations could induce surges without our knowledge. Regular checking of the surge protector is important to find degradations in early stage, before and after the storm seasons, and whenever you experience a strong lightning storm.

DO NOT attempt checking or replacing the surge protector during a thunder storm for safety.

Checking procedure is as explained below:

■ CHECK EXTERIOR

If discoloration or deformation is observed, replace with a new one immediately.

■ CHECK MONITOR LED

Green LED turns on during normal operation, indicating the surge protector is functioning properly. Turning off means that the protector is in failure. Replace with a new one immediately.

■ CHECK WITH A INSULATION TESTER

Confirm conduction across the same terminals with a 500 V DC 1000 MΩ insulation tester. If the tester shows 20 MΩ or less, the protector is in failure. Replace with a new one immediately.

EXTERNAL DIMENSIONS & TERMINAL ASSIGNMENT

Unit: mm (inch)

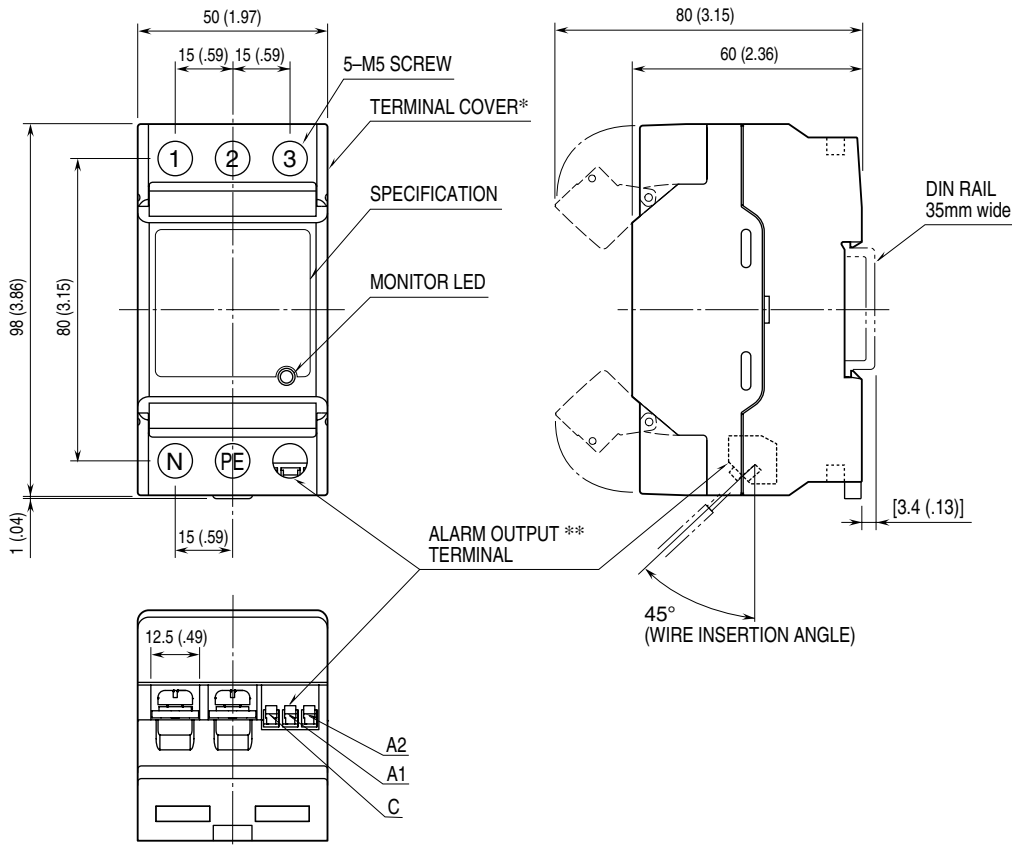

* Open/close type.

** Only for 'Alarm output' code 'A'.