

**LIGHTNING SURGE PROTECTOR FOR
ANALOG TELECOM LINE USE (life monitor)**

MODEL **MDA-TL**

BEFORE USE

Thank you for choosing us. Before use, please check contents of the package you received as outlined below. If you have any problems or questions with the product, please contact our sales office or representatives.

■ PACKAGE INCLUDES:

Lightning surge protector (body + base socket).....(1)

■ MODEL NO.

Confirm Model No. marking on the product to be exactly what you ordered.

■ INSTRUCTION MANUAL

This manual describes necessary points of caution when you use this product, including installation, connection and basic maintenance procedures.

LIMITATION APPLICABLE TO M-RESTER

The M-RESTER will protect electronics equipment from damage caused by lightning by absorbing most of the surge voltages.

However, M-RESTER may not be effective against certain extremely high voltages caused by a direct or almost direct hit by lightning.

M-RESTER must be installed according to this installation/ instruction manual.

GENERAL

■ FUNCTION & FEATURES

- Designed specifically to protect telecommunication equipment from lightning surges entering through telecommunication line network

■ SPECIFICATIONS

	Btwn Lines	Line to Gnd
Discharge voltage	±190V min.	±180V min.
Max. surge voltage*	±500V max.	±900V max.
Leakage current	≤ 100µA @±160V DC	≤ 100µA @±160V DC
Response time	≤ 0.01 µsec.	
Discharge current capacity	500A (8 / 20 µsec.)	
Modular jack connection	10000A (8 / 20 µsec.)	
Screw terminal connection		
Max. load current	200mA	
Internal series resistance	Approx. ≤ 4Ω including return	
Frequency band	Approx. 100 kHz/-3 dB at 600Ω terminating resistance	
Max. line voltage	±160V DC	

*The maximum voltage that could pass through M-RESTER. Protected equipment must be able to withstand this voltage for a very short time period.

POINTS OF CAUTION

■ POWER INPUT RATING & OPERATIONAL RANGE

- Locate the power input rating marked on the product and confirm its operational range as indicated below:
AC power: 85 – 264V, 47 – 66 Hz, approx. 2 – 4VA
DC power: 24V ±10% or 85 – 150V, approx. 1.5W

■ GENERAL PRECAUTIONS

- Before you remove the unit from its base socket or mount it, turn off the power supply and the signal for safety.

■ ENVIRONMENT

- Indoor use.
- When heavy dust or metal particles are present in the air, install the surge protector inside proper housing with sufficient ventilation.
- Do not install the surge protector where it is subjected to continuous vibration. Do not subject the unit to physical impact.
- Environmental temperature must be within -5 to +55°C (23 to 131°F) with relative humidity within 30 to 90% RH in order to ensure adequate life span and operation.
- Be sure that the ventilation slits are not covered with cables, etc.

■ WIRING

- Do not install cables close to noise sources (relay drive cable, high frequency line, etc.).
- Do not bind these cables together with those in which noises are present. Do not install them in the same duct.

■ AND

- The unit is designed to function as soon as power is supplied, however, a warm up for 10 minutes is required for satisfying complete performance described in the data sheet.

COMPONENT IDENTIFICATION

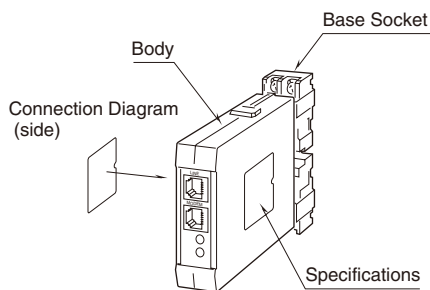

FRONT PANEL

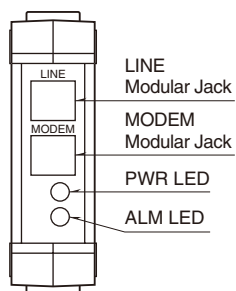

PWR LED (green)

The green LED turns on while the power is supplied. The LED turns off and the alarm output is turned on when the power supply is removed.

ALM LED

The tricolor LED turns off, then on in green, amber, and red according to the unit status.

- 1) Remains OFF when the power supply is first turned on.
- 2) Green: The unit has received one or more surges. (The LED does not turn on when the power is not supplied.)
- 3) Amber: Replacement is recommended.
- 4) Red: The life span has ended. Replace the unit immediately. The alarm output is turned on.

INSTALLATION

Pull out the body in pressing the clamps located at the top and bottom of the unit to separate it from the base socket.

DIN RAIL MOUNTING

Set the base socket so that its DIN rail adaptor is at the bottom. Hang the upper hook at the rear side of base socket on the DIN rail and push in the lower. When removing the socket, push down the DIN rail adaptor utilizing a minus screwdriver and pull.

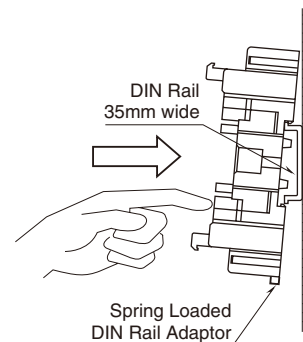

WALL MOUNTING

Refer to "EXTERNAL DIMENSIONS."

TERMINAL CONNECTION

Connect the unit as in the diagram below or refer to the connection diagram on the side of the unit. Be sure to make cross-wiring as shown in "GROUNDING". If the protected equipment is not provided with a G terminal, ground only this unit's G terminal.

EXTERNAL DIMENSIONS unit: mm [inch]

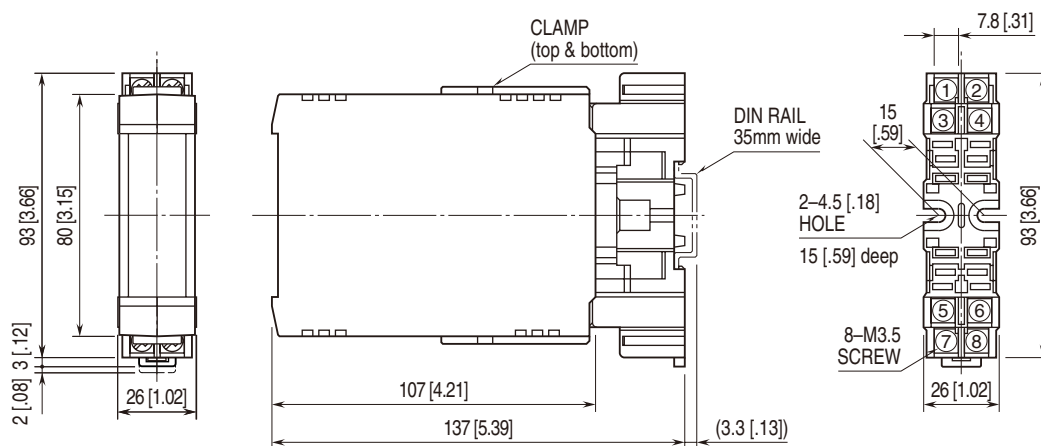

•When mounting, no extra space is needed between units.

■ CONNECTION DIAGRAM

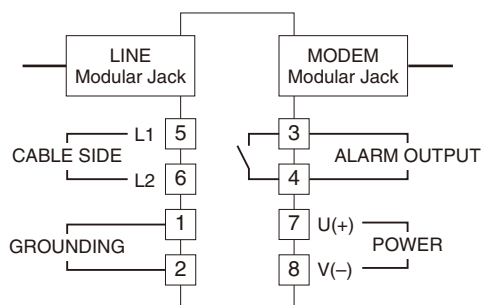

■ GROUNDING

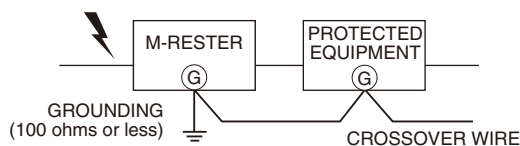

A crossover wire between M-RESTER ground and ground or metallic housing of equipment is required for protection.
If the protected equipment has no ground terminal, ground the M-RESTER only.

MAINTENANCE

While the ALM LED is green, regular inspections are recommended.

When it turns amber, replacement of the unit is recommended.

When it turns and remains red, replace the unit immediately.

CAUTION !

Before replacing the unit, make sure to turn off the power supply for safety. Other factors such like an alarm system connected to the line should also be considered.

The life monitoring circuit remains alive by the internal backup circuit even when the external power supply is removed. The LED is turned off in that case. The backup power is normally effective for approximately one week depending upon environmental conditions.

CHECKING

■ WIRING

- 1) Make sure that wiring is done as instructed in the connection diagram.
- 2) Power input: Check voltage across the terminal 7 – 8 with a multimeter.
- 3) Make sure that Ground terminal 1 is connected to the metallic housing of protected equipment.
- 4) Make sure that Ground terminal 1 is grounded to earth.

■ ELEMENT MODULE

- 1) Shortcircuit: Check resistance across the following terminals on the high-resistance range of multimeter ($\geq 100M\Omega$ or infinite standard).
Terminals (L1) – (L2), (L1) – (G), (L2) – (G)
- 2) Discharging: Check that discharging occurs across the same terminals with a 500V DC megger (Indicator of the megger must show $\leq 20M\Omega$).