

**VALVE POSITIONER**  
(current feedback; built-in SSR)

MODEL **MEX-D**

**BEFORE USE ....**

Thank you for choosing us. Before use, please check contents of the package you received as outlined below. If you have any problems or questions with the product, please contact our sales office or representatives.

■ **PACKAGE INCLUDES:**

Valve positioner (body + base socket).....(1)

■ **MODEL NO.**

Confirm Model No. marking on the product to be exactly what you ordered.

■ **INSTRUCTION MANUAL**

This manual describes necessary points of caution when you use this product, including installation, connection and basic maintenance procedures.

**POINTS OF CAUTION**

■ **POWER INPUT RATING & OPERATIONAL RANGE**

- Locate the power input rating marked on the product and confirm its operational range as indicated below:  
**AC power:** Rating  $\pm 10\%$ , 50/60  $\pm 2$  Hz, approx. 3VA

■ **GENERAL PRECAUTIONS**

- Before you remove the unit from its base socket or mount it, turn off the power supply and power to a motor for safety.

■ **ENVIRONMENT**

- Indoor use.
- When heavy dust or metal particles are present in the air, install the unit inside proper housing with sufficient ventilation.
- Do not install the unit where it is subjected to continuous vibration. Do not subject the unit to physical impact.
- Environmental temperature must be within  $-5$  to  $+60^{\circ}\text{C}$  ( $23$  to  $140^{\circ}\text{F}$ ) with relative humidity within 30 to 90% RH in order to ensure adequate life span and operation.

■ **WIRING**

- Do not install cables close to noise sources (relay drive cable, high frequency line, etc.).
- Do not bind these cables together with those in which noises are present. Do not install them in the same duct.

■ **MOTOR**

- The internal SSR is not designed to direct-reverse driving for a 200V AC motor.

■ **AND ....**

- The unit is designed to function as soon as power is supplied, however, a warm up for 10 minutes is required for satisfying complete performance described in the data sheet.

**COMPONENT IDENTIFICATION**

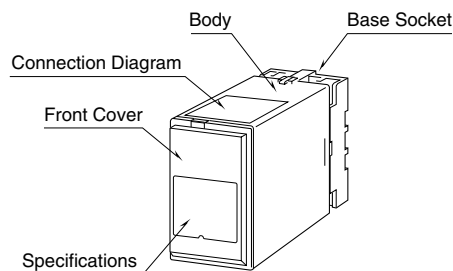

■ **HOW TO OPEN THE FRONT COVER:**

Hang your finger on the hook at the top of the front cover and pull.

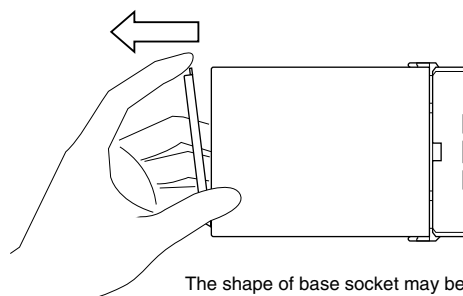

The shape of base socket may be different for some models.

■ **FRONT PANEL CONFIGURATIONS**

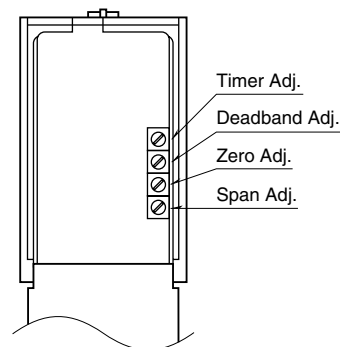

## INSTALLATION

Detach the yellow clamps located at the top and bottom of the unit for separate the body from the base socket.

### ■ DIN RAIL MOUNTING

Set the base socket so that its DIN rail adaptor is at the bottom. Hang the upper hook at the rear side of base socket on the DIN rail and push in the lower. When removing the socket, push down the DIN rail adaptor utilizing a minus screwdriver and pull.

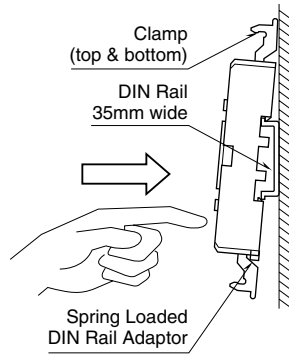

### ■ WALL MOUNTING

Refer to "EXTERNAL DIMENSIONS."

Shape and size of the base socket are slightly different with various socket types.

## TERMINAL CONNECTIONS

Connect the unit as in the diagram below or refer to the connection diagram on the top of the unit.

### ■ EXTERNAL DIMENSIONS unit: mm (inch)

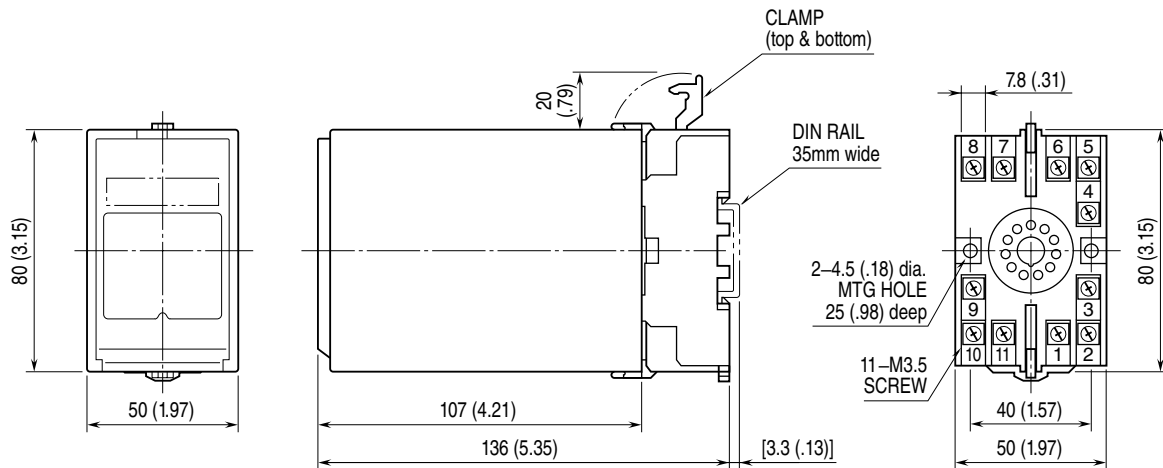

• When mounting, no extra space is needed between units.

### ■ CONNECTION DIAGRAM

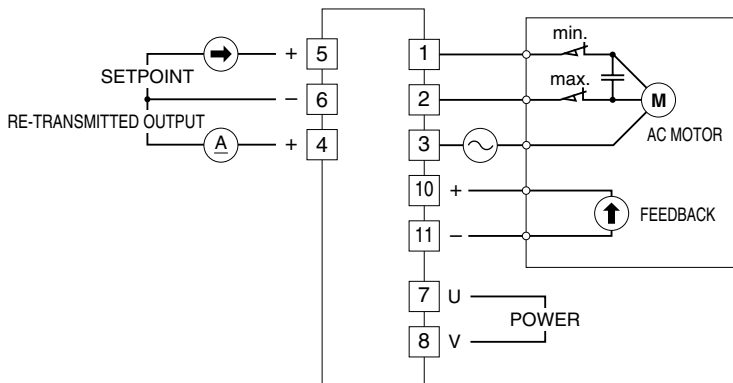

## CHECKING

- 1) Terminal wiring: Check that all cables are correctly connected according to the connection diagram.
- 2) Power input voltage: Check voltage across the terminal 7 – 8 with a multimeter.
- 3) Input: Check voltage across the terminal 5 (+) – 6 (–) to show within 0.4 to 2V.
- 4) Feedback signal: Check voltage across the terminal 10 – 11 to show within 80 to 400mV.
- 5) Output: Check voltage across the output terminals.

### Output Operation

POWER	ON			OFF
OUT. TERM.	SET < POS	SET = POS	SET > POS	–
1 – 3	OFF	OFF	ON	OFF
2 – 3	ON	OFF	OFF	OFF

ON:  $\leq 2V$  AC across the output terminals

OFF: 60 – 280V AC across the output terminals

When deviation between the setpoint and the position is narrower than deadband, the output terminals show the status equal to 'SET = POS.'

## ADJUSTMENTS

### ■ CONNECTING TO THE MOTOR

The motor must be connected carefully considering the relation between the motor's rotating direction and the feedback signal. If the connection is inappropriate, the MEX-D, upon startup, drives the motor until it hits either end of span with no control capability in midspan.

### ■ DEADBAND

The deadband is factory set to the maximum value (20%). Turn the adjustment counterclockwise until hunting stops. Adjustable within 2 to 20%.

### ■ MOTOR POSITIONING

#### 0% Position

Apply 0% setpoint signal and adjust the 0% output position with Zero Adjustment. Adjustable within 0 to 25%.

#### 100% Position

Apply 100% setpoint signal and adjust the 100% output position with Span Adjustment. Adjustable within 75 to 100%.

### ■ TIMER

Set minimum interval for open/close operation, used for protecting control motor from too frequent open/close operation. Adjustable to 1 – 30 seconds.

Deadband adjustment can realize similar effects. Combine these two functions according to the control loop characteristics to minimize the motor's operation and prevent it from overheating and wearing unnecessarily.

## MAINTENANCE

Regular calibration procedure is explained below:

### ■ CALIBRATION

Confirm the motor position at 0%, 50% and 100% input signals.

## LIGHTNING SURGE PROTECTION

We offer a series of lightning surge protector for protection against induced lightning surges. Please contact us to choose appropriate models.