

LIGHTNING SURGE PROTECTOR FOR STANDARD SIGNAL LINE USE (high discharge current capacity)	MODEL	MMD
---	-------	------------

BEFORE USE

Thank you for choosing us. Before use, please check contents of the package you received as outlined below. If you have any problems or questions with the product, please contact our sales office or representatives.

■ PACKAGE INCLUDES:

Lightning surge protector.....(1)

■ MODEL NO.

Confirm Model No. marking on the product to be exactly what you ordered.

■ INSTALLATION / INSTRUCTION MANUAL

This manual describes necessary points of caution when you use this product, including installation, and basic maintenance procedure.

LIMITATION APPLICABLE TO M-RESTER

The M-RESTER will protect electronics equipment from damage caused by lightning by absorbing most of the surge voltages.

However, M-RESTER may not be effective against certain extremely high voltages caused by a direct or almost direct hit by lightning.

M-RESTER must be installed according to this installation / instruction manual.

GENERAL

■ FUNCTION & FEATURES

- Designed specifically for 4 – 20mA DC line including both 4-wire and 2-wire transmitters
- Discharge current capacity 10000A
- Absorbs surges only without affecting instrumentation signal

■ SPECIFICATIONS

	BETWEEN LINES	LINE TO GND
Discharge voltage	±40V min.	±290V min.
Max. surge voltage*	±50V max.	±800V max.
Leakage current	≤5µA @±30V DC	≤5µA @±140V DC
Response time	0.01 µsec.	
Discharge current	10000A (8 / 20 µsec.)	
Maximum load current	0.1A	
Internal series resistance	≤0.4Ω including return	
Maximum line voltage	±30V	

*The maximum voltage that could pass through M-RESTER. Protected equipment must be able to withstand this voltage for a very short time period.

POINTS OF CAUTION

■ ENVIRONMENT

- When heavy dust or metal particles are present in the atmosphere, install M-RESTER inside proper housing and ventilate it.
- Do not install the M-RESTER where it is subjected to continuous vibration. Do not apply physical impact to the M-RESTER.
- Environmental temperature must be within -5 to +55°C in order to ensure adequate life span and operation.

■ WIRING

- The discharge element incorporated in the M-RESTER is grounded to its housing. Therefore, DO NOT do an insulation test. If you do, the element will start discharging between line and ground at the discharge voltage value.

■ RATED CURRENT

- Be sure that the rated current of protected equipment does not exceed the maximum load current specification of the M-RESTER.

■ AND

- We recommend that you keep spare M-RESTERS so that you can replace them when necessary.

COMPONENT IDENTIFICATION

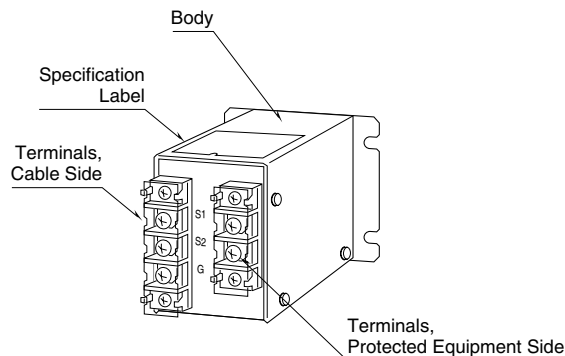

■ FRONT PANEL CONFIGURATION

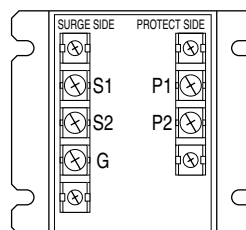

INSTALLATION

Refer to the drawings below.

EXTERNAL DIMENSIONS unit: mm (inch)

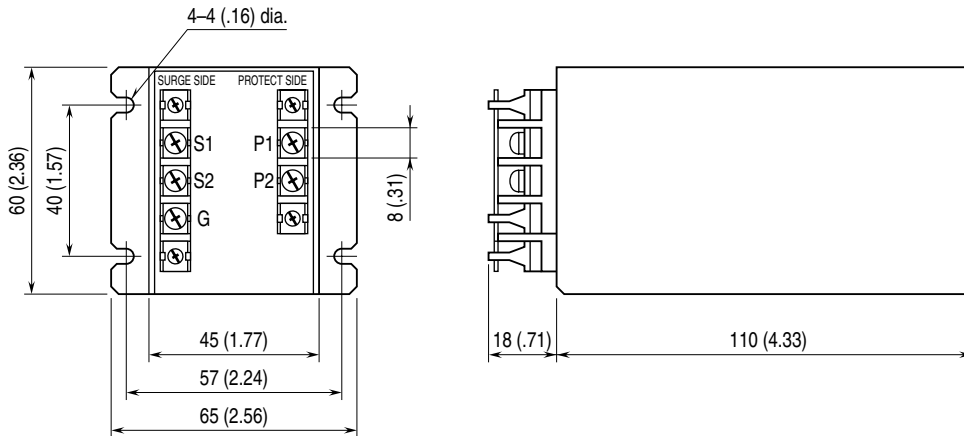

MOUNTING REQUIREMENTS mm (inch)

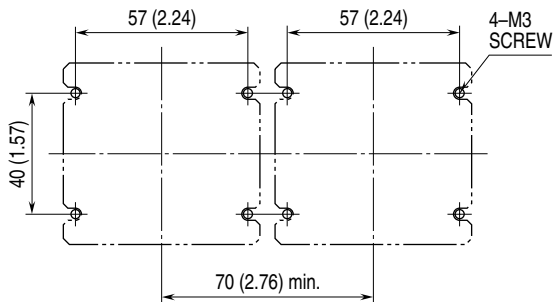

TERMINAL CONNECTIONS

Connect the unit as in the diagram below.

Be sure to cross-wire between the Ground terminal (G) and metallic housing of the protected equipment. (100Ω max.)

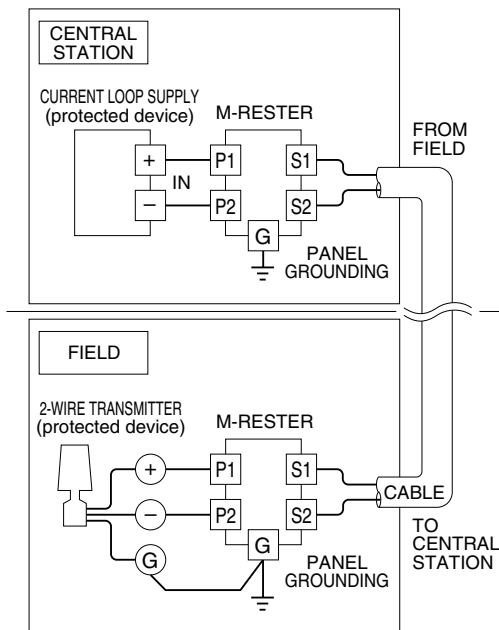

GROUNDING

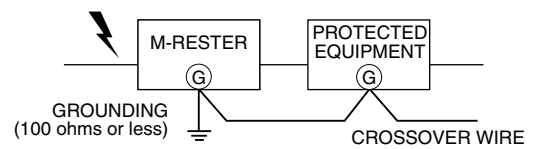

A crossover wire between M-RESTER ground and ground or metallic housing of equipment is required for protection. If the protected equipment has no ground terminal, ground the M-RESTER only.

MAINTENANCE

Check M-RESTER periodically. Many cases of lightning are ignored, and even lightning at a far distance often causes inductive surges.

We recommend that you check your M-RESTER about twice a year, before and after the rainy season. Check whenever you experience a strong lightning occurrence.

Checking procedure is explained in the following:

■ CHECKING WIRING

- Make sure that wiring is done as instructed in the connection diagram.
- Make sure that the Ground terminal (G) is connected to the metallic housing of protected equipment.
- Make sure that the Ground terminal (G) is grounded to earth.

DISCHARGE FUNCTION

Remove all wiring connected to M-RESTER and test its discharge capability as follows:

- Check resistance across the following terminals (infinite standard).
Terminals (S1) – (S2), (S1) – (G), (S2) – (G)
- Check that discharging occurs across the following terminals with a 500V DC megger. (Indicator of the megger reaches over-scale.)
Terminals (S1) – (S2), (S1) – (G), (S2) – (G)
- If any of the above tests shows negative, replace the M-RESTER.