

LIGHTNING SURGE PROTECTOR FOR POWER SUPPLY USE (10 – 30A; replaceable arrester module)	MODEL	MMH
---	-------	------------

BEFORE USE

Thank you for choosing us. Before use, please check contents of the package you received as outlined below. If you have any problems or questions with the product, please contact our sales office or representatives.

■ PACKAGE INCLUDES:

Lightning surge protector
(body + arrester module + power relay)(1)

■ MODEL NO.

Confirm Model No. marking on the product to be exactly what you ordered.

■ INSTALLATION / INSTRUCTION MANUAL

This manual describes necessary points of caution when you use this product, including installation, and basic maintenance procedure.

LIMITATION APPLICABLE TO M-RESTER

The M-RESTER will protect electronics equipment from damage caused by lightning by absorbing most of the surge voltages.

However, M-RESTER may not be effective against certain extremely high voltages caused by a direct or almost direct hit by lightning.

M-RESTER must be installed according to this installation / instruction manual.

GENERAL

■ FUNCTION & FEATURES

The model MMH, designed specifically for power requirements of medium capacities (10 or 30 amps), protects electronic equipment from lightning surges induced through power cables.

Conventional lightning arrester utilizes a fuse to prevent fire when it is damaged by surges far more exceeding its capacity. It shuts the power supply line off, and eventually affects overall plant operations.

The MMH, on the other hand, only separates the damaged arrester module model MEH from the line by driving the power relay.

When a leakage current detected inside the MEH exceeds approx. 100mA, the MMH drives and latches the power relay, which is indicated by closed alarm contact and red ALARM LED on the front.

The alarm contact is reset when the MEH is removed from its socket or when the power is turned off.

When the alarm is indicated, the surge voltage between lines is increased up to 800V. Replace the MEH with a new one as soon as possible.

■ SPECIFICATIONS

	BETWEEN LINES		LINE TO GND
	MMH-1	MMH-2	
Discharge voltage	130V AC min.	285V AC min.	285V AC min.
Max. surge volt. (p-p)*	350V max.	700V max.	800V max.
Leakage current	≤50mA @110V AC	≤30mA @220V AC	≤1mA @220V AC
Response time	≤0.01 μsec.		
Discharge current	10000A (8 / 20 μsec.)		
Max. load current	10A (MMH-x10) or 30A (MMH-x30)		
Voltage drop	≤1V (50/60 Hz)		

*The maximum voltage that could pass through M-RESTER. Protected equipment must be able to withstand this voltage for a very short time period.

POINTS OF CAUTION

■ ENVIRONMENT

- When heavy dust or metal particles are present in the atmosphere, install M-RESTER inside proper housing and ventilate it.
- Do not install the M-RESTER where it is subjected to continuous vibration. Do not apply physical impact to the M-RESTER.
- Environmental temperature must be within -5 to +55°C and humidity within 30 – 90% RH in order to ensure adequate life span and operation.

■ DIELECTRIC STRENGTH TEST

- DO NOT perform dielectric strength tests for the MMH. The arrester module is grounded to the metallic housing inside the unit. The discharge element will start discharging between line and ground when a dielectric strength test is performed.

■ RATED CURRENT

- Be sure that the rated current of protected equipment does not exceed the maximum load current specification of the M-RESTER.
- Be sure to install a breaker which matches the current rating at the power supply side of the M-RESTER.

■ ALARM CONTACT

- During NORMAL operation, it is possible for the ALARM LED to remain OFF and the ALARM contact to turn ON momentarily when experiencing lightning surges. Please continue use of the unit as this is standard operation.

COMPONENT IDENTIFICATION

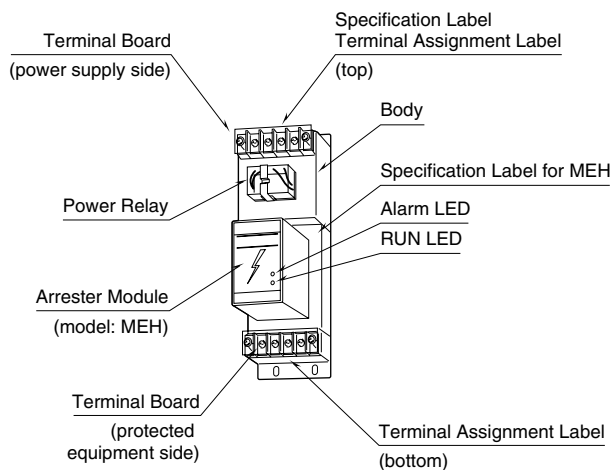

FRONT PANEL CONFIGURATION ARRESTER MODULE (model: MEH)

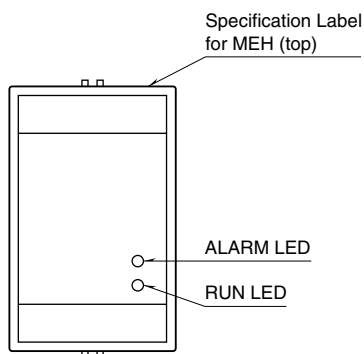

The MEH's model suffix codes change according to the power input voltage. Check the specification on the label.

INSTALLATION

Refer to the drawings below.

EXTERNAL DIMENSIONS unit: mm (inch)

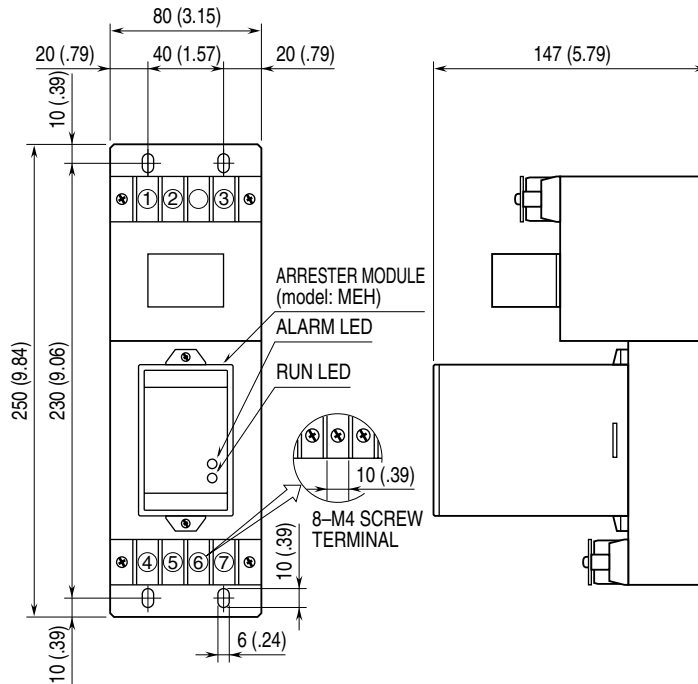

MOUNTING REQUIREMENTS mm (inch)

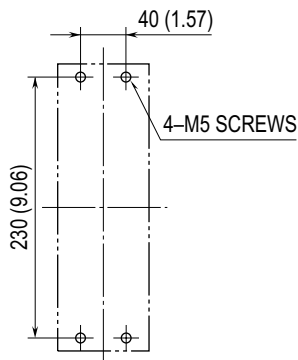

TERMINAL CONNECTIONS

Connect the unit as in the diagram below.

Be sure to cross-wire between the terminal 3 and the ground terminal of the protected equipment. (100Ω max.)

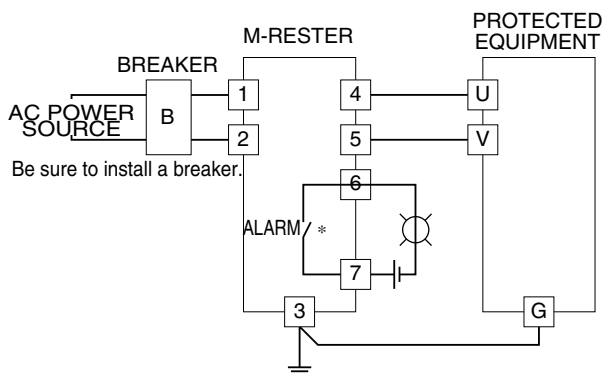

*Turns on at the alarm condition.

GROUNDING

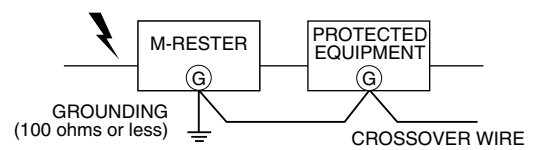

A crossover wire between M-RESTER ground and ground or metallic housing of equipment is required for protection. If the protected equipment has no ground terminal, ground the M-RESTER only.

ARRESTER MODULE ELEMENT

The MEH indicates its failure with contact output (ON) and front indicator LED (red). In such condition, replace the MEH as soon as possible.

REPLACING THE MEH

Remove the screws attaching the clamps to the MMH body, and pull the MEH off. Plug a new MEH into the socket and secure the clamps with the screws. (See the figure below.)

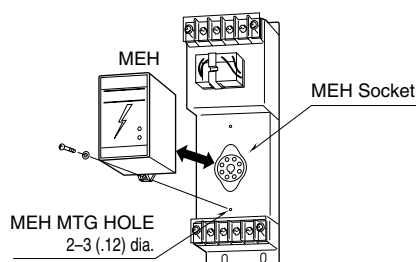

Clamps

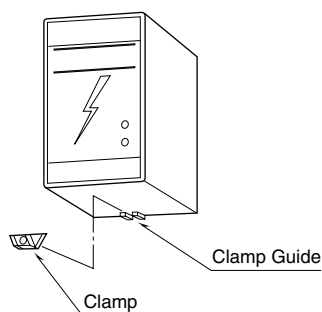

The replacement MEH is available with following model No.

MEH-1: for 100V/110V AC power

MEH-2: for 200V/220V AC power

We recommend that you keep spare MEHs so that you can replace them when necessary.

MAINTENANCE

Check M-RESTER periodically. Many cases of lightning are ignored, and even lightning at a far distance often causes inductive surges.

We recommend that you check your M-RESTER about twice a year, before and after the rainy season. Check whenever you experience a strong lightning occurrence.

Checking procedure is explained in the following:

CHECKING

A) ALARM Contact and LED:

Check the ALARM contact relay status and its LED on the front of the MEH. When the red light is turned ON, unplug the MEH and return it again, and check that the light is still ON. Then replace the MEH according to the procedure described in the left. If the light turns OFF when you return it, continue use of the unit as this is standard operation.

B) RUN LED:

If the RUN LED (green) remains OFF when you turned the power supply ON, replace the MEH.

C) Wiring:

Make sure that the terminal (3) is connected to the metallic

housing of the unit and that of protected equipment.

D) Discharge Function of the MEH:

Remove the MEH and test its discharge capability as follows:

- Check resistance across the following terminals: (3) – (4), (3) – (6), (4) – (6) (infinite standard).
- Check that discharging occurs across the same terminals with a 1000V DC megger. (Indicator of the megger reaches overscale.)

E) Leakage Current (between lines)

Return the MEH and apply supply voltage across the terminals (1) – (2) with no load, and measure current at the terminal (1). ($\leq 50\text{mA}$ standard for MEH-1; $\leq 30\text{mA}$ for MEH-2)

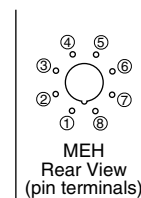

F) If any of the above tests shows negative, replace the MEH after that you confirm that the main body unit functions properly with the following tests. If the following tests show negative, replace the whole M-RESTER unit.

G) Main Body Unit Test

- Remove the MEH and all wiring and check resistance across the following terminals. ($\leq 0.5\Omega$ standard)
Terminals (1) – (4), (2) – (5)
- With the MEH and all wiring detached, check resistance across the following terminals. (infinite standard)
Terminals (1) – (2), (1) – (3), (2) – (3)
- Check that discharging occurs across the same terminals with a 1000V DC megger. (Indicator of the megger reaches overscale.)