

BEFORE USE

Thank you for choosing us. Before use, please check contents of the package you received as outlined below.

If you have any problems or questions with the product, please contact our sales office or representatives.

■ PACKAGE INCLUDES:

HLS Master Module.....	(1)
Front Panel.....	(1)

■ MODEL NO.

Confirm that the model number described on the product is exactly what you ordered.

■ INSTRUCTION MANUAL

This manual describes necessary points of caution when you use this product, including installation, connection and basic maintenance procedures.

POINTS OF CAUTION**■ CONFORMITY WITH EC DIRECTIVES**

- Use dual-shield cables (Shinko Seisen Industry Model ZHY262 PBA) for the network. If it is not sufficient, use a ferrite core (Kitagawa Industries Model RFC-20) for the network cable.
- The actual installation environments such as panel configurations, connected devices and connected wires may affect the protection level of this unit when it is integrated in a panel system. The user may have to review the CE requirements in regard to the whole system and employ additional protective measures to ensure CE conformity.

■ UNPLUGGING THE MODULE

- Before you remove the module from its base or mount it, turn off the power supply for safety.

■ ENVIRONMENT

- Indoor use
- When heavy dust or metal particles are present in the air, install the unit inside proper housing with sufficient ventilation.
- Do not install the unit where it is subjected to continuous vibration. Do not subject the unit to physical impact.
- Environmental temperature must be within 0 to +55°C (32 to 131°F) with relative humidity within 30 to 90% RH in order to ensure adequate life span and operation.

■ WIRING

- Do not install cables (power supply, input and output) close to noise sources (relay drive cable, high frequency line, etc.).
- Do not bind these cables together with those in which noises are present. Do not install them in the same duct.

COMPONENT IDENTIFICATION

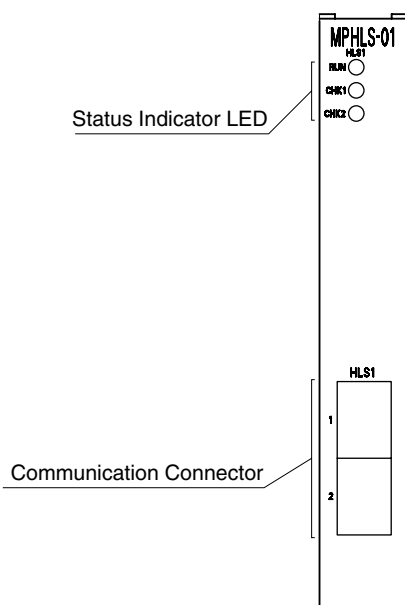

■ STATUS INDICATOR LED

ID	COLOR	FUNCTION
RUN	Green	ON when normal communication.
CHK1	Amber	ON when communication error occurs once.*1
CHK2	Red	ON when communication error consecutively occurs 3 times.*2

*1. When CHK1 is ON:

- LED turns OFF after LED ON for several msec.
- There may be some problem in packet transmitting/receiving affected by invasion of noise or environmental deterioration. Install the communication cable away from a noise source. Review the ground point and method of communication cable.
- The network performance may be close to the limit. Confirm that the configuration of communication mode, baud rate, address and termination resistor is appropriate. Transmission distance must be less than specification. Confirm that the number of connected slave station is less than 32 per connector.

*2. When CHK2 is ON:

- LED turns OFF after LED ON for several msec.
- A slave station may be disconnected. Confirm that there is no communication cable broken or disconnected.
- The system may be operating in extremely poor environment. Install the communication cable away from a noise source. Review the ground point and method of communication cable.
- The network performance may be close to the limit. Confirm that the configuration of communication mode, baud rate, address and termination resistor is appropriate. Transmission distance must be less than specification. Confirm that the number of connected slave station is less than 32 per connector.

■ Recommended cable connector: TM21P-88P (Hirose Electric)
(Not included in the package)

Full-duplex communication

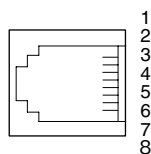

1. NC	No connection
2. NC	No connection
3. TXD+	Network (Slave, transmission +)
4. TXD-	Network (Slave, transmission -)
5. RXD+	Network (Master, transmission+)
6. RXD-	Network (Master, transmission-)
7. NC	No connection
8. SLD1	Shield

Half-duplex communication

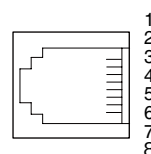

1. NC	No connection
2. NC	No connection
3. TR+	Network (+)
4. TR-	Network (-)
5. NC	No connection
6. NC	No connection
7. NC	No connection
8. SLD1	Shield

Max. number of slave station

HLS1-1 port: 32, HLS1-2 port: 31

INSTALLATION

Refer to the users manual for the MP2200/MP2300/MP3300 series basic module when installing and exchanging the unit.

TERMINAL CONNECTIONS

Connect the unit as in the diagram below.

■ DIMENSIONS mm (inch)

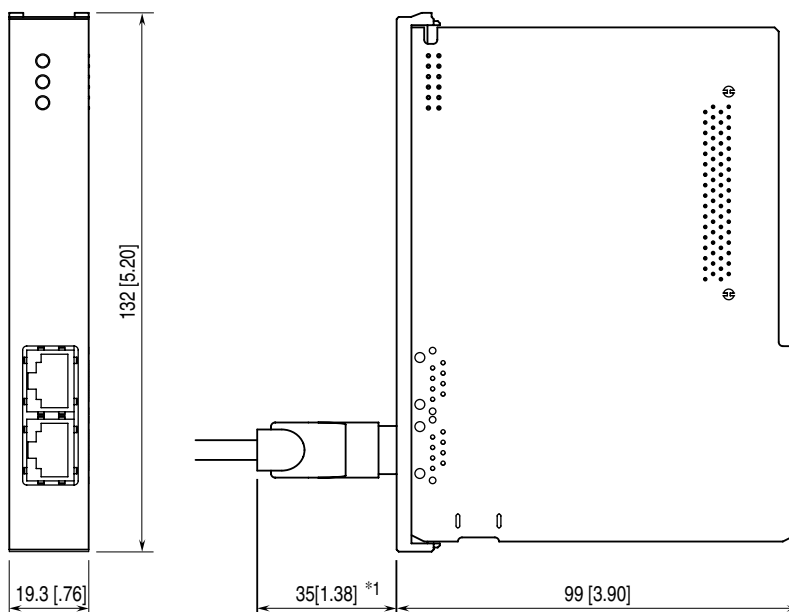

*Recommended cable connector: TM21P-88P (Hirose Electric)

■ CONNECTION DIAGRAM

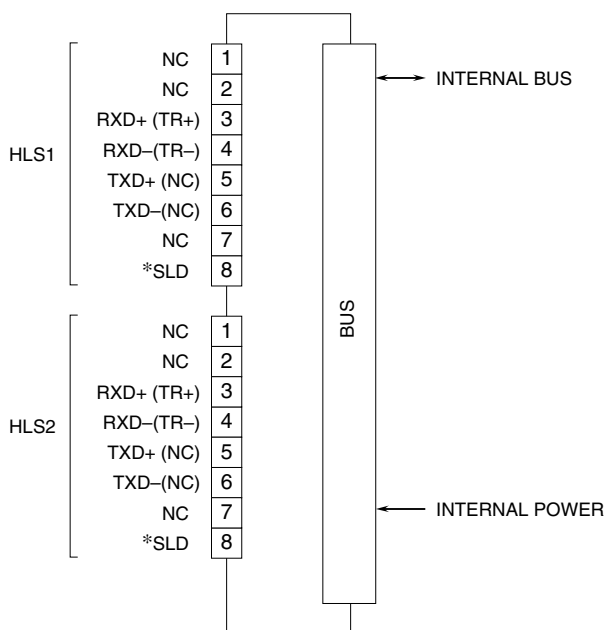

*SLD is connected to FG terminal of the MP2200 / MP2300 series machine controllers.

CONFIGURATION WITH PROGRAMMING TOOL

How to define the MPHLS-01 module with the Engineering View of the software for programming device, MPE720 (YASKAWA Electric Corp.)

■ AVAILABLE VERSIONS

- MP2200/MP2300 series machine controller (YASKAWA Electric Corp.)
Ver.2.84 or later
Software for programming device: MPE720
Ver.6.36 or later OR Ver.7.22 or later
- MP3300 series machine controller (YASKAWA Electric Corp.)
Ver.1.12 or later
Software for programming device: MPE720
Ver.7.28 or later

1. MODULE CONFIGURATION

The module configuration view is shown below.

The slot No. and register No. for the module are configured with this view. MPHLS-01 module has HLS-M function (1:N). The registers used by HLS-M are 40H (64) words fixed for each IN and OUT.

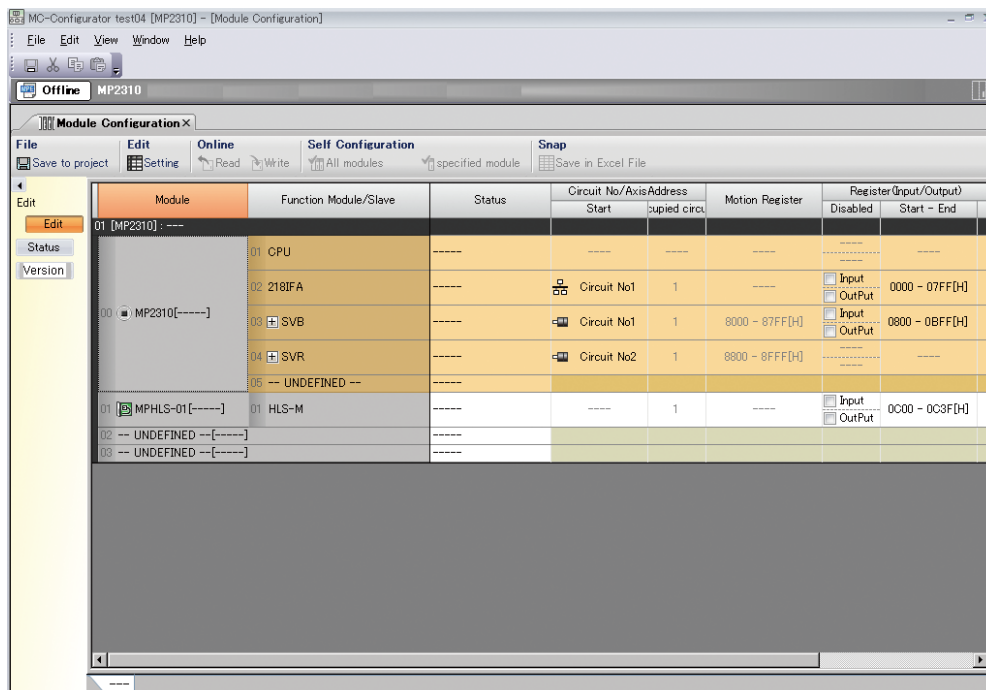

2. HLS-M DETAIL

The HLS-M detail view is shown below.

The transmission parameters and I/O register are configured with this view.

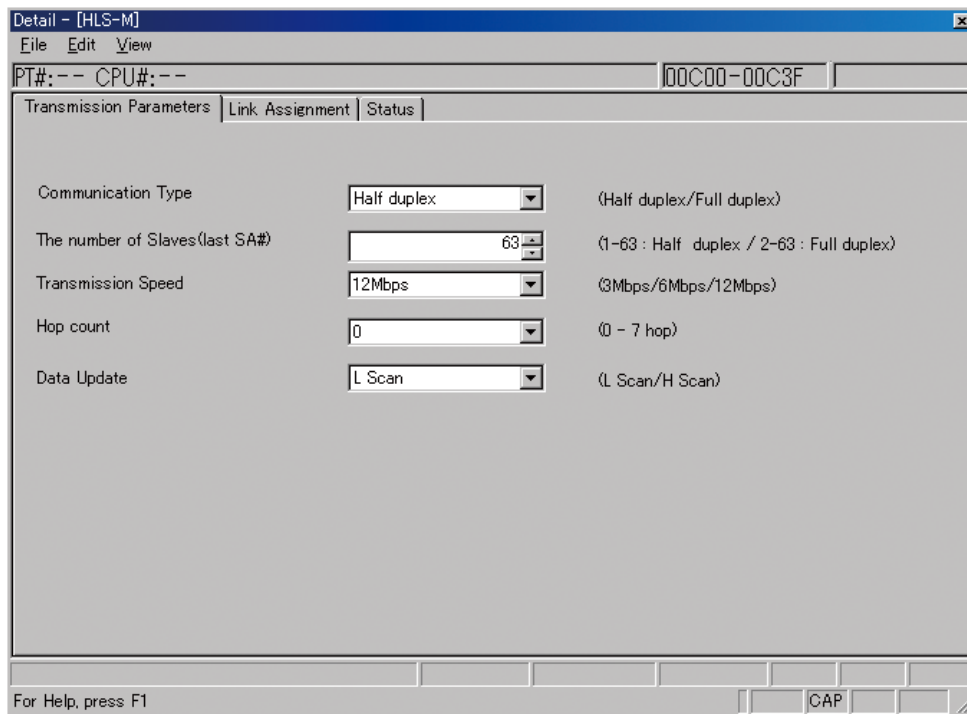

2.1 TRANSMISSION PARAMETERS

1. Communication Type
Half duplex / Full duplex

2. The number of Slaves (last SA#)
Half duplex: 1 to 63
Full duplex: 2 to 63
(Factory setting: 63)

3. Transmission Speed
3 Mbps / 6 Mbps / 12 Mbps (*)

4. Hop Count
0 (*) to 7 hop

5. Data Update
L Scan (*) / H Scan

(*): Factory setting

2.2 LINK ASSIGNMENT

Slave station has address, which is set with rotary switch, to identify each station. This physical address is called as "SA". SA starts with 01.

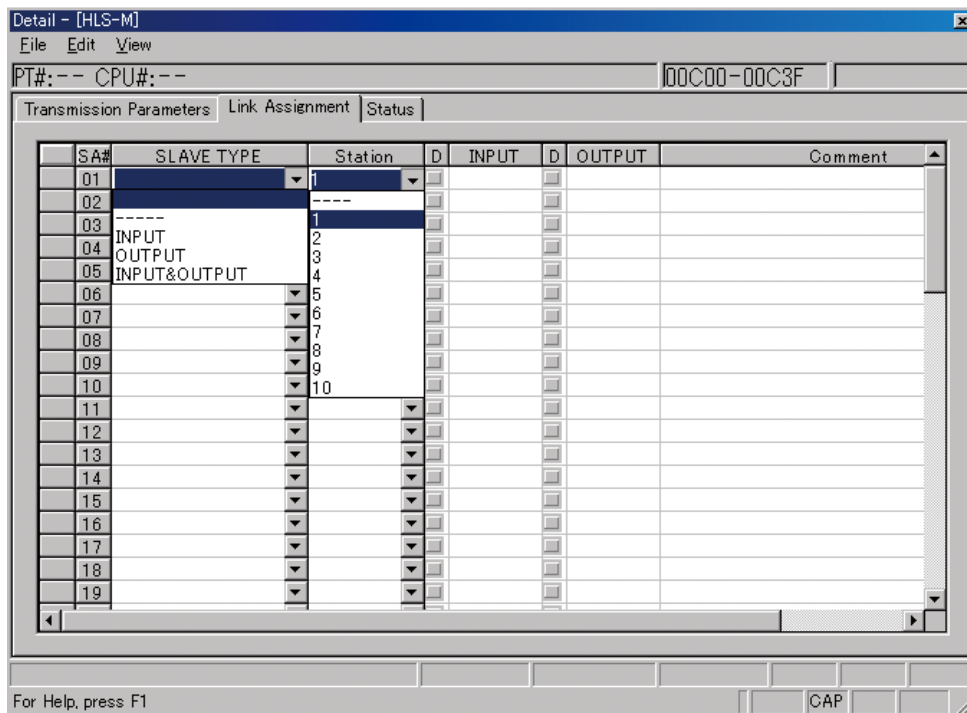

1. SA#

Slave station address is shown. The number of slave station address displayed is set in Transmission Parameters Tab as last SA#.

2. SLAVE TYPE

Slave type is assigned.

INPUT: Slave only for input

OUTPUT: Slave only for output

INPUT & OUTPUT: Slave for both input and output

----: Slave cannot be assigned because other slave, which has two or more allocate number, is allocated.

3. STATION

The number of stations (1 to 10) allocated by slave is configured.

When Communication Type is half duplex, slave allocates in series. When Communication Type is full duplex, slave allocates alternately. The way the number of stations allocated changes HLS scan mode. For detailed information refer to "HLS SCAN MODE".

4. D

Input or output is disabled. SA, which is not allocated to slave, cannot be configured.

5. INPUT/OUTPUT

Beginning register, at which the unit inputs or outputs data with slave, is displayed.

The register number is assigned automatically by choosing slave type, it cannot be changed.

6. COMMENT

Comment, max. 32 characters, for each slave can be entered.

2.3 MAINTENANCE

Status for each SA is displayed.

The status is saved also in error status of system register.

OK: Normal communication

NG: Abnormal communication

Detail - [HLS-M]
 File Edit View
 PT#: 1 CPU#: 1 00C00-00C3F

Transmission Parameters Link Assignment Status

ST#	STS	ST#	STS	ST#	STS	ST#	STS
01	OK	17	----	33	----	49	----
02	NG	18	----	34	----	50	----
03	OK	19	----	35	----	51	----
04	----	20	----	36	----	52	----
05	NG	21	----	37	----	53	----
06	----	22	----	38	----	54	----
07	----	23	----	39	----	55	----
08	----	24	----	40	----	56	----
09	----	25	----	41	----	57	----
10	----	26	----	42	----	58	----
11	----	27	----	43	----	59	----
12	----	28	----	44	----	60	----
13	----	29	----	45	----	61	----
14	----	30	----	46	----	62	----
15	----	31	----	47	----	63	----
16	----	32	----	48	----		

For Help, press F1 CAP

DATA ALLOCATION

■ INPUT DATA

Description for input data.

Name	Register Number	Description
SA01 Input	IWxxxx + 00	Input data for each SA (1W per 1SA)
SA02 Input	IWxxxx + 01	
:	:	
SA62 Input	IWxxxx + 3D	
SA63 Input	IWxxxx + 3E	
System reserved	IWxxxx + 3F	

* "xxxx" refers to beginning register number.

■ OUTPUT DATA

Description for output data.

Name	Register Number	Description
SA01 Output	OWxxxx + 00	Output data for each SA (1W per 1SA)
SA02 Output	OWxxxx + 01	
:	:	
SA62 Output	OWxxxx + 3D	
SA63 Output	OWxxxx + 3E	
System reserved	OWxxxx + 3F	

* "xxxx" refers to beginning register number.

■ SYSTEM REGISTER

Communication status for each slave of MPHLS-01 module is reported to the system register shown below.

System I/O Error Status (MP2200/MP23xx/MP3300)

Name	Register Number	Description
Rack 1 Slot 0 Error status	SW00208 – SW00223	MP2200/MP3300: CPU-0x module error status MP23xx: MP23xx error status
Rack 1 Slot 1 Error status	SW00224 – SW00231	Contents differ depends on attached module
Rack 1 Slot 2 Error status	SW00232 – SW00239	
Rack 1 Slot 3 Error status	SW00240 – SW00247	
:	:	
Rack 1 Slot 8 Error status	SW00280 – SW00287	Ditto
Rack 2 Slot 1 Error status	SW00288 – SW00295	Ditto
:	:	
Rack 2 Slot 9 Error status	SW00352 – SW00359	Ditto
Rack 3 Slot 1 Error status	SW00360 – SW00367	Ditto
:	:	
Rack 3 Slot 9 Error status	SW00424 – SW00431	Ditto
Rack 4 Slot 1 Error status	SW00432 – SW00439	Ditto
:	:	
Rack 4 Slot 9 Error status	SW00496 – SW00503	Ditto

System I/O Error Status (MP2100M)

Name	Register Number	Description
Rack 1 Slot 0 Error status	SW00208 – SW00223	MP2100M error status
Rack 1 Slot 1 Error status	SW00224 – SW00231	Contents differ depends on attached module
Rack 1 Slot 2 Error status	SW00232 – SW00239	
Rack 2 Slot 1 Error status	SW00240 – SW00247	
:	:	
Rack 2 Slot 9 Error status	SW00304 – SW00311	Ditto
Rack 3 Slot 1 Error status	SW00312 – SW00319	Ditto
:	:	
Rack 3 Slot 9 Error status	SW00376 – SW00383	Ditto
Rack 4 Slot 1 Error status	SW00384 – SW00391	Ditto
:	:	
Rack 4 Slot 9 Error status	SW00448 – SW00455	Ditto

· Error status for HLS-M module (e.g. For Rack 1 / Slot 1)

	F	1	0	(Bit number)
SW00224	SA15	SA01	0 fixed
SW00225	SA31	SA17	SA16
SW00226	SA47	SA33	SA32
SW00227	SA63	SA49	SA48
SW00228	Not used			
SW00229	Not used			
SW00230	Not used			
SW00231	Not used			

Error Status Detail

ITEM	CODE	DESCRIPTION
SAn	0	Normal communication
	1	Abnormal communication

HLS SCAN MODE

The unit has two scan modes for HLS communication; they are continuous scan and single scan.

■ CONTINUOUS SCAN

The scan for HLS communication is performed continuously. For transmitting or receiving discrete data and 1 word (16 bits) data, continuous scan is performed. Punctuality of HLS communication is kept. When link assignment is configured by slave with only one station, continuous scan is performed.

■ SINGLE SCAN

The scan for HLS communication is performed for one time. When two or more words are handled in HLS communication, performing continuous scan may results disruption of data in between words. Therefore reading or writing all data with stopping the scan at every one scan enables to avoid disruption of data. Punctuality of HLS communication is NOT kept. When link assignment is configured by one or more slave with two or more stations, single scan is performed.

Example 1. Assigning R7HL-SV4

R7HL-SV4 is 4 points DC voltage/current input module with Station: 4. Because its analog data consist of "1 word x 4ch", data is independent with respect to each one word. Therefore assign four slaves with station: 1, perform continuous scan, for there is no need to consider disruption of data in between words. Be aware that address allocation is in series for half-duplex communication, alternately for full-duplex communication. It is possible to assign one slave with station: 4, and to perform single scan.

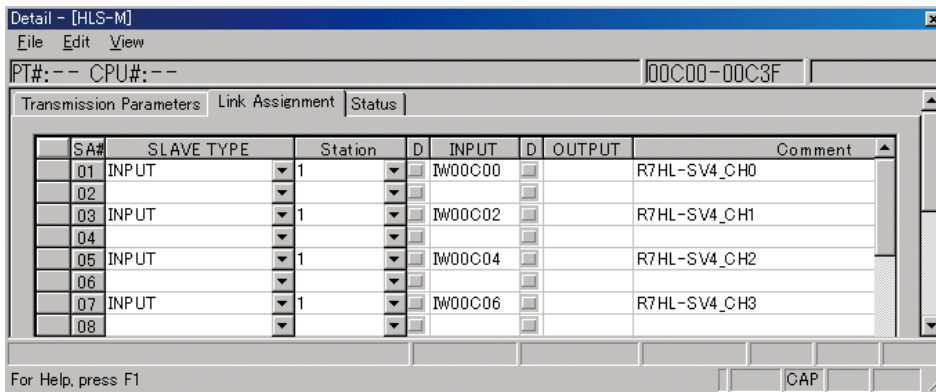

Example 2. Assigning R7HL-PA2S

R7HL-PA2S is 2 channels encoder input module with Station: 4. Because its analog data consist of "2 word x 2ch", considering disruption of data in between words is required. Assign one slave with station: 4, and to perform single scan. Allocated address is assigned automatically.

