

STEP-TOP ELECTRONIC ACTUATOR
(Rotary type; Modbus communication)

MODEL **MRP11**

BEFORE USE

Thank you for choosing us. Before use, please check contents of the package you received as outlined below.

If you have any problems or questions with the product, please contact our sales office or representatives.

■ PACKAGE INCLUDES:

Step-Top Electronic Actuator unit.....(1)

The Step-Top Electronic Actuator is not provided with a yoke or other components required for mounting the unit to a valve. They are to be provided by the user.

■ MODEL NO.

Confirm Model No. marking on the product to be exactly what you ordered.

■ SAFETY PRECAUTIONS

Before use, please read all the following precautions carefully to ensure the safety. These safety precautions, classified into “WARNING” and “CAUTION” according to the degree of damage that may be caused by improper use of the product, are imperative to prevent an accident. After reading, be sure to keep this manual always in a visible and accessible place for the user.

△ **WARNING** Suggesting that failure to observe the precautions could result in death or serious personal injury.

△ **CAUTION** Suggesting that failure to observe the precautions could result in personal injury or damage to the property.

△ WARNING
Remove power supply to the actuator before wiring to the unit. It could cause electric shock.
Do not disassemble or modify the unit in any way. It could cause electric shock, burn, or injury.
DO NOT step onto the actuator unit. DO NOT rest a heavy object on or against the unit. It could cause personal injury.
When installing the actuator unit outdoor or where it is exposed to rain or water drops, adequate precautions must be taken for preventing water from entering inside through wiring conduits. It could cause electric shock.

△ CAUTION
DO NOT remove the cover of the actuator. It may cause electric shock or injury.
The adjusters which are paint-sealed are for factory use only and should be changed only by qualified our personnel. Otherwise it could cause breakdown. We are not liable for any malfunction or inconvenience caused by unauthorized changes made by the user.

■ INSTRUCTION MANUAL

This manual describes necessary points of caution for handling this product and specifically for installation, wiring, hardware setting, and basic maintenance of the product.

This unit is factory-adjusted and calibrated according to the Ordering Information Sheet.

When the user needs to change settings, please also refer to the Section B of Operation Manual (EM-9255) for the Programming Unit (Model: PU-2x).

POINTS OF CAUTION

■ CONFORMITY WITH EU DIRECTIVES AND UK LEGISLATION

- This equipment is suitable for Pollution Degree 2 and Installation Category II (Transient voltage 2500V). Basic insulation (I/O signal or full-open/-closed signal or alarm signal or communication or metallic housing to power voltage: 300 V) is maintained. Prior to installation, check that the insulation class of this unit satisfies the system requirements.
- Refer to our website for more information about the legislations and designated standards of UKCA.
- Altitude up to 2000 meters.
- The equipment must be installed such that appropriate clearance and creepage distances are maintained to conform to CE and UKCA requirements. Failure to observe these requirements may invalidate the CE and UKCA conformance.

■ POWER INPUT RATING & OPERATIONAL RANGE

- Locate the power input rating marked on the product and confirm its operational range as indicated below:
100 – 120V AC rating: 90 – 132V, 47 – 66 Hz, approx. 180VA
200 – 240V AC rating: 180 – 264V, 47 – 66 Hz, approx. 180VA

■ HUNTING

- Hunting is a condition in which the output stem is oscillated repeatedly and persistently without settling at a single position.
- The actuator unit must operate at an average duty cycle of 50% (approx. 13 strokes per minute) or less.

■ GENERAL PRECAUTIONS

- Remove the power supply to the actuator before wiring the unit.
- DO NOT install signal wires and power supply wires together in one duct because it may cause a malfunction due to induction noises. Alternatively, use shielded cables for the input signal wires to prevent interference from such noises.
- If input signals are to be turned on/off with power supplied to the actuator, be sure to specify the output stem operation when abnormally low input is detected.
- DO NOT loosen the screws fixing the potentiometer inside the unit.

■ INSTALLATION

- Indoor, or outdoor where the unit is NOT exposed to direct sunlight.
- Operating temperature -40 to +75°C (-40 to +167°F)
- Operating humidity 30 to 90% RH (non-condensing)
- The unit is not designed to withstand all vibrations. We do not guarantee long-term use of the unit even with small vibrations. Please use the unit only after evaluating in an actual installation environment. Particularly, avoid using under the condition where valve cavitation or water hammer is likely to occur.
- Install the unit where it can be reached for maintenance and inspection. Be sure to allow at least 20 cm (7.9 inches) clearance above the unit and around the terminal box.
- Keep away from hazardous atmosphere such as explosive or corrosive gases.

■ PID CONTROL SIGNAL

- Choose PID parameters carefully so that the MV remains as stable as possible to prevent hunting. Unstable control shortens the life of actuator and valve.

■ TRANSPARENT COVER FOR TERMINAL BOX

- When reattaching the transparent cover after wiring, make sure that the packing and O ring are securely in place.

■ SCREW TORQUE

- The torque for tightening screws for the transparent cover is between 1.2 – 2 N·m (0.89 – 1.5 ft·lbf). The screws must be tightened evenly and crosswise in several steps to prevent uneven clamping.

■ YOKE DESIGN

- When a foreign object is caught in the valve, an excessive torque may be applied to the yoke. Taking it into account, design the yoke and joint so as to have sufficient margin in strength.
- When this unit is used in an application such as temperature control of a steam line, the temperature can rise higher than the ambient temperature due to heat conducted through or radiated from the piping. Use a longer yoke for effective heat dissipation and apply insulation material.

■ HEATER FUNCTION AT LOW TEMPERATURE

- Apply power voltage when the temperature is 0°C or under. Sensor inside the unit is activated at 0°C or under, and stepping motor starts heater function.
- A heater is incorporated to use under cold areas. Automatically starts heating when surface temperature of the stepping motor is under 0°C (32°F) and automatically stops heating over 2°C (35.6°F).
- Be sure to apply power voltage even when the MRP is unused.

Note. Storage temperature (-29 to 70°C (-20.2 to +158°F)) is for before piping. Once the MRP is piped, the temperature must be in the range of operation temperature. When using the MRP at the first time in -25°C (-13°F), apply the power voltage and take 30 minutes of hold time before using the MRP.

■ COVER

- No need to remove the cover. All wiring, adjustments, indicator LEDs are in the terminal BOX. Remove the transparent cover to work.
- The quality inside the mechanism is stabilized by not removing the cover.

COMPONENT IDENTIFICATION

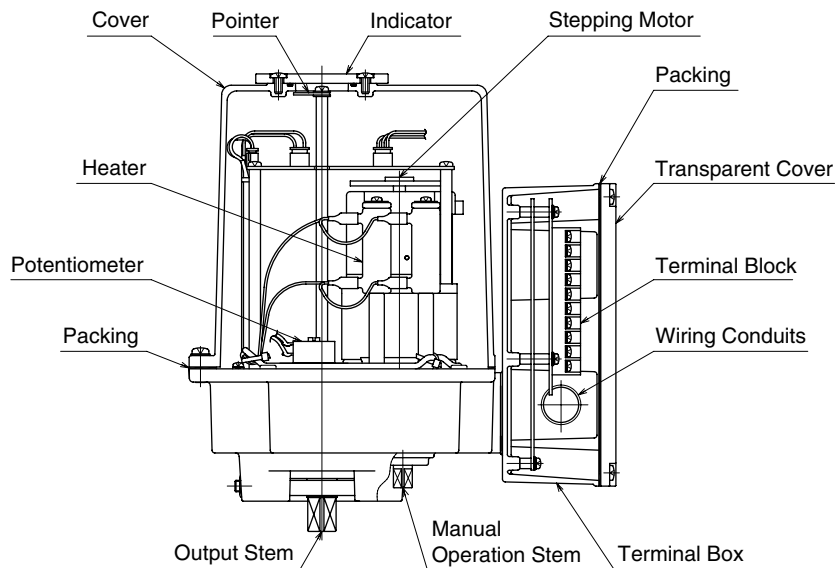

Figure 1. Component identification: MRP11

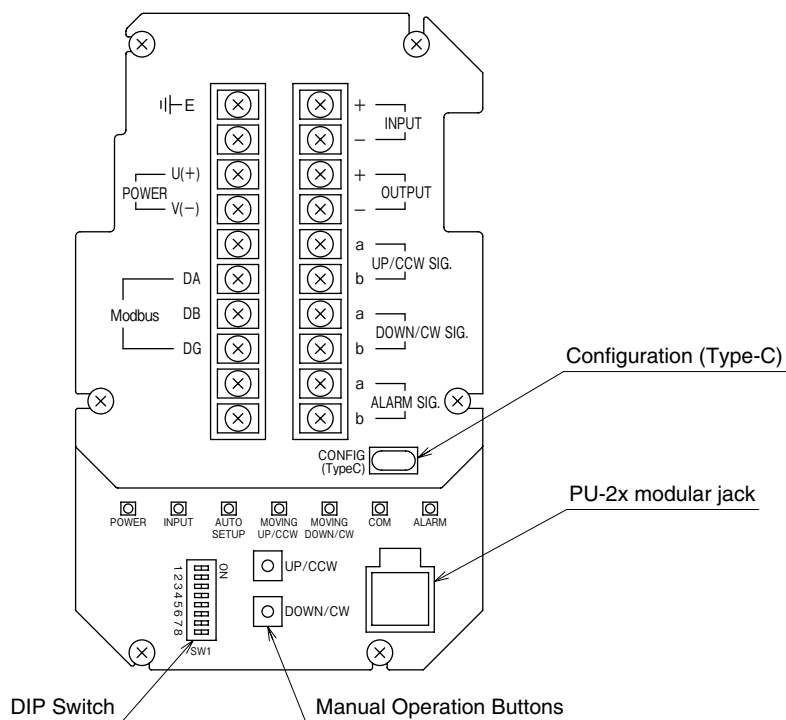

Figure 2. Component identification: Terminal Box

STATUS INDICATOR LED AND SIDE DIP SWITCH

■ STATUS INDICATOR LED

ID	COLOR	STATUS	FUNCTION
POWER	Green	ON	Power is ON.
INPUT	Green	ON	Position setpoint input (analog) of 0.37 V or greater is applied. (With 250 Ω receiving resistor for current input)
AUTO-SETUP	–	–	–
MOVING UP/CCW	Green	ON	The output stem is turning left viewing from the top of the cover.
MOVING DOWN/CW	Green	ON	The output stem is turning right viewing from the top of the cover.
COM	Green	ON for 1 sec.	Responding to Modbus.
ALARM	Red	Blinks at 0.5 Hz	System error (memory)
		ON	Motor deadlock alarm is output.
		Blink at 2 Hz	Motor is overheat.

■ SIDE DIP SWITCH SETTING

SW1	FUNCTION		
SW1-1 SW1-2	Specify the operation of the output stem when abnormally low input is detected. (INPUT LED is OFF).		
	SW1-1	SW1-2	Operation of the Output Stem
	–	ON	Stop
	OFF	OFF	Output stem stops at full-close position.
	ON	OFF	Output stem stops at full-open position.
SW1-3	OFF	Reverse (Output stem moves to full-open side with 20 mA DC input)	
	ON	Direct (Output stem moves to full-close side with 20 mA DC input)	
SW1-4	OFF	Output signal is same as input signal.	
	ON	Output signal is reversed input signal.	
SW1-5	The output stem position when the switch is turned OFF is recorded as the full-open position.		
SW1-6	The output stem position when the switch is turned OFF is recorded as the full-close position.		
SW1-7	–		
SW1-8	OFF	Automatic operation	
	ON	Manual operation (Manual operation buttons are enabled.)	

■ MANUAL OPERATION BUTTON

ID	FUNCTION
UP/CCW	The output stem turns left to full-open side in Manual Operation mode as the button is pressed. (Viewing from the top of the cover.)
DOWN/CW	The output stem turns right to full-close side in Manual Operation mode as the button is pressed. (Viewing from the top of the cover.)

■ USB Type-C

Connecting the MRP and the PC via USB Type-C cable and using the PC configurator software, various settings and monitoring operation status can be performed.

■ PU-2X MODULAR JACK

Parameter settings for Auto-setup and communication settings for Modbus can be configured on PU-2x. In addition, operation status of the unit can be monitored on PU-2x.

WIRING CONNECTION

Remove the transparent cover for terminal box and wire to the terminal block according to the below figure.

The unit can be operated once the power voltage and input signal are connected.

Also wire full-open, full-close, alarm, and/or output signals, as necessary.

Modbus communication allows operation without analog input and monitoring of the operation status of the unit.

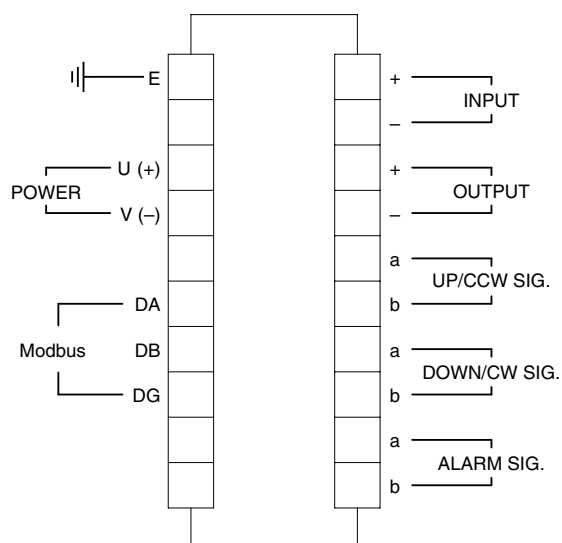

COMMUNICATION CABLE CONNECTIONS

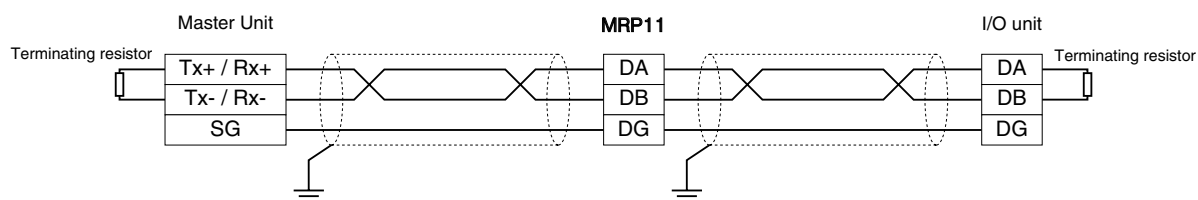

Terminating resistors can be turned ON/OFF on the PC configurator software (model: STCFG) or programming unit (model: PU-2x).

OPERATION

■ CCW. and CW.

Operation	Input Signal	Output Signal	Output Stem Position	Output Stem Angle	Indicator Symbol	Output Stem Rotation (View from the top of the cover)
CCW.	4 mA DC	4 mA DC	Full-shut	0°	S	CW.
	20 mA DC	20 mA DC	Full-open	90°	O	CCW.
CW.	4 mA DC	4 mA DC	Full-open	90°	O	CCW.
	20 mA DC	20 mA DC	Full-shut	0°	S	CW.

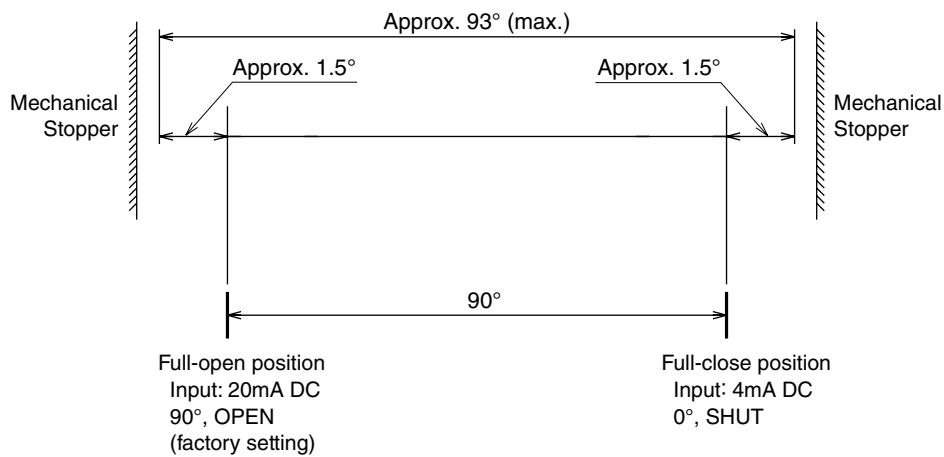

HOW TO USE MANUAL OPERATION BUTTON

- Operation angle can be adjusted by the UP/CCW / DOWN/CW button.

Turn SW-8 from OFF to ON to enable manual operation (If SW-8 is kept OFF, control by input signal takes priority over Manual operation).

Adjust the position of the output stem by UP/CCW / DOWN/CW button.

Perform the following procedure after position adjustment.

<After completion of full-close position adjustment>

Turn SW1-5 OFF -> ON -> OFF to set full-open position newly.

<After completion of full-open position adjustment>

Turn SW1-6 OFF -> ON -> OFF to set full-close position newly.

PC CONFIGURATOR SOFTWARE (MODEL: STCFG)

The PC configurator software helps the user to configure various parameters and to monitor operation status of the actuator.

Download the STCFG from "Download" on the our web site.

Prepare the PC and the USB Type-C cable separately.

For details, refer to STCFG users manual.

PROGRAMMING UNIT (MODEL: PU-2x)

The Programming Unit (model: PU-2x) helps the user to configure various parameters and to monitor operation status of the actuator.

Turn SW1-8 ON to enable configuration on PU-2x.

Monitoring can be conducted regardless of whether SW1-8 is ON or OFF.

■ DISPLAY OF PU-2x

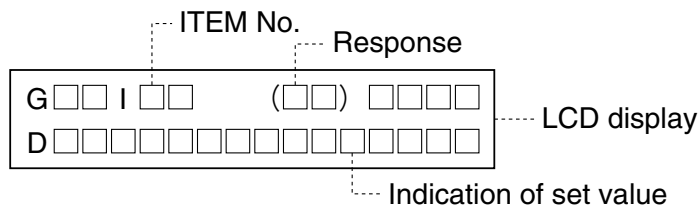

■ HOW TO USE PU-2x

- 1) Turn SW1-8 ON to enable configuration.
- 2) Connect the connection cable of PU-2x to the modular jack on the actuator unit.
The display of PU-2x comes on by power supplied to the actuator unit.
- 3) To display a target item, press [ITEM], then [N], [N] ([N] represents numerical number 0 to 9).
Alternatively, use [UP] or [DOWN] button to shift to the next item from the currently displayed item.
- 4) To change the setting value of the target item being displayed, press [DATA], enter a value, and press [ENTER].
Enter an integer or a value with two decimal place depending on the item.
When setting a tag, alphabetic characters can be used.
- 5) Confirm that 'OK' is displayed.
If the entered value is invalid or SW1-8 is OFF, 'DATA-ERR' will be displayed.
- 6) When configuration or Auto-setup is completed, remove the connect cable of PU-2x from the actuator unit, and turn SW1-8 OFF.

■ RESPONSE MESSAGES

OK : OK
 NON-ITEM : Item is not applicable
 DATA-ERR : Value is invalid or out of range

■ PARAMETER ITEM LIST

Refer to "PARAMETER ITEMS COMMON TO MODBUS, CONFIGURATOR SOFTWARE AND PU-2x" for the parameter item list.

MODBUS COMMUNICATION

Modbus communication allows monitoring of the operation status of the actuator in the same manner as the programming unit (model: PU-2x) and the PC configurator software.

Position set point can be input via Modbus instead of analog signal.

MODBUS COMMUNICATION SPECIFICATION

This unit supports Modbus-RTU protocol.

ITEM	SETTING RANGE	EX-FACTORY SETTING
Node address	1 to 247	1
Baud rate	38400, 19200, 9600, 4800 bps	38400 bps
Parity	None, Odd, Even	None
Stop bit	1, 2	1

MODBUS COMMANDS

FUNCTION	COMMAND	DESCRIPTION
03	Read Holding Registers	Reads the value(s) of a single or multiple holding registers.
04	Read Input Registers	Reads the value(s) of a single or multiple input registers.
06	Preset Single Register	Presets a value in a single holding register.
16	Preset Multiple Registers	Presets values in respective multiple holding registers.

It is recommended to set timeout for response to 0.5 sec. or longer.

'0' is returned when an address to which no register is assigned is read.

An exception response is returned when attempting to write to an address which is not writable.

Even if the address is writable, make sure to set [Modbus Operation mode (address 111)] in advance to enable writing.

ADDRESS MAP

Refer to "PARAMETER ITEMS COMMON TO MODBUS, CONFIGURATOR SOFTWARE AND PU-2x" for Modbus address map.

DATA VALUE

When [Value Range] of the data is specified as numbers with one digit after the decimal point, the data is multiplied by 10 and handled as an integer. That is, '25.8' is handled as '258', for example.

When the Data type is 'I16', data is an integer between -32768 to 32767, and when the Data type is 'I32', data is a long 32-bit integer between -2147483648 to 214783647.

Long data is in little endian format.

POSITION SETPOINT INPUT VIA MODBUS

The position setpoint can be input via Modbus communication by the following procedure.

- 1) Set [Input mode (Modbus=address 121, PU-2x= ITEM 30)] as 'Modbus input'.
- 2) Write a position setpoint value (e.g. '700' for 70.0 %) to Address 101.
- 3) Write '1' to Address 111 to enable Modbus input, thereby moving the output stem toward the setpoint.

Note)

- When a motor deadlock error occurs, '1' or '2' is set in Address 46.
Write '1' to Address 51 to clear the error.
- When [Modbus disconnection detection time (Modbus=address 127, PU-2x= ITEM 36)] is set, a Modbus disconnection error is detected when a Modbus command is not issued for the set time period, thereby causing the output stem to stop, to move to full-close side, or full-open side according to the settings of DIP switches 1-1 and 1-2 of the unit.
- Refer also to "COMBINATION OF OPERATION MODE AND SPECIFICATIONS".

PARAMETER ITEMS COMMON TO MODBUS, CONFIGURATOR SOFTWARE AND PU-2x

1.1. Note for parameter items

ITEM	DESCRIPTION
MODBUS TYPE	I16=Integer type data, I32=Long type data (little endian)
VALUE RANGE	Value with two decimal place is multiplied by 100 and handled as an integer. Value is used as is with one decimal place on PU-2x.
PU-2x DISPLAY	x represents a number.
R/W	R= Read only R/W=Read and Write
SAVE	Setting is saved for the item with '✓' in the [Save] column.
CFG	Configurable, monitorable items by the PC configurator software.

1.2. Device information

MODBUS		ITEM	VALUE RANGE	INITIAL VALUE	PU-2x		R/W	SAVE	CFG
ADDRESS	TYPE				ITEM	DISPLAY			
1	HEX	MRP11 unit ID	0x9141	–	01	Model:x	R	–	✓
2	I16	Firmware: Major version	0 to 9	–	02	Ver:x.y.z	R	–	✓
3	I16	Firmware: Minor version	0 to 99						
4	I16	Firmware: Revision	0 to 99						
5 to 16	I16 x 12	Tag setting · ASCII code (0x20 to 0x7E) · Stored in order from the head address · On PU-2x, enter characters as needed and the rest, if any, is entered as space.	ASCII code (0x20 to 0x7E) x 12 characters	blank (0x20)	03	Tg.xxxx...xx	R/W	✓	✓
17	I16	Analog input (%)	-25.0 to 125.0	–	04	Inp:x	R	–	✓
18	I16	Position setpoint (%)	-5.0 to 105.0	–	05	Tar:x	R	–	–
19	I16	Position (%)	-5.0 to 105.0	–	06	Pos:x	R	–	✓

Regarding the address 17 to 19, 0 is returned for approx. 1 sec. after startup.

1.3. Diagnostics

MODBUS		ITEM	VALUE RANGE	INITIAL VALUE	PU-2x		R/W	SAVE	CFG
ADDRESS	TYPE				ITEM	DISPLAY			
21	I32	Total power-on time (hour)	0 to 596523	0	07	PowTm:x	R	–	✓
23	I32	Total operation time (hour)	0 to 596523	0	08	MovTm:x	R	–	✓
25	I32	Total operation distance (1 count per operation distance)	0 to 99999999	0	09	Dist:x	R	–	✓
27	I32	No. of times of motor start actions	0 to 99999999	0	10	Strt:x	R	–	✓
29	I32	No. of times of motor reverse actions	0 to 99999999	0	11	Rvrs:x	R	–	✓
31	I32	No. of times of motor restart	0 to 99999999	0	12	Rtry:x	R	–	✓
33	I32	No. of times when the duty cycle per minute exceeded 50%	0 to 99999999	0	13	Over:x	R	–	✓
35	I16	Duty cycle (%) per minute	0.0 to 100.0	0.0	14	Duty:x	R	–	–
36	I16	Time ratio (%) of - 10% position	0.0 to 100.0	0.0	15	Pos0R:x	R	–	✓
37	I16	Time ratio (%) of 10 - 20% position	0.0 to 100.0	0.0	16	Pos10R:x	R	–	✓
38	I16	Time ratio (%) of 20 - 30% position	0.0 to 100.0	0.0	17	Pos20R:x	R	–	✓
39	I16	Time ratio (%) of 30 - 40% position	0.0 to 100.0	0.0	18	Pos30R:x	R	–	✓
40	I16	Time ratio (%) of 40 - 50% position	0.0 to 100.0	0.0	19	Pos40R:x	R	–	✓
41	I16	Time ratio (%) of 50 - 60% position	0.0 to 100.0	0.0	20	Pos50R:x	R	–	✓
42	I16	Time ratio (%) of 60 - 70% position	0.0 to 100.0	0.0	21	Pos60R:x	R	–	✓

MODBUS		ITEM	VALUE RANGE	INITIAL VALUE	PU-2x		R/W	SAVE	CFG
ADDRESS	TYPE				ITEM	DISPLAY			
43	I16	Time ratio (%) of 70 - 80% position	0.0 to 100.0	0.0	22	Pos70R:x	R	-	✓
44	I16	Time ratio (%) of 80 - 90% position	0.0 to 100.0	0.0	23	Pos80R:x	R	-	✓
45	I16	Time ratio (%) of 90% - position	0.0 to 100.0	0.0	24	Pos90R:x	R	-	✓
46	I16	Motor deadlock error 0: Normal 1: Locked when moving to full-open side 2: Locked when moving to full-close side	0 to 2	-	25	Lock:x	R	-	-

The diagnostic information of the device is saved to non-volatile memory at approx. 2 min. intervals.

Therefore, when the power voltage is turned off and then on, the data may return to a state from up to approx. 2 min. earlier depending on the timing of turning off the power voltage.

1.4. Clear diagnostics

MODBUS		ITEM	VALUE RANGE	INITIAL VALUE	PU-2x		R/W	SAVE	CFG
ADDRESS	TYPE				ITEM	DISPLAY			
51	I16	Clear motor dead lock error 1: Clear	0, 1	0	26	LockRelease:x	R/W	-	-
52	I16	Time ratio (%) of respective % positions 1: Clear	0, 1	0	27	PosRClr:x	R/W	-	✓

1.5. Modbus input

MODBUS		ITEM	VALUE RANGE	INITIAL VALUE	PU-2x		R/W	SAVE	CFG
ADDRESS	TYPE				ITEM	DISPLAY			
101	I16	Modbus position setpoint input (%)	-5.0 to 105.0	0	-	-	R/W	-	-

1.6. Modbus operation mode

MODBUS		ITEM	VALUE RANGE	INITIAL VALUE	PU-2x		R/W	SAVE	CFG
ADDRESS	TYPE				ITEM	DISPLAY			
111	I16	Modbus operation mode (Forcibly returned to '0' when SW1-8=ON) 0: Monitor mode 1: Modbus input mode 2: Configuration mode	0 to 2	0	-	-	R/W	-	-
<p>[0: Monitor mode]</p> <ul style="list-style-type: none"> · R/W registers of addresses up to 111 are readable and writable. · Registers other than the above are read only. 									
<p>[1: Modbus input mode]</p> <ul style="list-style-type: none"> · R/W registers of addresses up to 111 are readable and writable. · Registers other than the above are read only. · When [Input mode= Modbus input], the actuator operates according to [Modbus position setpoint input]. 									
<p>[2: Configuration mode]</p> <ul style="list-style-type: none"> · All R/W registers are readable and writable. · Registers other than the above are read only. · Operation stops. 									

1.7. Modbus setting

MODBUS		ITEM	VALUE RANGE	STANDARD EX-FACTORY	PU-2x		R/W	SAVE	CFG
ADDRESS	TYPE				ITEM	DISPLAY			
121	I16	Input Select 0: Analog input 1: Modbus input	0, 1	0	30	Inputsel:x	R/W	✓	✓
122	I16	Node address	1 to 247	1	31	Addr:x	R/W	✓	✓
123	I16	Baud rate 0: 38400 bps 1: 19200 bps 2: 9600 bps 3: 4800 bps	0 to 3	0	32	Baud:x	R/W	✓	✓
124	I16	Parity 0: None 1: Odd 2: Even	0 to 2	0	33	Parity:x	R/W	✓	✓
125	I16	Stop bit length	1, 2	1	34	Stopbit:x	R/W	✓	✓
126	I16	Incorporated terminating resistor 0: OFF 1: ON	0, 1	0	35	Term:x:x	R/W	✓	✓
127	I16	Loss of Modbus communication detection time (sec.)	0 to 300	0	36	Timeout:x	R/W	✓	✓

■ Description of Modbus setting

- Input select
Set whether analog input or position output command via Modbus communication
- Loss of Modbus communication detection time
0: None
1 to 300: Judges loss of communication when Modbus commands are not received for a set period of time or longer.
If a loss of communication occurs during operation with Modbus input, the output stem moves according to the settings of SW1-1 and 2.

1.8. Basic setting

MODBUS		ITEM	VALUE RANGE	STANDARD EX-FACTORY	PU-2x		R/W	SAVE	CFG
ADDRESS	TYPE				ITEM	DISPLAY			
131	I16	Full-open position (degree)	-2.0 to 92.0 (< full-close position)	90.0	40	OpnDeg:x	R/W	✓	✓
132	I16	Full-close position (degree)	-2.0 to 92.0 (> full-open position)	0.0	41	ClsDeg:x	R/W	✓	✓
133	I16	Deadband %	0.2 to 0.5	0.2	42	DBand:x	R/W	✓	✓
134	I16	Restart limiting timer (sec.)	0.1 to 5.0	0.1	43	Restart:x	R/W	✓	✓
135	I16	Full-open signal position %	75.0 to 100.0	98.0	44	OpnSig:x	R/W	✓	✓
136	I16	Full-close signal position %	0.0 to 25.0	2.0	45	ClsSig:x	R/W	✓	✓
137	I16	Operation speed	1 to 10	-	46	DBand:x	R/W	✓	✓

■ Description about basic setting

- Full-open / full-close position
Set the output stem position at 100%/0% input.
- Deadband
Set the deadband width with the stroke at the set full-open / full-close position as 100%.
- Restart limiting timer
To prevent the overheat of the motor, set an interval to restart when the motor stops on the deadband.
Using in a high-temperature atmosphere, set a longer restart limiting timer.
- Full-open / full-close signal position
Set the threshold at which the full-open / full-close signal is turned ON with the stroke at the set full-open / full-close position as 100%.

1.9. Linearization setting

MODBUS		ITEM	VALUE RANGE	STANDARD EX-FACTORY	PU-2x		R/W	SAVE	CFG
ADDRESS	TYPE				ITEM	DISPLAY			
161	I16	Linearization function 0: disabled, 1: enabled	0, 1	0	47	Linearize:x	R/W	✓	✓
162	I16	Number of points	2 to 50	3	–	–	R/W	✓	✓
163	I16	Input [1] (%)	-2.0 to +102.0	0.0	–	–	R/W	✓	✓
164	I16	Output [1] (%)	-2.0 to +102.0	0.0	–	–	R/W	✓	✓
165	I16	Input [2] (%)	-2.0 to +102.0	50.0	–	–	R/W	✓	✓
166	I16	Output [2] (%)	-2.0 to +102.0	50.0	–	–	R/W	✓	✓
167	I16	Input [3] (%)	-2.0 to +102.0	100.0	–	–	R/W	✓	✓
168	I16	Output [3] (%)	-2.0 to +102.0	100.0	–	–	R/W	✓	✓
169	I16	Input [4] (%)	-2.0 to +102.0	0.0	–	–	R/W	✓	✓
170	I16	Output [4] (%)	-2.0 to +102.0	0.0	–	–	R/W	✓	✓
:	I16	:	:	:	–	–	R/W	✓	✓
261	I16	Input [50] (%)	-2.0 to +102.0	0.0	–	–	R/W	✓	✓
262	I16	Output [50] (%)	-2.0 to +102.0	0.0	–	–	R/W	✓	✓

■ LINEARIZATION SETTING

MRP11 operates with linear characteristics in its standard state (relation between input signal and output stem), but it is possible to adjust the settings to different characteristics.

For example, it can be corrected to control characteristics such as an input signal of 12 mA (50%) resulting in an output axis operation angle of 27° (30%), and 20 mA (100%) resulting in 90° (100%). In fluid control, based on the relation between input values and flow rate (pressure, temperature, etc.), settings and changes can be made individually on the actuator without using a PC. Up to 50 points can be set, and the operation between each point is linear interpolation.

• In case of I/O characteristics of the above example

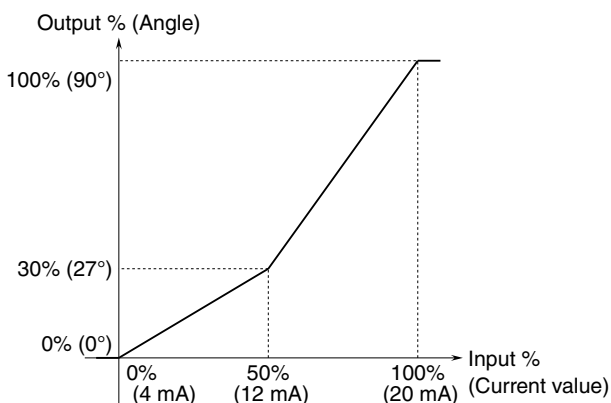

ITEM	SETTING VALUE
Linearization function	1
Number of points	3
Input [1] (%)	0.0
Output [1] (%)	0.0
Input [2] (%)	50.0
Output [2] (%)	30.0
Input [3] (%)	100.0
Output [3] (%)	100.0
Input [4] (%)	x.x
Output [4] (%)	x.x
:	:

• In case of I/O characteristics like V-shaped characteristics

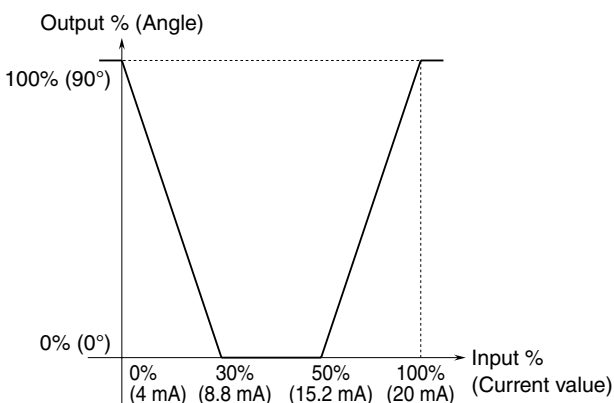

ITEM	SETTING VALUE
Linearization function	1
Number of points	4
Input [1] (%)	0.0
Output [1] (%)	100.0
Input [2] (%)	30.0
Output [2] (%)	0.0
Input [3] (%)	70.0
Output [3] (%)	0.0
Input [4] (%)	100.0
Output [4] (%)	100.0
Input [5] (%)	x.x
Output [5] (%)	x.x
:	:

Note: Within the range of the number of points (n) to be set, ensure that input [n] > input [n-1].

Any value is acceptable outside the range of the number of points.

COMBINATION OF OPERATION MODE AND SPECIFICATIONS

OPERATION MODE			OPERATION SPECIFICATIONS					
Manual operation	Input mode (*1)	Modbus operation mode (*3)	Output stem operation	SW1-5, 6	PU-2x		Modbus	
				Retract (UP) / Extend (DOWN)	Read data /Clear data command	Setting change	Read data /Clear data command (*7)	Setting change
OFF	Analog input	Monitor mode	Follows analog input (*5)	–	✓	–	✓	–
		Modbus input mode	Stops	–	✓	–	✓	–
		Configuration mode	Stops	–	✓	–	✓	✓
	Modbus input	Monitor mode	Stops	–	✓	–	✓	–
		Modbus input mode	Follows Modbus input (Address 101) (*6)	–	✓	–	✓	–
		Configuration mode	Stops	–	✓	–	✓	✓
ON	N/A (*2)	Monitor mode (*4)	Moves by button operation	✓	✓	✓	✓	–

*1 Configurable on PU-2x (ITEM 30) or via Modbus (Address 121).

*2 No difference between 'Analog input and 'Modbus input'.

*3 The mode is switched via Modbus (address 111).

*4 Turn SW1-8 ON to forcibly switch the Modbus input mode to Monitor mode.

*5 The output stem operates according to the settings of SW1-1 and 1-2 when abnormally low input is detected.

*6 The output stem operates according to the settings of SW1-1 and 1-2 when a Modbus disconnection error is detected.

*7 Includes writing to Modbus address 5 to 16, 51, 52, 101, and 111.

MAINTENANCE

For effective use and longer life of the Mini-Top electronic actuator, regular checking appropriate for its operating conditions are recommended. Refer to the following table.

ITEM	CHECKING POINT	HOW TO PROCEED
Stem operation	Apply input 0%, 50%, 100%, then back to 50%, 0%. Check that the actuator operates to the correct positions at respective input values.	Repair or calibrate the unit.
Abnormal sound	No abnormal sound is heard during operation.	Repair or calibrate the unit.
Water or rust inside the housing	Check that there is no water or rust inside the housing. If there is water inside, check the packing and the wiring cable connector is not loose.	Remove water and dry the housing and the parts inside. Replace rusted parts, if any. Replace the packing, if damaged. Re-tighten cable connector, if loose.
Screws	Check that screws and bolts are securely fastened.	Re-tighten them, if loose.

For repair or parts replacement, contact us or our representatives.

■ LUBRICATION

There is no need of greasing for the transmission gear mechanism inside the machinery.

■ REGULAR TEST RUNNING

If the valve is not frequently operated, run a test operation regularly (once a week, for example) to ensure that the actuator operates normally.

TROUBLESHOOTING

TROUBLE	LED				POSSIBLE CAUSE	HOW TO PROCEED
	POWER	INPUT	COM	ALARM		
Actuator does not work (Analog input)	OFF	–	–	–	Power failure Cable breakage	Check the power supply and cables.
	ON	OFF	–	–	Input error	Check the input signal level.
	ON	ON	–	–	Mode is set to Manual operation or Modbus input mode.	Check the operation mode.
	ON	ON	–	ON	Motor deadlock error	Apply input in reverse direction.
Actuator does not work (Modbus input)	ON	–	OFF	–	Modbus communication is not established.	Check the communication cable. Check the Node address. Check the baud rate.
	ON	–	Blinks	–	Mode is set to Manual operation or Analog input mode.	Check the operation mode.
	ON	–	–	ON	Motor deadlock error	Clear error via Modbus. Turn SW1-8 ON and then OFF.
Unstable operation	–	–	–	–	Abnormal power voltage, Noise	Check power voltage and noise in input signal.

LIGHTNING SURGE PROTECTION

We offer a series of lightning surge protectors for protection against induced lightning surges. Please consult us to choose appropriate models.