

MINI-TOP ELECTRONIC ACTUATOR
(rotary type)

MODEL **MRP4/MRP5**
/MRP6

BEFORE USE

Thank you for choosing us. Before use, please check contents of the package you received as outlined below. If you have any problems or questions with the product, please contact our sales office or representatives.

■ PACKAGE INCLUDES:

Mini-Top(1)

The Mini-Top is not provided with a yoke or other components required for mounting it to a valve. They are to be provided by the user.

■ MODEL NO.

Confirm Model No. marking on the product to be exactly what you ordered.

POINTS OF CAUTION

■ CONFORMITY WITH EU DIRECTIVES AND UK LEGISLATION

- This equipment is suitable for Pollution Degree 2 and Measurement Category II (Full-open/-closed signal, transient voltage 1500V). Reinforced insulation (Full-open/-closed signal to other, power or metallic housing: 125V) is maintained. Prior to installation, check that the insulation class of this unit satisfies the system requirements.
- Refer to our website for more information about the legislations and designated standards of UKCA.
- Altitude up to 2000 meters.
- The equipment must be installed such that appropriate clearance and creepage distances are maintained to conform to CE and UKCA requirements. Failure to observe these requirements may invalidate the CE and UKCA conformance.
- Install lightning surge protectors for those wires connected to remote location. Refer to "LIGHTNING SURGE PROTECTION" section below.

■ POWER INPUT RATING & OPERATIONAL RANGE

- Locate the power input rating marked on the product and confirm its operational range as indicated below:
100 – 120V AC rating: 90 – 132V, 47 – 66 Hz, approx. 25VA
200 – 240V AC rating: 180 – 264V, 47 – 66 Hz, approx. 25VA
24V DC: 24V rating ±10%, approx. 0.6A
- A fuse of the following rating is incorporated: 250V/1A time delay.
- A rush current 1.5 times as high as the above ratings can flow at the startup.

■ GENERAL PRECAUTIONS

- Remove the power supply to the actuator before wiring to it.

■ INSTALLATION

- Indoor, or outdoor where the MRP is NOT exposed to direct sunlight.
- Ambient temperature: -5 to +55°C (23 to 131°F)
- Operating humidity 30 to 85% RH (non-condensing)
- Vibration: 0.5 G (4.9 m/s²) max.
- Install the MRP where you can reach for maintenance.

Observe at the minimum of 15 centimeters (6 inches) above the cover.

■ OUTDOOR USE

- When installing the MRP outdoor or where it is exposed to rain or water drops, be sure to fasten the cable connector tightly and leave a slack of the cable.
- Do not mount the MRP in such direction that the output stem or cable connector is at the top of the MRP unit.

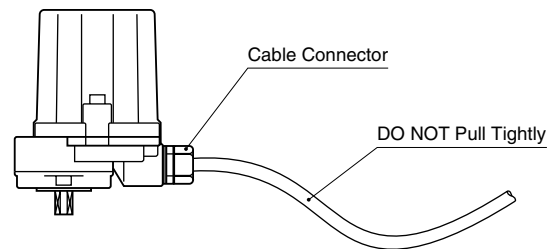

■ ELECTRICAL CONNECTION

- With DC power type unit, power supply and signal lines are not isolated. Use an isolator if needed.
- When you use a cable other than the standard 1-meter cable equipped with non-terminal box type unit and its extension distance is longer than that, use shielded cables for signal line, or install signal cables in a separate piping from power supply cables.

■ LIGHTNING SURGE PROTECTION

- In order to protect the unit from lightning surges entering through cables, use of appropriate lightning surge protectors are recommended. For 24V DC power supply line, choose a surge protector with its maximum surge voltage 40V or less between lines. Recommended model: MDP-D24.

■ PID CONTROLLER

- Choose PID parameters carefully so that the MV remains as stable as possible. Unstable operations shorten the life of actuator and valve.

■ O-RING, GASKET

- When replacing the actuator cover after adjustments, check that the O-ring is securely placed in the groove.
- When replacing the terminal box cover, check that the gasket is in place.

■ YOKE DESIGN

- When a foreign object is caught in the valve, a torque 2 times greater than the maximum rating could be generated. Leave enough strength for mechanical components such like the yoke and stem.
- If the MRP is used on a steam line in temperature control, it is possible that the MRP's temperature rises higher than the ambient temperature due to transmission or radiation via the steam piping, even when the ambient temperature is within allowable range. Use a longer yoke to increase heat dissipation and apply insulating material.

■ AND

- DO NOT loosen the screw fixing the potentiometer stem. Loosening it could cause a malfunction.

- DO NOT step onto the actuator. DO NOT rest a heavy object on or against it.

PROTECTIVE FUNCTIONS

■ OVERLOAD (LOCK) PROTECTION

The MRP is equipped with a protection circuit against overload cause by for example valve catching an alien substance. When an overload is detected, the MRP stops supplying power to the motor and the status LED blinks in 0.5 sec. intervals.

The protection is reset automatically with applying opposite-direction input signal or turning power off and restarting.

A foreign object caught in the valve, inappropriate adjustments, ground screw of the valve tightened too much, etc. are some of the causes of overload. Check these parts and remove the cause of trouble for ensuring proper life of the actuator.

■ FUSE

A fuse is equipped for protection against overload current. When you turn the power supply on, check that the power LED is on. If it is off, check that the fuse is melted. Replace it with a new one.

If the new fuse is melted again soon after it has been replaced, there may be problems with the control PCB or the motor. Contact us or sales representative.

■ RE-STARTING TIMER

The MRP is equipped with a timer circuit which gives an interval period (0 – 10 sec.) between stop-restart actions to prevent the motor and other internal components from overheating.

It is recommended to set a long restarting time when the ambient temperature and/or the temperature of flow material is high.

COMPONENT IDENTIFICATION

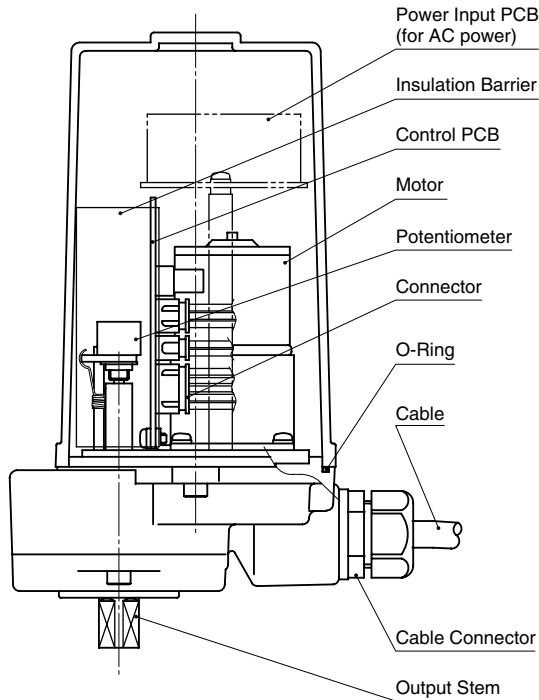

Figure 1. MRP4 & MRP5 Component Identification

Note: Construction of the MRP5 is partly different from the above figure.

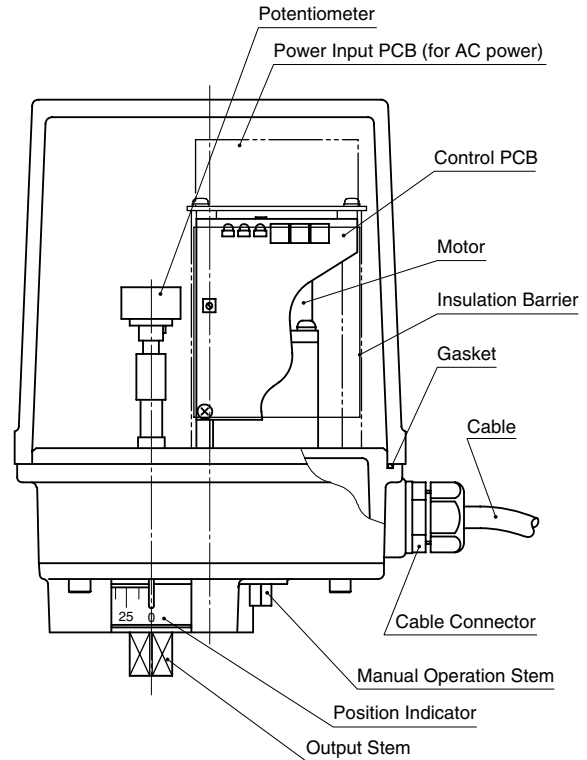
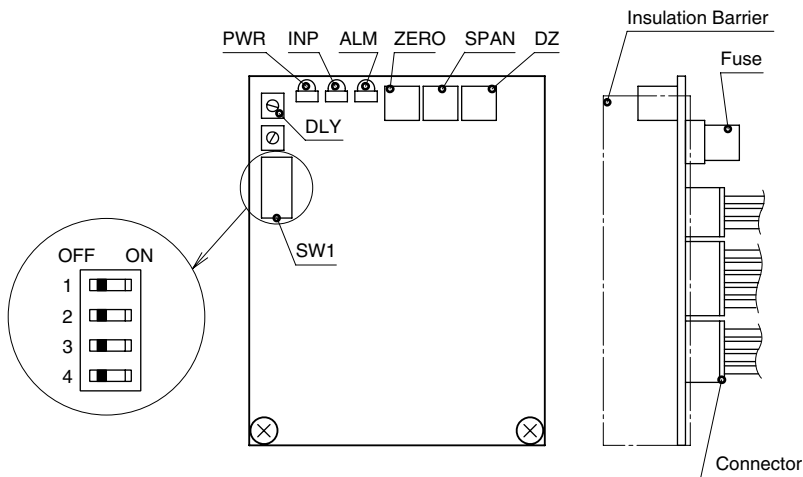

Figure 2. MRP6 Component Identification

Note: MRP6 is equipped with manual operation stem and position indicator. Turn the stem in counterclockwise as viewed from the top of the actuator to close the valve (reverse action). Turn it slowly with a 6 mm-width wrench (Operation torque ≤ 9 N·m).



- ZERO : Zero Adjustment
- SPAN : Span Adjustment
- DZ : Deadband Adjustment
- DLY : Restarting Timer
- SW1 : Direct/Reverse Actions,
Operation at Abnormally Low Input
- PWR : Power Indicator (green with power supplied)
- INP : Input Indicator (green with input applied)
- ALM : Status Indicator (red blinks in 2 sec. intervals,
blinks in 0.5 sec. intervals with mechanical lock detected)

Note: Turning adjustment potentiometers and switches with a torque exceeding their tolerance may destroy their stoppers. Turn them carefully and stop where they hit the stoppers. Be careful especially with Re-starting timer adjustment.

Figure 3. MRP Control PCB Identification

OUTPUT SPAN ADJUSTABILITY

The servo-control circuit compares and amplifies input signal (setpoint) and feedback signal from a potentiometer, and drives the motor to such direction to minimize difference of the two signals.

The general operational range is 0 – 90 deg. or 0 – 180 deg. with a 5-deg. margin at both limits. See Figure 5.

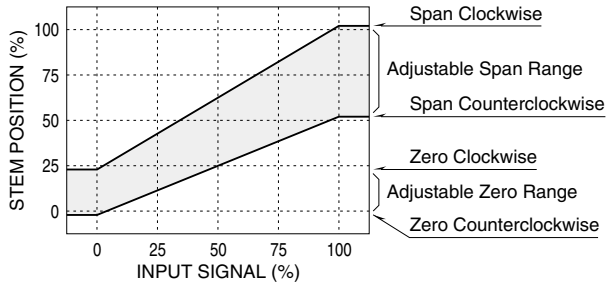

Figure 4. I/O Characteristics (Adjustable Range)

Table 1. Available Span Range for Each Model

MODEL	MIN. SPAN	MAX. SPAN
MRP4-1 MRP5-1 MRP6-1	45°	90°
MRP4-2 MRP6-2	90°	180°

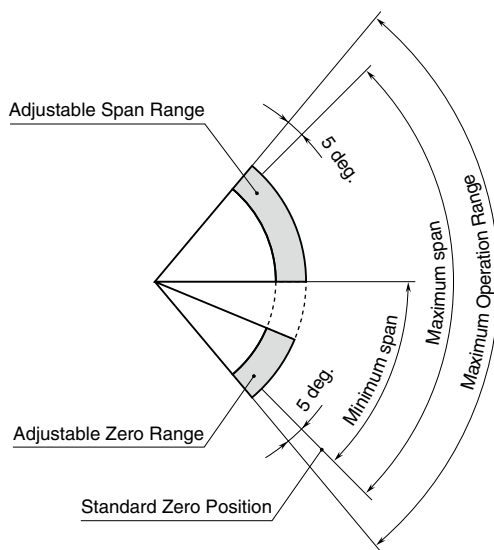

Figure 5. Minimum & Maximum Span

INSTALLATION

The following is a general procedure for mounting the MRP to a valve with a yoke and coupling.

Be sure NOT TO CHANGE factory adjusted setting of the MRP.

Remove power supply during the procedure unless otherwise specified.

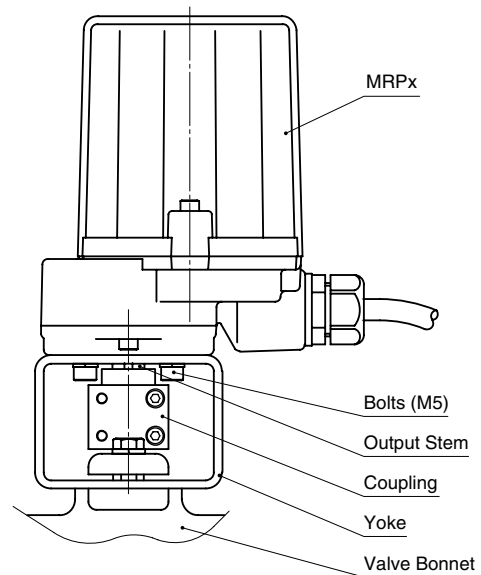
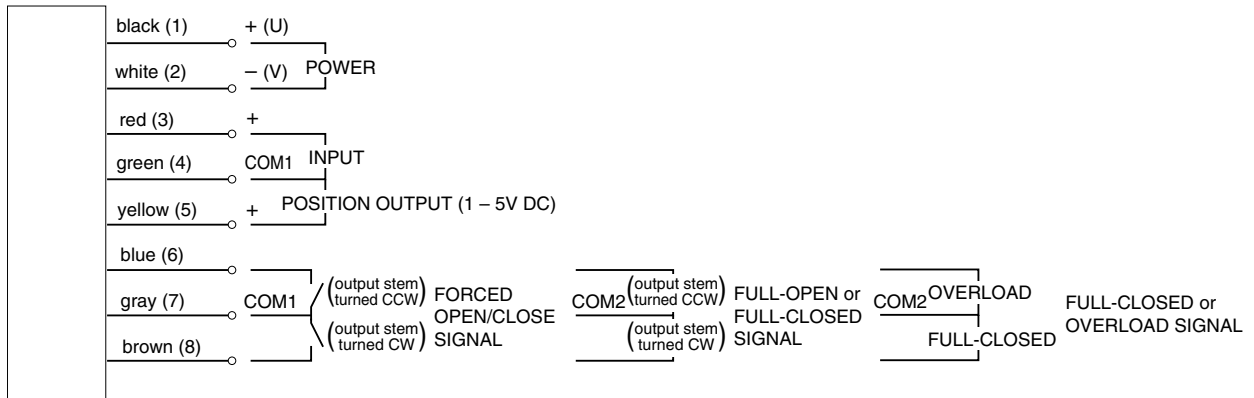

Figure 6. Example of the MRP Mounted to a Valve

- 1) Supply power to the MRP and apply 0% input (100% for direct action). Turn the output stem fully clockwise (seen from the cover).
- 2) Turn the valve stem to fully closed position (fully clockwise).
- 3) Set the yoke to the MRP.
- 4) Set the coupling to the valve stem and fit the MRP output stem into the coupling. Then fix the yoke and valve temporarily.
- 5) Fix the coupling so that there is no eccentricity between both stems.
- 6) Fix the yoke and valve firmly after checking the eccentricity of both stems again.
- 7) Attach the position indicator if required.

WIRING CONNECTION

Refer to the following diagram when wiring. If an optional terminal box is provided, remove its cover and connect leadwires.



(1) to (8): Terminal No. of terminal box.

Full-open/closed signals and forced open/close signals are optional.

Full-closed/overload signals are optional only for model: MRP4.

• With Both Full-open/closed Signal and Forced Open/Close Signal

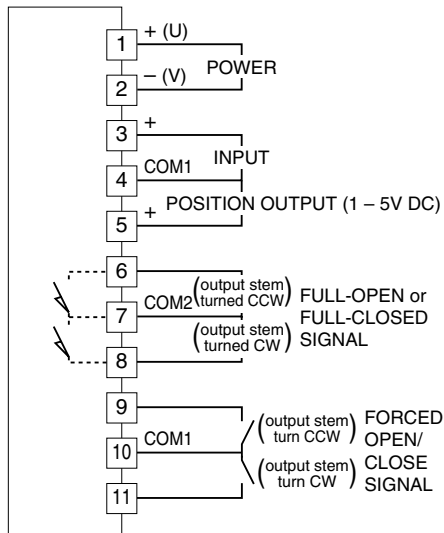

Figure 7. Wiring Diagram

Note: The yellow wire must be left unconnected if the position output signal is not required. Cut the exposed section of copper wire and insulate the tip of the wire.

■ WIRING INSTRUCTIONS FOR TERMINAL BOX OPTION

• Sequential Control Signal Suffix Code B

Applicable wire size 1.25 mm²

Remove insulation by 10 mm.

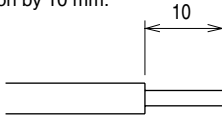

• Other Terminal Box Type

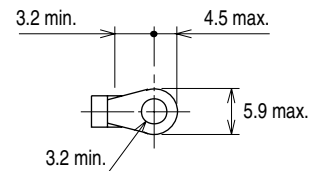

ADJUSTMENT PROCEDURE

Open the cover and adjust ZERO, SPAN, DZ (deadband), DLY (re-starting timer) potentiometers and the direct/reverse SW on the control PCB as shown in Figure 3.

Other adjustments which are paint locked are for factory use only and should be changed only by qualified our personnel. We are not liable for any malfunction or inconvenience caused by unauthorized change of them by the user.

■ DIRECT/REVERSE ACTION

The actuator action is factory set to “Reverse” (the output stem, seen from the cover, turns counterclockwise, with an input signal increase). For changing the setting, use the DIP SW on the control PCB. Refer to Tables 2 and 3.

Table 2. Switching Actions

ACTION	SW1-3	EXPLANATIONS*1
Direct	ON	Output stem turns CW with an input increase.
Reverse	OFF	Output stem turns CCW with an input increase.

Table 3. Operations at Abnormally Low Input

OPERATION*1	SW1-1	SW1-2
Stop	*2	ON
Clockwise	OFF	OFF
Counterclockwise	ON	OFF

*1. Seen from the cover.

*2. Whatever setting for SW1-1 is disregarded for Stop mode.

Note 1: SW1-4 is not used.

Note 2: With the direct action, the position output is 5 – 1V DC proportional to the input 0 – 100%.

■ GENERAL

After installing the valve and actuator, go to adjustments in order of zero, span, and sensitivity (deadband). If optional limit switches are provided, adjust them at the last.

The following explanation applies to reverse action For direct action, read the value in the brackets [].

Note: Applying an over-torque to the adjustments may destroy stoppers or other sections of them. Use a small-sized screwdriver and be sure to stop turning as soon as they hit the stoppers.

■ ADJUSTMENT PROCEDURE

A) Zero and Span

- Apply power supply voltage and 0% [100%] input. Turn ZERO adjustment until the output stem reaches an appropriate fully-clockwise position.
- Apply 100% [0%] input. Turn SPAN adjustment until the output stem reaches an appropriate fully-counterclockwise position.
- With 0% [100%] input again, check that the output stem is at the appropriate angle. If the position is shifted, go through the above procedure again.

Note: There is only minimal effect of span adjustment to zero point, thus the stem position shifts very little at the extended side when the span potentiometer is turned.

B) Sensitivity (Deadband)

When the motor repeats small inverting movements without stopping still for small input changes, widen the deadband by turning the DZ adjustment clockwise.

C) Limit Switches (optional)

Loosen the screws and adjust positions of the dogs. See Figure 8.

This adjustment cannot be done in an intermediate position of the valve. Set it at the fully open or closed position.

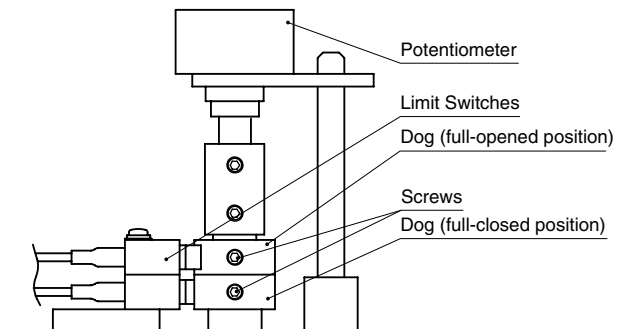

Figure 8. Limit Switches

MAINTENANCE

For effective use and longer life of the MRP, regular checking appropriate for its operating conditions are recommended. Refer to the following table.

ITEM	CHECKING POINT	HOW TO PROCEED
Functioning	Apply input 0%, 50%, 100%, then back to 50%, 0%. Check the actuator operations and positions at each input value.	Repair or calibration
Abnormal sound	No abnormal sound is heard during operation.	Repair or calibration
Connector Leadwire	The connector is firmly connected. No breakdown of leadwires. The insulation covers are not torn, not bruised.	Repair or calibration
Inside humidity, rust	No condensation. No rust. If there is water inside, check the packing.	Remove water, dry the case and inside parts. Replace rusted parts. Calibration. If the packing is damaged, replace it.
Screws	Check that screws and bolts are securely fastened.	Re-tighten them.

For repair or parts replacement, contact us or representatives.

■ LUBRICATION

There is no need of oiling the MRP in normal operating conditions.

■ REGULAR TEST RUNNING

If the valve is not frequently operated, run a test operation regularly (once a week, for example) to check proper functions.

TROUBLESHOOTING

TROUBLE	POWER LED	INPUT LED	STATUS LED	POSSIBLE CAUSE	HOW TO PROCEED
No function	ON	ON	Blink 2 sec	Abnormal input signal. (No change over deadband)	Check input signal. Narrow the deadband.
	ON	----	Blink 0.5 sec	Actuator mechanism is damaged.	Repair
				Overload cause by a foreign object caught in the valve.	Check the valve.
				Control PCB damaged.	Repair or replace.
				Wiring error at the motor or position sensor.	Check the connector.
				Low power voltage or insufficient capacity.	Check the power supply.
	ON	OFF	Blink 2 sec	Abnormal input signal.	Check the input signal.
				Wiring error at the input signal.	Check the connector and connecting section.
	OFF	----	----	Wiring error at the power supply.	Check the connector and connecting section.
				Abnormal power supply voltage.	Check the power supply.
				Fuse melted.	Replace the fuse.
	ON	----	ON	Malfunction by noise.	Turn off the power supply and restart.
				Low power voltage or insufficient capacity.	Check the power supply.
ON	----	OFF	Malfunction by noise.	Turn off the power supply and restart.	
Unstable functioning				Low power voltage or insufficient capacity.	Check the power supply.
				Power voltage is low or fluctuating.	Check the power supply.
				Unstable input signal.	Check the controller, cables. Eliminate noise.
Stops in the middle of span Slows down in the middle of span				Position sensor damaged.	Replace the position sensor.
				Actuator mechanism is damaged.	Repair
				Overload cause by a foreign object caught in the valve.	Check the valve.

---- Regardless of LED state.

For repair or parts replacement, contact us or representatives.

LIGHTNING SURGE PROTECTION

We offer a series of lightning surge protectors for protection against induced lightning surges. Please contact us to choose appropriate models.