

CONTENTS

1. BEFORE USE	2
2. POINTS OF CAUTION.....	2
3. COMPONENT IDENTIFICATION	3
4. OUTPUT SPAN ADJUSTABILITY	4
5. INSTALLATION	4
6. WIRING CONNECTION	5
7. COMMUNICATION CABLE CONNECTIONS.....	5
8. ADJUSTMENT PROCEDURE.....	5
8.1. MANUAL OPERATION	5
8.1.1. ZERO & SPAN.....	6
8.1.2. DEADBAND	6
8.1.3. RESTART LIMITING TIME	6
8.1.4. COMMUNICATION ERROR OPERATION.....	6
8.2. CC-Link.....	6
8.2.1. STATION NO.....	6
8.2.2. BAUD RATE	6
8.2.3. COMMUNICATIONS	7
8.2.4. BASIC OPERATING PROCEDURE.....	8
9. MAINTENANCE.....	8
10. TROUBLESHOOTING	8
11. LIGHTNING SURGE PROTECTION	8

1. BEFORE USE

Thank you for choosing us. Before use, please check contents of the package you received as outlined below.

If you have any problems or questions with the product, please contact our sales office or representatives.

■ PACKAGE INCLUDES:

Mini-Top	(1)
Replaceable fuse*	(1)
Terminating resistor (110 Ω, 0.5 W)*	(1)

* Inside the terminal box

The Mini-Top is not provided with a yoke or other components required for mounting it to a valve. They are to be provided by the user.

■ MODEL NO.

Confirm Model No. marking on the product to be exactly what you ordered.

2. POINTS OF CAUTION

■ POWER INPUT RATING & OPERATIONAL RANGE

- Locate the power input rating marked on the product and confirm its operational range as indicated below:
24V DC: 24V rating $\pm 10\%$, approx. 0.7A

■ GENERAL PRECAUTIONS

- Remove the power supply to the actuator before wiring to it.

■ INSTALLATION

- Indoor, or outdoor where the MRPxC2 is NOT exposed to direct sunlight
- Ambient temperature: -5 to +55°C (23 to 131°F)
- Operating humidity: 30 to 85% RH (non-condensing)
- Vibration: 0.5 G (4.9 m/s²) max.
- Install the MRPxC2 where you can reach for maintenance. Observe at the minimum of 15 centimeters (6 inches) above the cover.

■ ELECTRICAL CONNECTION

- Separate the cables (power supply and communications) from other cables to prevent surge or inductive interference.
- Do not bind these cables together with mains supply cables or high-voltage cables. Do not install them in the same duct.

■ OUTDOOR USE

- When installing the MRPxC2 outdoor or where it is exposed to rain or water drops, be sure to fasten the cable connector tightly and leave a slack of the cable.
- Do not mount the MRPxC2 in such direction that the output stem is at the top of the Mini-Top unit.

■ O-RING, PACKING

- After adjustments, check that the O-ring for the terminal box is securely placed in the groove. There is no need to remove the Mini-Top unit cover for adjustment. DO NOT remove the cover.

■ YOKE DESIGN

- When a foreign object is caught in the valve, a torque 1.5 times greater than the maximum rating could be generated. Leave enough strength for mechanical components such like the yoke and joint.
- If the MRPxC2 is used on a steam line in temperature control, it is possible that the MRPxC2 temperature rises higher than the ambient temperature due to transmission or radiation via the steam piping, even when the ambient temperature is within allowable range.
Use a longer yoke to increase heat dissipation and apply insulating material.

■ AND

- DO NOT loosen the screw fixing the potentiometer stem. Loosening it could cause a malfunction.
- DO NOT step onto the actuator. DO NOT rest a heavy object on or against it.

3. COMPONENT IDENTIFICATION

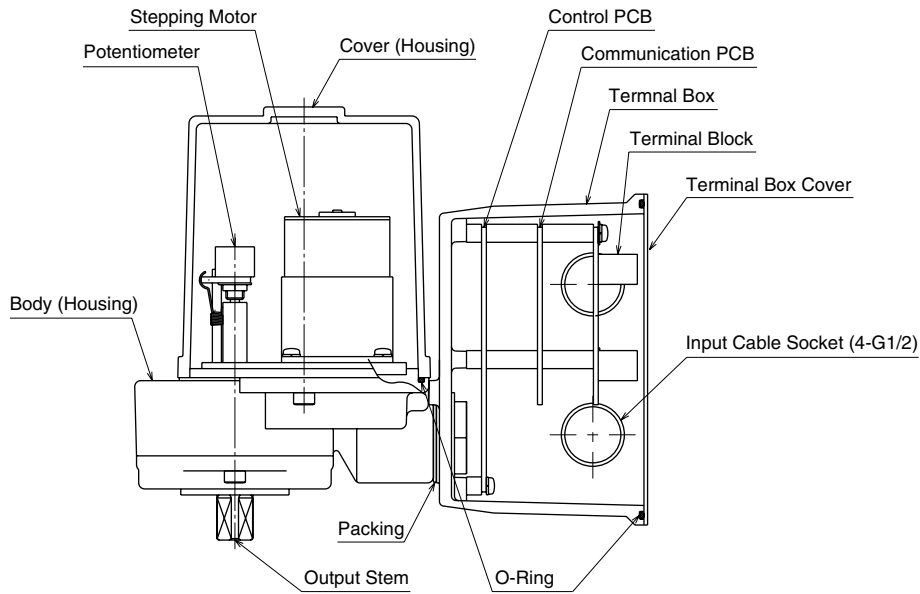

Figure 1. Component identification: MRP4C2, MRP5C2

Note: Construction of the MRP5C2 is partly different from the above figure.

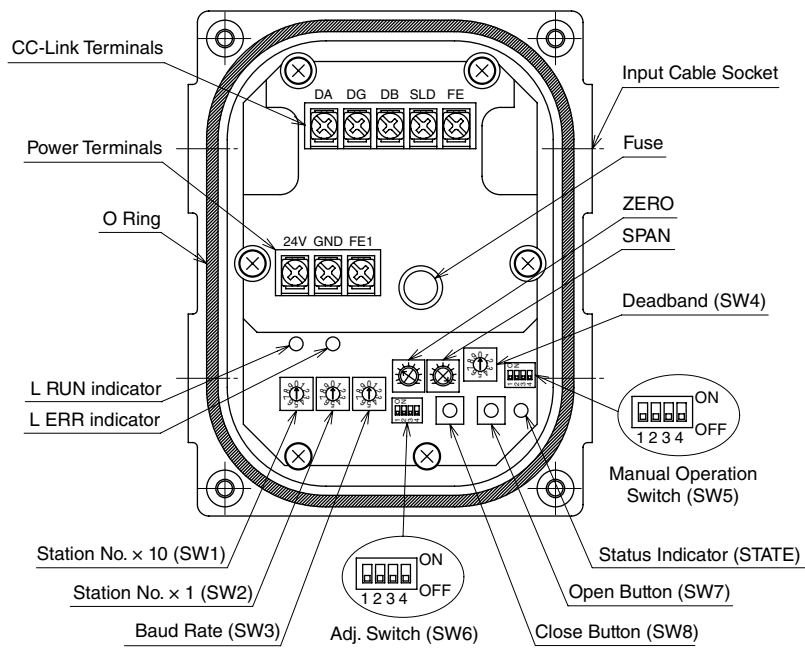

Figure 2. Component identification, Communication Box

Note: Turning adjustment potentiometers and switches with a torque exceeding their tolerance may destroy their stoppers. Turn them carefully and stop where they hit the stoppers.

■ STATUS INDICATOR LED

Normal status: Blinks with 2 sec. frequency
 Output Stem deadlock: Blinks with 0.5 sec. frequency
 PCB failure: ON or OFF continuance.

■ COMMUNICATION MONITOR INDICATOR LED

ID	STATUS	FUNCTION
L RUN	ON	Communicating
	Blink	----
	OFF	Not entering the network yet Timeout
L ERR	ON	CRC error Switch configuration error detected when the power was turned on.
	Blink	Switch configuration has been altered after the power was turned on.
	OFF	Normal

4. OUTPUT SPAN ADJUSTABILITY

The servo-control circuit compares and amplifies the target position signal and the feedback signal from the potentiometer, and drives the motor to such direction to minimize difference of the two signals.

Typical span is 0 to 90° or 0 to 180°, with 3° adjustability for both directions as shown in Figure 4.

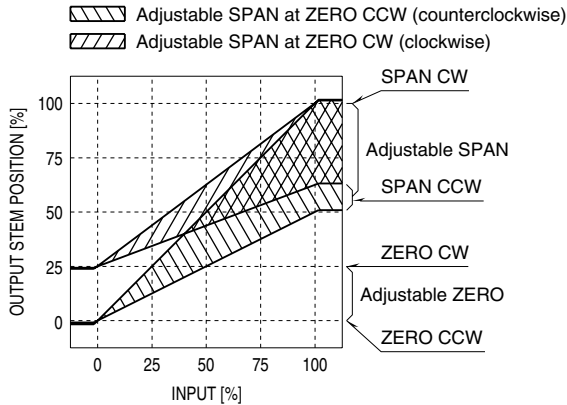

Figure 3. I/O characteristics (adjustable range)

The Span, with the Zero turned fully counterclockwise, is adjustable from 50% to 100%. With the Zero turned gradually clockwise, the Span's adjustable range become narrower, down to 62.5 – 100%. The Span is adjustable to 50 – 100% of the remaining total stroke after the Zero adjustment.

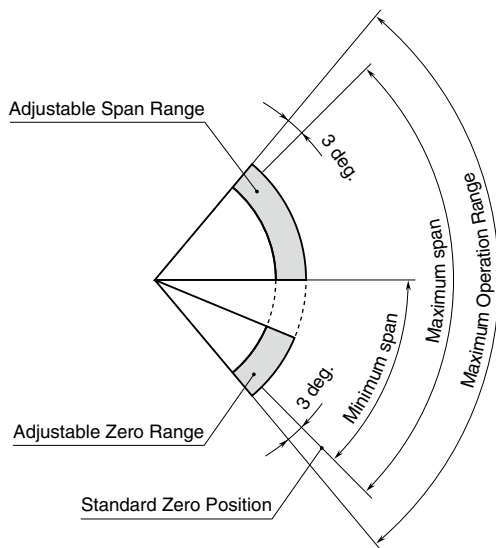

Figure 4. Definition of the minimum and maximum spans

Table 1. Minimum and Maximum spans

MODEL	MIN. SPAN	MAX. SPAN
MRP4C2-1	45°	90°
MRP5C2-1		
MRP4C2-2	90°	180°

5. INSTALLATION

The following is a general procedure for mounting the MRPxC2 to a valve with a yoke and coupling.

Be sure NOT TO CHANGE factory adjusted setting of the MRPxC2.

Remove power supply during the procedure unless otherwise specified.

- 1) Supply power to the actuator, apply 0% (100% for direct action) input signal and manually control the actuator stem to the fully-clockwise position (seen from the cover).
- 2) Push in the valve stem at the fully-clockwise position.
- 3) Set the yoke to the actuator.
- 4) Set the joint to the valve stem, fit the actuator stem into the joint and temporarily fix the yoke and valve.
- 5) Fix the joint position and match the centers of actuator stem and valve stem.
- 6) Check the centers of actuator stem and valve stem again and fix the yoke and the valve firmly.

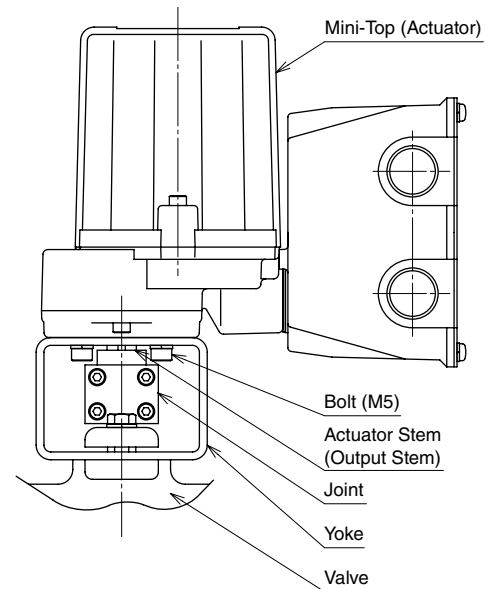
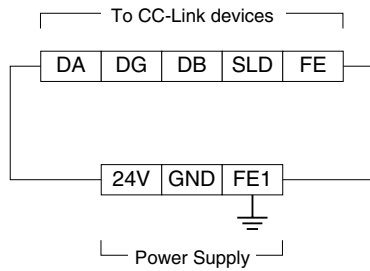

Figure 5. Mini-Top mounted onto a valve (example)

6. WIRING CONNECTION

■ CC-Link CONNECTOR

- Use a cable approved for CC-Link. (Compatible with CC-Link Ver. 1.10)
- Use a shielded cable for power supply.



■ SOLDERLESS TERMINAL FOR M3 SCREW unit: mm (inch)

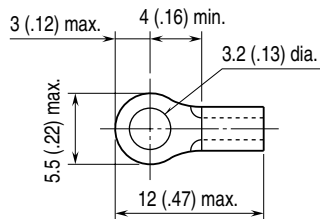

7. COMMUNICATION CABLE CONNECTIONS

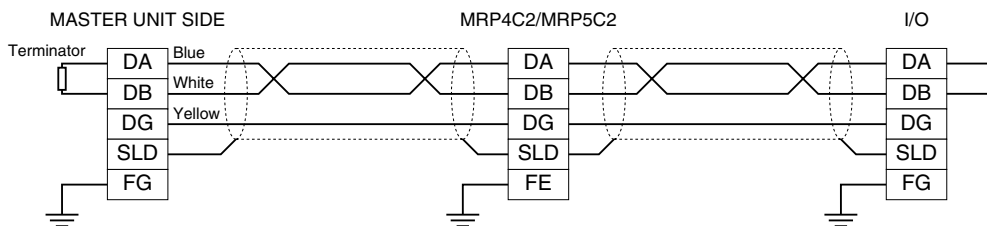

8. ADJUSTMENT PROCEDURE

8.1. MANUAL OPERATION

The MRPxC2 can be manually controlled regardless of the communications status. Turn the SW5-1 ON to enable the manual operation mode. The SW8 and SW7 are used for control.

In the following explanations, “0%” refers to the fully clockwise (seen from the cover) stem position adjusted with the Zero; while “100%” refers to the fully counterclockwise stem position adjusted with the Span.

Table 2. SW5 setting, manual operation

SW5	OFF	ON
1	Control via communications	Manual operation
2	Invalid	0% manual control command
3	Invalid	100% manual control command
4	Unused	

Turning both SW5-2 and -3 are invalid. The actuator operation stops.

SW8: The stem moves toward 0% position while pressing this switch.

SW7: The stem moves toward 100% position while pressing this switch.

8.1.1. ZERO & SPAN

1) Zero Adjustment: Turn the power supply on and set the SW5-1 and -2 ON (OFF for the others on the SW5). This turns the actuator into the manual operation mode and automatically controls the stem toward the 0% position.

Once the stem reaches the position, adjust the Zero potentiometer so that the stem reaches the desired clockwise position.

2) Span Adjustment: Turn the power supply on and set the SW5-1 and -3 ON (OFF for the others on the SW5). This turns the actuator into the manual operation mode and automatically controls the stem toward the 100% position.

Once the stem reaches the position, adjust the Span potentiometer so that the stem reaches the desired counter-clockwise position.

3) With 0% input again, check that the Mini-Top is at the fully clockwise position. If the position is shifted, go through the above procedure again.

Note 1: There is only minimal effect of span adjustment to zero point, thus the stem position shifts very little at the fully clockwise side when the span potentiometer is turned.

Note 2: With a narrower operating range, hunting (the motor repeats changing direction) can happen more often. Adjust Deadband in such cases.

8.1.2. DEADBAND

'Deadband' is provided in 0.2% increments from 0.1%, 0.3%, 0.5%, with the fractions dropped.

SW4	DEADBAND (%)
0	0.1
1	0.3
2	0.5
3	0.7
4	0.9
5	1.1
6	1.3
7	1.5 (*)
8	1.7
9	1.9

(*) Factory setting

8.1.3. RESTART LIMITING TIME

Set the restart limiting time as follows:

SW6-1	SW6-2	RESTART LIMITING TIME (sec.)
OFF	OFF	0
ON	OFF	1.5 (*)
OFF	ON	5
ON	ON	10

(*) Factory setting

8.1.4. COMMUNICATION ERROR OPERATION

The actuator operation in case of a communication error once normal communication is established after the power is turned on is defined as follows:

SW6-3	SW6-4	COMM. ERROR OPERATION
OFF	OFF	Stop
ON	OFF	0% position
OFF	ON	100% position
ON	ON	Stop

8.2. CC-Link**8.2.1. STATION NO.**

Set the upper digit (x10) with SW1 and the lower digit (x1) with SW2.

This device occupies one station.

8.2.2. BAUD RATE

The baud rate is selected with the SW3.

SW3	BAUD RATE
0	156 kbps
1	625 kbps
2	2.5 Mbps
3	5 Mbps
4	10 Mbps

All other settings are invalid.

8.2.3. COMMUNICATIONS

■ MASTER to SLAVE

DATA TYPE	ADDRESS	FUNCTION	DETAIL
Bit	RY0	Forced Closed Position Input*1	0 : Disable 1 : Position = 0%
	RY1	Forced Open Position Input*1	0 : Disable 1 : Position = 100%
	RY2		
	RY3		
	RY4		
	RY5		
	RY6		
	RY7		
	RY8	Enable Target Position Input	0 : Disable 1 : Enable
	RY9		
	RYA	Reset Motor Deadlock Alarm	Motor deadlock alarm is canceled when '1' is set.
	RYB	Clear Motor Starting Counter	Motor starting counter is reset to 0 when '1' is set.
	RYC	Clear Motor Reversing Counter	Motor reversing counter is reset to 0 when '1' is set.
	RYD	Clear Accumulated Running Distance	Accumulated running distance is reset to 0 when '1' is set.
	RYE		
	RYF		
Word	RWw0	Target Position Input	Signed, 0.01% increments (e.g. 100 = 1.00%) Valid only when Enable Target Position Input is enabled.
	RWw1		
	RWw2		
	RWw3		

*1. Valid regardless of the RY8 (Enable Target Position Input) status. Stopped when '1' is set both at RY0 and RY1.

■ SLAVE to MASTER

DATA TYPE	ADDRESS	FUNCTION	DETAIL
Bit	RX0		
	RX1		
	RX2		
	RX3		
	RX4		
	RX5		
	RX6		
	RX7		
	RX8	Motor Deadlock Alarm	0 : Normal 1 : Overload or other deadlock alarm
	RX9	Target Position Input Error	0 : Normal 1 : Out of range from -0.5 to +100.5%
	RXA	System Error	0 : Normal 1 : Memory or other system error
	RXB	Control Status	0 : Remote (CC-Link) 1 : Manual
	RXC		
	RXD		
	RXE		
	RXF		
Word	RWr0	Position Output	Signed, 0.01% increments (e.g. 100 = 1.00%)
	RWr1	Motor Starting Counter *2	1 count per every 100 starting actions
	RWr2	Motor Reversing Counter *2	1 count per every 100 reversing actions
	RWr3	Accumulated Running Distance (%) *2	1 count per running 100% distance every time

*2. When the count reaches 65535, the value is held until it is reset.

8.2.4. BASIC OPERATING PROCEDURE

(1) Normal Operation

Once the communication is established, the actuator can be operated only by setting 'Enable Target Position Input' (RY8) to '1' and providing 'Target Position Input' value (RWw0).

Target Position Input data is described by signed 16-bit data, representing 0.01% by 1 LSB.

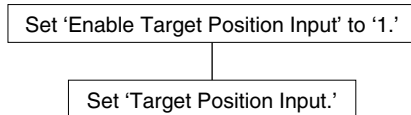

For example, set '5000' in binary for 50% setpoint. Set '-50' for -0.5%. Binary must be 2's complement. 'Position Output' (RWr0) data is in the same format.

(2) Motor Deadlock Alarm

When the motor is overloaded or stuck with a foreign object, the actuator sets '1' to 'Motor Deadlock Alarm' (RX8) and stops.

When '1' is set to 'Reset Motor Deadlock Alarm' (RYA), the actuator restarts.

Be sure to confirm that the Motor Deadlock Alarm is reset to '0' before returning Reset Motor Deadlock Alarm to '0.'

(3) Operation Report

The following data can be read out for maintenance purposes: Motor Starting Counter, Motor Reversing Counter and Accumulated Running Distance.

These data are stored in the nonvolatile memory every 10 minutes and are not deleted even when the power is removed.

In order to reset these data to 0, set '1' to the respective reset commands (RYB to RYD).

Return the reset signals to '0' after the data resetting has been confirmed.

9. MAINTENANCE

For effective use and longer life of the Mini-Top, regular checking appropriate for its operating conditions are recommended. Refer to the following table.

ITEM	CHECKING POINT	HOW TO PROCEED
Functioning	Apply input 0%, 50%, 100%, then back to 50%, 0%. Check the actuator operations and positions at each input value.	Repair or calibration
Abnormal sound	No abnormal sound is heard during operation.	Repair or calibration
Inside humidity, rust	No condensation. No rust. If there is water inside, check the packing. Check that the wiring cable connector is not loose.	Remove water, dry the case and inside parts. Replace rusted parts. If the packing is damaged, replace it. Re-tighten it.
Screws	Check that screws and bolts are securely fastened.	Re-tighten them.

For repair or parts replacement, contact us or representatives.

■ LUBRICATION

There is no need of oiling the Mini-Top in normal operating conditions.

■ REGULAR TEST RUNNING

If the valve is not frequently operated, run a test operation regularly (once a week, for example) to check proper functions.

10. TROUBLESHOOTING

TROUBLE	L RUN	L ERR	POSSIBLE CAUSE	HOW TO PROCEED
No Function	ON	OFF	Normal communication?	Confirm that the manual operation is possible.
	ON	Blink	Station No. and/or Baud rate has been changed after the power supply has been turned on.	Turn the power supply off and on.
	OFF	OFF	Power source is turned off or cable broken.	Check the power source and the cables.
	--	ON	Station No. and/or Baud rate error detected when the power supply has been turned on. Communication error	Correct the Station No. and/or Baud rate setting. Check noise possibilities. Check the terminating resistor.
Unstable functioning			Power voltage is low or fluctuating.	Check the power supply.
			Position sensor damaged.	Replace the position sensor.
Stopped in the middle of stroke Slows down in the middle of stroke			Actuator mechanism is damaged.	Repair.
			Overload caused by a foreign object caught in the valve.	Check the valve.

11. LIGHTNING SURGE PROTECTION

We offer a series of lightning surge protectors for protection against induced lightning surges. Please contact us to choose appropriate models.