

**CONTENTS**

1. BEFORE USE .....	2
2. POINTS OF CAUTION.....	3
3. COMPONENT IDENTIFICATION .....	4
4. STATUS INDICATOR LED AND SIDE DIP SWITCH .....	5
5. WIRING CONNECTION .....	6
6. COMMUNICATION CABLE CONNECTIONS.....	6
7. OUTPUT STEM STROKES.....	7
8. SEAL SPRING CONTRACTION AND THRUST .....	7
9. COMBINATION WITH VALVE .....	8
10. AUTO-SETUP MODE.....	9
11. PROGRAMMING UNIT (MODEL: PU-2x).....	12
12. MODBUS COMMUNICATION .....	13
13. PARAMETER ITEMS COMMON TO MODBUS AND PU-2x .....	14
13.1. Note for parameter items .....	14
13.2. Device information.....	14
13.3. Diagnostics .....	14
13.4. Clear diagnostics.....	15
13.5. Modbus input .....	15
13.6. Modbus operation mode .....	15
13.7. Modbus setting .....	16
13.8. Basic setting .....	16
13.9. Setting/executing Auto-setup .....	16
14. COMBINATION OF OPERATION MODE AND SPECIFICATIONS .....	17
15. MAINTENANCE.....	18
16. TROUBLESHOOTING .....	18
17. LIGHTNING SURGE PROTECTION .....	18

# 1. BEFORE USE ....

Thank you for choosing us. Before use, please check contents of the package you received as outlined below. If you have any problems or questions with the product, please contact our sales office or representatives.

## ■ PACKAGE INCLUDES:

Mini-Top Electronic Actuator unit .....(1)

The Mini-Top Electronic Actuator is not provided with a yoke or other components required for mounting the unit to a valve. They are to be provided by the user.

## ■ MODEL NO.

Confirm Model No. marking on the product to be exactly what you ordered.

## ■ SAFETY PRECAUTIONS

Before use, please read all the following precautions carefully to ensure the safety. These safety precautions, classified into "WARNING" and "CAUTION" according to the degree of damage that may be caused by improper use of the product, are imperative to prevent an accident. After reading, be sure to keep this manual always in a visible and accessible place for the user.

△ WARNING Suggesting that failure to observe the precautions could result in death or serious personal injury.

△ CAUTION Suggesting that failure to observe the precautions could result in personal injury or damage to the property.

### △ WARNING

Remove power supply to the actuator before wiring to the unit. It could cause electric shock.

Do not disassemble or modify the unit in any way. It could cause electric shock, burn, or injury.

DO NOT step onto the actuator unit.  
DO NOT rest a heavy object on or against the unit.  
It could cause personal injury.

When installing the actuator unit outdoor or where it is exposed to rain or water drops, adequate precautions must be taken for preventing water from entering inside through wiring conduits. It could cause electric shock.

### △ CAUTION

DO NOT remove the cover of the actuator. It may cause electric shock or injury.

The adjusters which are paint-sealed are for factory use only and should be changed only by qualified our personnel. Otherwise it could cause breakdown.

We are not liable for any malfunction or inconvenience caused by unauthorized changes made by the user.

## ■ INSTRUCTION MANUAL

This manual describes necessary points of caution for handling this product and specifically for installation, wiring, hardware setting, and basic maintenance of the product.

This unit is factory-adjusted and calibrated according to the Ordering Information Sheet.

When the user needs to change settings, please also refer to the Section B of Operation Manual (EM-9255) for the Programming Unit (Model: PU-2x).

## 2. POINTS OF CAUTION

### ■ POWER INPUT RATING & OPERATIONAL RANGE

- Locate the power input rating marked on the product and confirm its operational range as indicated below:  
24V DC: 24V rating  $\pm 10\%$ , approx. 0.6A

### ■ HUNTING

- Hunting is a condition in which the output stem is oscillated repeatedly and persistently without settling at a single position.
- The actuator unit must operate at an average duty cycle of 50% (approx. 13 strokes per minute) or less.

### ■ GENERAL PRECAUTIONS

- Remove the power supply to the actuator before wiring the unit.
- DO NOT install signal wires and power supply wires together in one duct because it may cause a malfunction due to induction noises. Alternatively, use shielded cables for the input signal wires to prevent interference from such noises.
- If input signals are to be turned on/off with power supplied to the actuator, be sure to specify the output stem operation for when abnormally low input is detected.
- DO NOT loosen the screws fixing the potentiometer inside the unit.

### ■ INSTALLATION

- Indoor, or outdoor where the unit is NOT exposed to direct sunlight.
- Operating temperature  $-5$  to  $+55^{\circ}\text{C}$  ( $23$  to  $+131^{\circ}\text{F}$ )
- Operating humidity 30 to 85% RH (non-condensing)
- The unit is not designed to withstand all vibrations. We do not guarantee long-term use of the unit even with small vibrations. Please use the unit only after evaluating in an actual installation environment. Particularly, avoid using under the condition where valve cavitation or water hammer is likely to occur.
- Install the unit where it can be reached for maintenance and inspection. Be sure to allow at least 20 cm (7.9 inches) clearance above the unit and around the terminal box.
- Keep away from hazardous atmosphere such as explosive or corrosive gases.

### ■ PID CONTROL SIGNAL

- Choose PID parameters carefully so that the MV remains as stable as possible to prevent hunting. Unstable control shortens the life of actuator and valve.

### ■ REATTACHING TERMINAL BOX COVER

- When reattaching the terminal box cover after wiring, make sure that the O-rings are securely in place.

### ■ SCREW TORQUE

- The torque for tightening screws for the terminal cover is between  $1.2 - 2 \text{ N}\cdot\text{m}$  ( $0.89 - 1.5 \text{ ft}\cdot\text{lb}$ ). The screws must be tightened evenly and crosswise in several steps to prevent uneven clamping.

### ■ YOKE DESIGN

- When a foreign object is caught in the valve, an excessive torque may be applied to the yoke. Taking it into account, design the yoke and joint so as to have sufficient margin in strength.
- When this unit is used in an application such as temperature control of a steam line, the temperature can rise higher than the ambient temperature due to heat conducted through or radiated from the piping. Use a longer yoke for effective heat dissipation and apply insulation material.

### 3. COMPONENT IDENTIFICATION

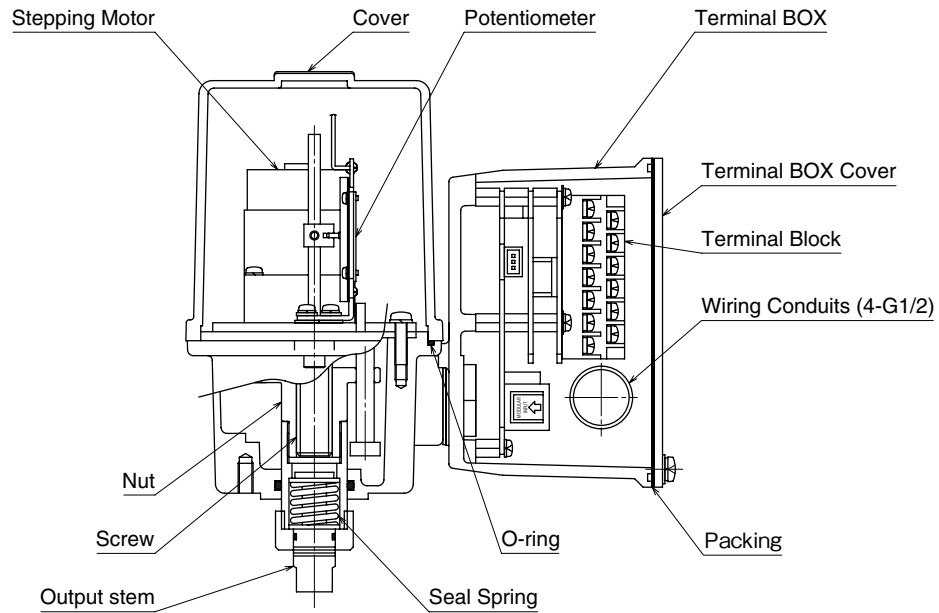

Figure 1. Component identification: MSP40/MSP50

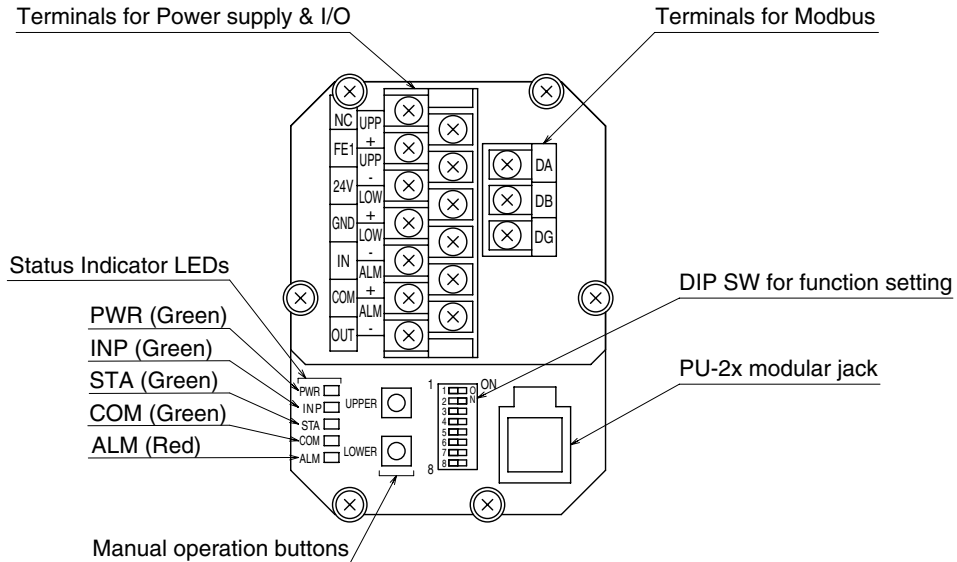

Figure 2. Component identification: Terminal Box

## 4. STATUS INDICATOR LED AND SIDE DIP SWITCH

### ■ STATUS INDICATOR LED

ID	COLOR	STATUS	FUNCTION
PWR	Green	ON	Power is ON.
INP	Green	ON	Position setpoint input (analog) of 0.37 V or greater is applied. (With 250 Ω receiving resistor for current input)
STA	Green	Blinks at 1 Hz	Auto-setup is in process.
		Blinks at 5 Hz for 3 sec.	Auto-setup has been successfully completed.
COM	Green	ON for 1 sec.	Returning response.
ALM	Red	Blinks at 0.5 Hz	System error (memory)
		ON	Motor deadlock alarm is output.
		Blinks at 5 Hz	Auto-setup has failed.

### ■ SIDE DIP SWITCH SETTING

SW1	FUNCTION		
SW1-1 SW1-2	Specify the operation of the output stem when abnormally low input is detected. (INP LED is OFF).		
	SW1-1	SW1-2	Operation of the Output Stem
	–	ON	Stop
	OFF	OFF	Extend (Go DOWN)
	ON	OFF	Retract (Go UP)
SW1-3	OFF	Reverse (Output stem goes UP with 20 mA DC input)	
	ON	Direct (Output stem goes DOWN with 20 mA DC input)	
SW1-4	OFF	Output stem moves while the manual operation button is pressed in Manual Operation mode.	
	ON	Output stem moves inch by inch each time the manual operation button is pressed in Manual Operation mode for fine adjustment.	
SW1-5	The output stem position when the switch is turned OFF is recorded as the upper-end position.		
SW1-6	The output stem position when the switch is turned OFF is recorded as the lower-end position.		
SW1-7	Auto-setup starts when the switch is turned OFF in Manual Operation mode.		
SW1-8	OFF	Automatic operation (Operation is performed based on input signal or Modbus)	
	ON	Manual operation (Manual operation buttons are enabled and Auto-setup can be started.)	

### ■ MANUAL OPERATION BUTTON

ID	FUNCTION
UPPER	The output stem moves upward in Manual Operation mode as the button is pressed.
LOWER	The output stem moves downward in Manual Operation mode as the button is pressed.

### ■ PU-2X MODULAR JACK

Parameter settings for Auto-setup and communication settings for Modbus can be configured on PU-2x. In addition, operation status of the unit can be monitored on PU-2x.

## 5. WIRING CONNECTION

Remove the terminal box cover and wire to the terminal block according to the below figure.

The unit can be operated once the power voltage and input signal are connected.

Also wire retract/UP, extend/DOWN, alarm, and/or output signals, as necessary.

Modbus communication allows operation without analog input and monitoring of the operation status of the unit.

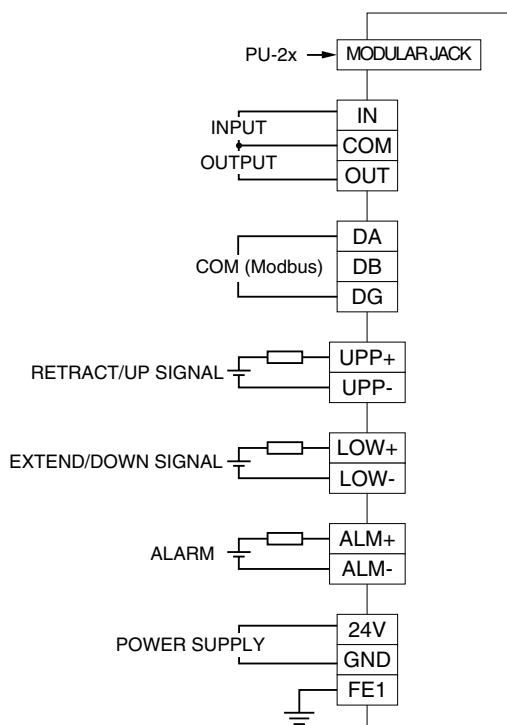

## 6. COMMUNICATION CABLE CONNECTIONS

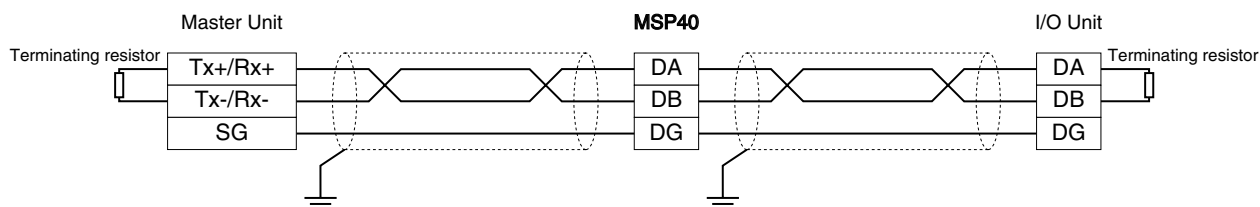

Terminating resistors can be turned ON/OFF on the programming unit (model: PU-2x).

## 7. OUTPUT STEM STROKES

Refer to the figure and the table below for the stroke range of the output stem according to the model. The upper-end position and the lower-end position can be set arbitrarily within the maximum stroke.

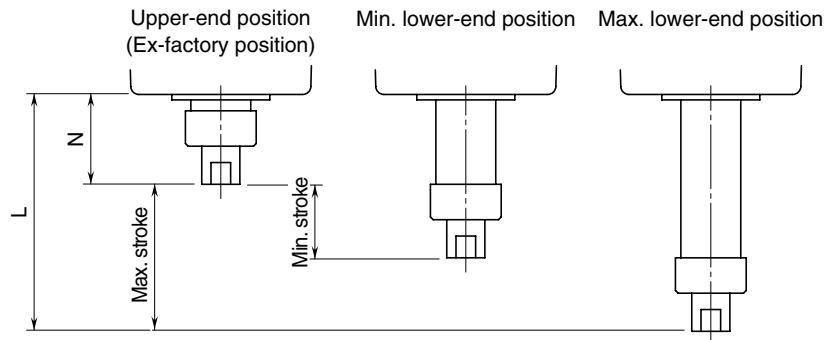

### • Minimum and Maximum strokes according to model

MODEL	N	L	MIN. STROKE	MAX. STROKE
MSP40-1	19	29	5	10
MSP40-2		34	8	15
MSP50-1	30	40	5	10
MSP50-2		50	10	20

## 8. SEAL SPRING CONTRACTION AND THRUST

### • Thrust and Seal Spring Contraction

MODEL	RATED THRUST (N)	THRUST WHEN VALVE IS SEATED (N)	THRUST WHEN AUTO-SEUP IS COMPLETE (N)	AJUSTABLE MAX. CONTRACTION: MAX. THRUST (N)	MAX. THRUST WHEN OUTPUT STEM IS LOCKED	MAX. COTRACTION (2 mm max.)
MSP40-x3	150	95	120	0.4 mm : 170N	340N min.	0.4 mm.
MSP40-x4	300	150	180	0.8 mm : 310N	800N min.	0.8 mm.
MSP40-x7	700	190	340	1.65 mm : 710N	1200N min.	1.65 mm.
MSP50-x3	150	100	120	0.4 mm : 170N	300N min.	0.4 mm.
MSP50-x4	300	160	190	0.8 mm : 310N	720N min.	0.8 mm.
MSP50-x7	700	190	270	1.65 mm : 720N	1200N min.	1.65 mm.

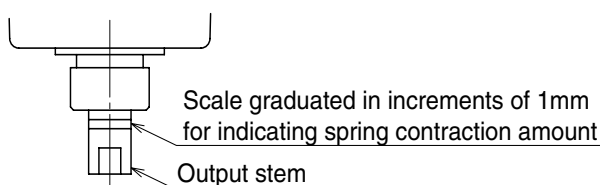

## 9. COMBINATION WITH VALVE

### ■ OPERATION DISTANCE WHEN COMBINED WITH VALVE

When setting the upper-stop position and the lower-stop position, it is preferable that the operation distance becomes 80% or less with respect to the maximum stroke of the actuator.

That is, when the valve is closed at the lower-end side of the actuator, if the maximum stroke is 20 mm and the lower-stop position is set at the 20.0 mm position, there will be no margin for the actuator to further go down to close the valve when valve leakage occurs. In such a case, Auto-setup may not be successfully completed.

In order to avoid such a situation, select an appropriate combination of an actuator and a valve to secure an enough operation distance. In the example below, the maximum stroke is 20 mm and thus the preferable operation distance is 16.0 mm. Set so that the distance between the upper-stop position and the lower-stop position are within the operation distance of 16.0 mm.

### ■ EXAMPLE OF PROPER OPERATION DISTANCE

When connecting the output stem of the actuator with the valve stem, determine their mounting position so that a proper operation distance can be secured.

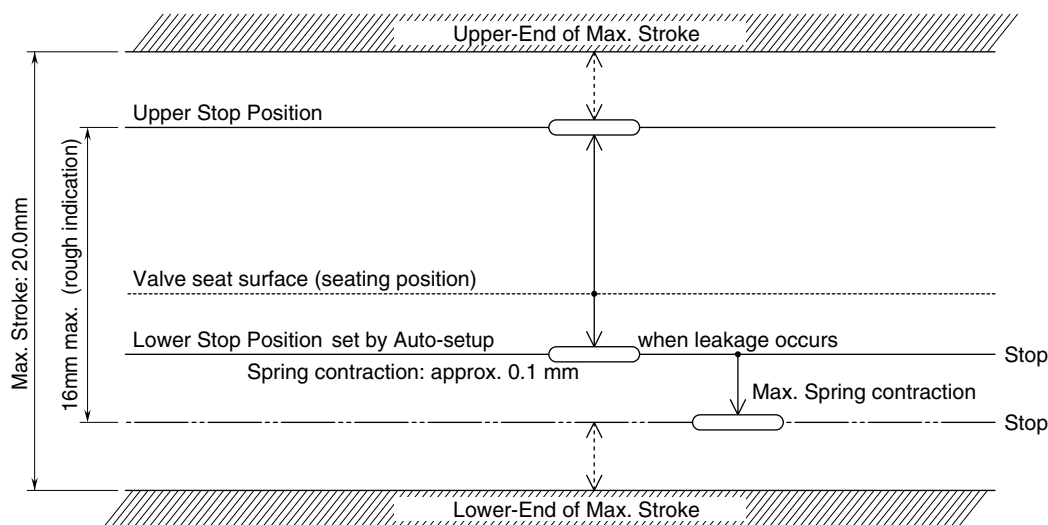

#### • Example of MSP Mounted to Valve

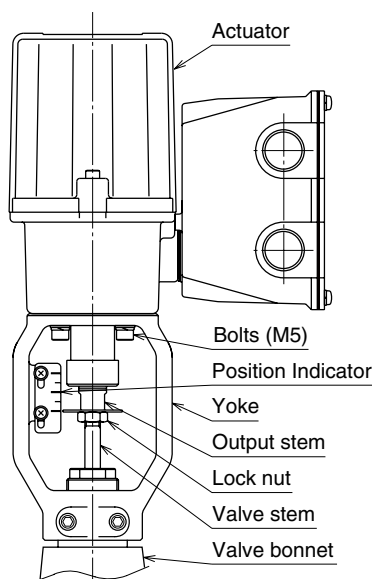



## 10. AUTO-SETUP MODE

Auto-setup is the function for automatically detecting the valve seat surface on the lower-end side and/or the upper-end side and determining the lower-stop position and the upper-stop position of the actuator.

Alternatively, by specifying the stroke length, the upper-stop or lower-stop position can be set to, for example, 13.00 mm upward/downward from the seated position.

The contraction of the seal spring in length on the lower-end side or the upper-end side is configured within the range of 0.1 mm to 1.2 mm in 0.1 mm increments.

Note that the ex-factory settings (e.g. Auto-setup type=0; Seal spring contraction= 0.1 mm; if not specified when ordering) can be changed on PU-2x or via Modbus.

Refer to 13.9 Setting/executing Auto-setup on page 17 for parameter items to configure.

### ■ HOW TO EXECUTE AUTO-SETUP

- 1) Turn ON SW1-8 to switch from Automatic Operation mode to Manual Operation mode.
- 2) Manipulate Manual operation buttons to move the actuator to an intermediate position.  
Specifically, press [LOWER] or [UPPER] button to move the output stem about 2 mm (allowable if 1 to 4 mm) downward or upward toward the middle position from the upper-end or the lower-end.  
Note that the stem moves differently depending on whether SW1-4 is ON or OFF (factory-set to OFF).  
Refer to the table in the section "FINE ADJUSTMENT AFTER AUTO-SETUP" for details.
- 3) Turn ON and OFF SW1-7 to start Auto-setup.  
Alternatively, started Auto-setup by entering a command on PU-2x (ITEM=54, DATA=1, Enter) or via Modbus.
- 4) Auto-setup is performed.  
STA LED blinks at 1 Hz while Auto-setup is in process.  
Specific steps according to the Auto-setup type are as described in the table below.
- 5) Confirm that Auto-setup has been successfully completed (SAT LED blinks at 5 Hz for 3 seconds).  
Turn OFF SW1-8 to end Auto-setup mode and switch back to Automatic Operation mode.  
Note that the actuator immediately starts to operate in accordance with a value of input signal.  
DO NOT touch the output stem and its vicinity, as it may cause serious injury to your hand or finger.
- 6) When Auto-setup has failed (ALM LED blinks at 5 Hz), clear error by any of the following methods, then revise the settings.
  - Turn ON and OFF SW1-7
  - Enter a clear error command on PU-2x (ITEM=54, DATA=2, Enter) or via Modbus.
  - Turn OFF and ON the power supply to the actuator unit.

### ■ PROCESS STEPS OF AUTO-SETUP ACCORDING TO AUTO-SETUP TYPE

- The Auto-setup type can be selected on PU-2x or via Modbus communication.

AUTO-SETUP TYPE	STEPS OF AUTO-SETUP
0: Lower seal spring	<ol style="list-style-type: none"> <li>1) The output stem goes down until the valve contacts the seat surface. (Auto-setup is interrupted if the valve reaches the lower-end before it contacts the seat surface.)</li> <li>2) The stem goes up until the valve contacts the seat surface or reaches the upper-end.</li> <li>3) The stem goes down to the position reached in step 1).</li> <li>4) The stem further compresses the seal spring downward from the seated position by the set amount. If no error occurs, the positions reached in step 2) and step 4) are saved as the upper-stop position and the lower-stop position, respectively.</li> <li>5) The stem moves to the 50% position between the upper-stop and lower-stop positions, then stops to end Auto-setup.</li> </ol>
1: Lower seal spring + Stroke specified	<ol style="list-style-type: none"> <li>1) The output stem goes down until the valve contacts the seat surface. (Auto-setup is interrupted if the valve reaches the lower-end before it contacts the seat surface.)</li> <li>2) The stem goes up toward the upper-end side by the specified stroke length. (Auto-setup is interrupted if the valve contacts the seat surface before reaching the specified stroke length.)</li> <li>3) The stem goes down to the position reached in step 1).</li> <li>4) The stem further compresses the seal spring downward from the seated position by the set amount. If no error occurs, the positions reached in step 2) and step 4) are saved as the upper-stop position and the lower-stop position, respectively.</li> <li>5) The stem moves to the 50% position between the upper-stop and lower-stop positions, then stops to end Auto-setup.</li> </ol>

AUTO-SETUP TYPE	STEPS OF AUTO-SETUP
2: Upper seal spring  (MSP50 only)	1) The output stem goes up until the valve contacts the seat surface. (Auto-setup is interrupted if the valve reaches the upper-end before it contacts the seat surface.) 2) The stem goes down until the valve contacts the seat surface or reaches the lower-end. 3) The stem goes up to the position reached in step 1). 4) The stem further compresses the seal spring upward from the seated position by the set amount. If no error occurs, the positions reached in step 2) and step 4) are saved as the lower-stop position and the upper-stop position, respectively. 5) The stem moves to the 50% position between the lower-stop and upper-stop positions, then stops to end Auto-setup.
3: Upper seal spring + Stroke specified  (MSP50 only)	1) The output stem goes up until the valve contacts the seat surface. (Auto-setup is interrupted if the valve reaches the upper-end before it contacts the seat surface.) 2) The stem goes down toward the lower-end side by the specified stroke length. (Auto-setup is interrupted if the valve contacts the seat surface before reaching the specified stroke length.) 3) The stem goes up to the position reached in step 1). 4) The stem further compresses the seal spring upward from the seated position by the set amount. If no error occurs, the positions reached in step 2) and step 4) are saved as the lower-stop position and the upper-stop position, respectively. 5) The stem moves to the 50% position between the lower-stop and upper-stop positions, then stops to end Auto-setup.
4: Lower & Upper seal springs  (MSP50 only)	1) The output stem goes down until the valve contacts the seat surface. (Auto-setup is interrupted if the valve reaches the lower-end before it contacts the seat surface.) 2) The output stem goes up until the valve contacts the seat surface. (Auto-setup is interrupted if the valve reaches the upper-end before it contacts the seat surface.) 3) The stem further compresses the seal spring upward from the seated position by the set amount. 4) The stem goes up to the position reached in step 1). 5) The stem further compresses the seal spring downward from the seated position by the set amount. If no error occurs, the positions reached in step 3) and step 5) are saved as the upper-stop position and the lower-stop position, respectively. 6) The stem moves to the 50% position between the upper-stop and lower-stop positions, then stops to end Auto-setup.

#### ■ FINE ADJUSTMENT AFTER AUTO-SETUP

The stop position determined by Auto-setup can be fine-adjusted further toward the lower-end or upper-end side considering valve leakage using Manual operation buttons.

- 1) Turn SW1-8 from OFF to ON to switch to Manual operation mode.  
 Manual operation buttons are enabled to fine-adjust the position of the output stem.  
 (If SW1-8 is kept OFF, control by input signal or Modbus takes priority over Manual operation.)
- 2) Turn SW1-4 ON or OFF depending on which method to adopt.  
 Movement of the output stem by Manual operation buttons differs as shown in the table below.

Note) In Manual Operation mode, an alarm will not be triggered when the output stem is locked.

Thus, perform button operation carefully while watching the scale markings (1-mm intervals), and DO NOT move the output stem to an extent that compresses the seal spring by more than 1 mm.

Basically, it is safe to move the output to the upper/lower end.

SW1-4 : OFF	SW1-4 : ON	
<p>To fine-adjust the position of the output stem: Press [UPPER] or [LOWER] button to move the output stem upward or downward. The output stem keeps moving while the button is pressed and stops as the button is released.</p>	Press [UPPER] or [LOWER] button once to move the output stem upward or downward by the specified distance.	
	Moving Distance (approx.)	Setting
	0.05 mm	Standard EX-factory setting
	0.02 mm	Selected on PU-2x
	0.1 m	Selected on PU-2x
	For example, when the moving distance is set to 0.05 mm, pressing the button 10 times moves the output stem by approx. 0.5 mm.	
<p>To complete the fine adjustment: &lt;Lower-end side&gt; Turn SW1-5 from OFF to ON, then to OFF again to newly set the lower-end position. &lt;Upper-end side&gt; Turn SW1-6 from OFF to ON, then to OFF again to newly set the upper-end position.</p>	<p>To complete the fine adjustment: &lt;Lower-end side&gt; Turn SW1-5 from OFF to ON, then to OFF again to newly set the lower-end position. &lt;Upper-end side&gt; Turn SW1-6 from OFF to ON, then to OFF again to newly set the upper-end position.</p>	

Note) In Manual Operation mode, an alarm will not be triggered even if the output stem is locked. Thus, perform button operation carefully while watching the scale markings at 1-mm intervals, and DO NOT move the output stem to an extent that will compress the seal spring by more than 1 mm. Basically, it is safe to move the output stem by the factory-set amount (spring contraction amount can be specified when ordering; 0.1 mm if not specified).

#### ■ DEADBAND SETTING

Deadband can be configured on PU-2x or via Modbus communication.  
Refer to “13.8. Basic setting” for details.  
Standard EX-factory setting: 0.3% \*

#### ■ RESTART LIMITING TIMER

Restart limiting timer can be configured on PU-2x or via Modbus communication.  
Refer to “13.8. Basic setting” for details.  
Standard EX-factory setting: 1.5 sec. \*

\* The standard EX-factory setting will be applied unless otherwise specified when ordering.

## 11. PROGRAMMING UNIT (MODEL: PU-2x)

The Programming Unit (model: PU-2x) helps the user to configure various parameters, execute Auto-setup, and to monitor operation status of the actuator.

Turn SW1-8 ON to enable configuration and Auto-setup execution on PU-2x.

Monitoring can be conducted regardless of whether SW1-8 is ON or OFF.

### ■ DISPLAY OF PU-2x

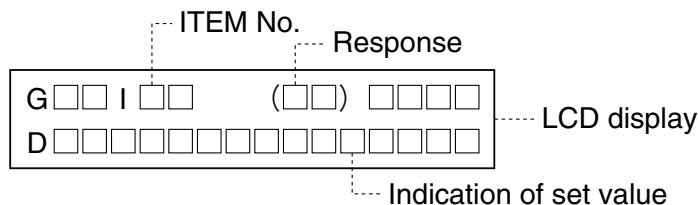

### ■ HOW TO USE PU-2x

- 1) Turn SW1-8 ON to enable configuration or Auto-setup execution.
- 2) Connect the connection cable of PU-2x to the modular jack on the actuator unit.  
The display of PU-2x comes on by power supplied to the actuator unit.
- 3) To display a target item, press [ITEM], then [N], [N] ([N] represents numerical number 0 to 9).  
Alternatively, use [UP] or [DOWN] button to shift to the next item from the currently displayed item.
- 4) To change the setting value of the target item being displayed, press [DATA], enter a value, and press [ENTER].  
Enter an integer or a value with one decimal place depending on the item.  
When setting a tag, alphabetic characters can be used.
- 5) Confirm that 'OK' is displayed.  
If the entered value is invalid or SW1-8 is OFF, 'DATA-ERR' will be displayed.
- 6) When configuration or Auto-setup is completed, remove the connect cable of PU-2x from the actuator unit, and turn SW1-8 OFF.

### ■ RESPONSE MESSAGES

OK : OK  
 NON-ITEM : Item is not applicable  
 DATA-ERR : Value is invalid or out of range

### ■ PARAMETER ITEM LIST

Refer to "13. PARAMETER ITEMS COMMON TO MODBUS AND PU-2x" for the parameter item list.

## 12. MODBUS COMMUNICATION

Modbus communication allows execution of Auto-setup and monitoring of the operation status of the actuator in the same manner as the programming unit (model: PU-2x).

Position setpoint can be input via Modbus instead of analog signal.

### ■ MODBUS COMMUNICATION SPECIFICATION

This unit supports Modbus-RTU protocol.

ITEM	SETTING RANGE	EX-FACTORY SETTING
Node address	1 to 247 (Configurable on PU-2x)	1
Baud rate	800 / 9600 / 19200 / 38400 bps (Configurable on PU-2x)	38400 bps
Parity	Odd	Odd
Stop bit	1	1

### ■ MODBUS COMMANDS

FUNCTION	COMMAND	DESCRIPTION
03	Read Holding Registers	Reads the value(s) of a single or multiple holding registers.
04	Read Input Registers	Reads the value(s) of a single or multiple input registers.
06	Preset Single Register	Presets a value in a single holding register.
16	Preset Multiple Registers	Presets values in respective multiple holding registers.

It is recommended to set timeout for response to 0.5 sec. or longer.

'0' is returned when an address to which no register is assigned is read.

An exception response is returned when attempting to write to an address which is not writable.

Even if the address is writable, make sure to set [Modbus Operation mode (address 111)] in advance to enable writing.

### ■ ADDRESS MAP

Refer to "13. PARAMETER ITEMS COMMON TO MODBUS AND PU-2x" for Modbus address map.

### ■ DATA VALUE

When [Value Range] of the data is specified as numbers with one digit after the decimal point, the data is multiplied by 10 and handled as an integer. That is, '25.8' is handled as '258', for example.

When the Data type is 'I16', data is an integer between -32768 to 32767, and when the Data type is 'I32', data is a long 32-bit integer between -2147483648 to 214783647.

Long data is in little endian format.

### ■ POSITION SETPOINT INPUT VIA MODBUS

The position setpoint can be input via Modbus communication by the following procedure.

- 1) Set [Input mode (Modbus=address 124, PU-2x= ITEM 63)] as 'Modbus input'.
- 2) Write a position setpoint value (e.g. '700' for 70.0 %) to Address 101.
- 3) Write '1' to Address 111 to enable Modbus input, thereby moving the output stem toward the setpoint.

Note)

- When a motor deadlock error occurs, '1' or '2' is set in Address 48.  
Write '1' to Address 57 to clear the error.
- When [Modbus disconnection detection time (Modbus=address 125, PU-2x= ITEM 64)] is set, a Modbus disconnection error is detected when a Modbus command is not issued for the set time period, thereby causing the output stem to stop, extend (move downward), or retract (move upward) according to the settings of DIP switches 1-1 and 1-2 of the unit.
- Refer also to "14. COMBINATION OF OPERATION MODE AND SPECIFICATIONS".

## 13. PARAMETER ITEMS COMMON TO MODBUS AND PU-2x

### 13.1. Note for parameter items

ITEM	DESCRIPTION
MODBUS TYPE	I16=Integer type data, I32=Long type data (little endian)
VALUE RANGE	Value with one decimal place is multiplied by 10 and handled as an integer. Value is used as is with one decimal place on PU-2x.
PU-2x DISPLAY	x represents a number.
R/W	R= Read only R/W=Read and Write
SAVE	Setting is saved for the item with '✓' in the [Save] column.

### 13.2. Device information

MODBUS		ITEM	VALUE RANGE	INITIAL VALUE	PU-2x		R/W	SAVE
ADDRESS	TYPE				ITEM	DISPLAY		
1	I16	Msp format 'MSPxx - yz' is expressed by 4-digits of xxyz	4013 to 5037	–	01	Model:x	R	–
2	I16	Firmware: Major version	0 to 9	–	02	Ver:x.y.z	R	–
3	I16	Firmware: Minor version	0 to 99					
4	I16	Firmware: Revision	0 to 99					
5 to 16	I16 x 12	Tag setting · ASCII code (0x20 to 07x7E) · Stored in order from the head address · On PU-2x, enter characters as needed and the rest, if any, is entered as space.	ASCII code (0x20 to 0x7E) x 12 characters	blank (0x20)	03	Tg.xxxx...xx	R/W	✓
17	I16	Analog input (%)	-25.0 to 125.0	–	04	Inp:x	R	–
18	I16	Position setpoint (%) *1	-5.0 to 105.0	–	05	Tar:x	R	–
19	I16	Position (%) *1	-5.0 to 105.0	–	06	Pos:x	R	–

\*1 The ratio to the operation distance (i.e. a distance between the lower-stop position and the upper-stop position).

### 13.3. Diagnostics

MODBUS		ITEM	VALUE RANGE	INITIAL VALUE	PU-2x		R/W	SAVE
ADDRESS	TYPE				ITEM	DISPLAY		
21	I32	Total power-on time (hour)	0 to 596523	0	07	PowTm:x	R	–
23	I32	Total operation time (hour)	0 to 596523	0	08	MovTm:x	R	–
25	I32	Total operation distance (1 count per operation distance *2)	0 to 99999999	0	09	Dist:x	R	–
27	I32	No. of times of motor start actions	0 to 99999999	0	10	Strt:x	R	–
29	I32	No. of times of motor reverse actions	0 to 99999999	0	11	Rvrs:x	R	–
31	I32	No. of times of motor restart	0 to 99999999	0	12	Rtry:x	R	–
33	I32	No. of times when the duty cycle per minute exceeded 50%	0 to 99999999	0	13	Over:x	R	–
35	I16	Duty cycle (%) per minute	0.0 to 100.0	0.0	14	Duty:	R	–
36	I16	Time ratio (%) of - 10% position *3	0.0 to 100.0	0.0	15	Pos0R:x	R	–
37	I16	Time ratio (%) of 10 - 20% position *3	0.0 to 100.0	0.0	16	Pos10R:x	R	–
38	I16	Time ratio (%) of 20 - 30% position *3	0.0 to 100.0	0.0	17	Pos20R:x	R	–
39	I16	Time ratio (%) of 30 - 40% position *3	0.0 to 100.0	0.0	18	Pos30R:x	R	–
40	I16	Time ratio (%) of 40 - 50% position *3	0.0 to 100.0	0.0	19	Pos40R:x	R	–
41	I16	Time ratio (%) of 50 - 60% position *3	0.0 to 100.0	0.0	20	Pos50R:x	R	–
42	I16	Time ratio (%) of 60 - 70% position *3	0.0 to 100.0	0.0	21	Pos60R:x	R	–

MODBUS		ITEM	VALUE RANGE	INITIAL VALUE	PU-2x		R/W	SAVE
ADDRESS	TYPE				ITEM	DISPLAY		
43	I16	Time ratio (%) of 70 - 80% position *3	0.0 to 100.0	0.0	22	Pos70R:x	R	-
44	I16	Time ratio (%) of 80 - 90% position *3	0.0 to 100.0	0.0	23	Pos80R:x	R	-
45	I16	Time ratio (%) of 90% - position *3	0.0 to 100.0	0.0	24	Pos90R:x	R	-
46	I16	Motor deadlock error 0: Normal 1: Locked when moving upward 2: Locked when moving downward	0 to 2	-	25	Lock:x	R	-

\*2 The operation distance is a distance between the lower-stop position and the upper-stop position.

\*3 The time ratio in percentage to the total operation time.

## 13.4. Clear diagnostics

MODBUS		ITEM	VALUE RANGE	INITIAL VALUE	PU-2x		R/W	SAVE
ADDRESS	TYPE				ITEM	DISPLAY		
51	I16	Clear total values of the items below. · Total power-on time (hour) · Total operation time (hour) · Total operation distance · No. of times of motor start actions · No. of times of motor reverse actions · No. of times of motor restart · No. of times when the duty cycle per minute exceeded 50% 1: Clear	0, 1	0	26	AccumClr:x	R/W	-
52	I16	Time ratio (%) of respective % positions 1: Clear	0, 1	0	27	PosRClr:x	R/W	-
53	I16	Clear all diagnostics 1: Clear	0, 1	0	28	DiagAllClr:x	R/W	-
54	I16	Clear motor deadlock alarm 1: Clear	0, 1	0	29	LockRelease:x	R/W	-

## 13.5. Modbus input

MODBUS		ITEM	VALUE RANGE	INITIAL VALUE	PU-2x		R/W	SAVE
ADDRESS	TYPE				ITEM	DISPLAY		
101	I16	Modbus position setpoint input (%)	-5.0 to 105.0	0	-	-	R/W	-

## 13.6. Modbus operation mode

MODBUS		ITEM	VALUE RANGE	INITIAL VALUE	PU-2x		R/W	SAVE
ADDRESS	TYPE				ITEM	DISPLAY		
111	I16	Modbus operation mode (Forcibly returned to '0' when SW1-8=ON) 0: Monitor mode 1: Modbus input mode 2: Configuration mode	0 to 2	0	-	-	R/W	-
		[0: Monitor mode] · R/W registers of addresses up to 111 are readable and writable. · Registers other than the above are read only.						
		[1: Modbus input mode] · R/W registers of addresses up to 111 are readable and writable. · Registers other than the above are read only. · When [Input mode= Modbus input], the actuator operates according to [Modbus position setpoint input].						
		[2: Configuration mode] · All R/W registers are readable and writable. · Registers other than the above are read only. · Operation stops (Actuator operates when a command for starting Auto-setup is entered via Modbus.)						

## 13.7. Modbus setting

MODBUS		ITEM	VALUE RANGE	STANDARD EX-FACTORY*4	PU-2x		R/W	SAVE
ADDRESS	TYPE				ITEM	DISPLAY		
121	I16	Node address	1 to 247	1	60	Addr:x	R/W	✓
122	I16	Baud rate 0: 4.8 kbps 1: 9.6 kbps 2: 19.2 kbps 3: 38.4 kbps	0 to 3	3	61	Baud:x	R/W	✓
123	I16	Internal terminating resistor 0: OFF 1: ON	0, 1	0	62	Term:x	R/W	✓
124	I16	Input mode 0: Analog input 1: Modbus input	0, 1	0	63	InputSel:x	R/W	✓
125	I16	Modbus disconnection detection time (When Modbus disconnection is detected during Modbus input mode, the actuator operates according to SW1-1 and 1-2 settings of the unit.) 0: No detection 1: Detects disconnection when a Modbus command is not issued for the set time period	0 to 300	0	64	Timeout:x	R/W	✓

\*4 The standard EX-factory setting will be applied unless otherwise specified when ordering.

## 13.8. Basic setting

MODBUS		ITEM	VALUE RANGE	STANDARD EX-FACTORY*4	PU-2x		R/W	SAVE
ADDRESS	TYPE				ITEM	DISPLAY		
131	I16	Upper-stop position %	8.0 to 100.0	100.0	40	OpnPos:x	R/W	✓
132	I16	Lower-stop position %	0.0 to 92.0	0.0	41	ClsPos:x	R/W	✓
133	I16	Upper-end limit %	75.0 to 105.0	100.0	42	OpnLim:x	R/W	✓
134	I16	Lower-end limit %	-5.0 to 25.0	0.0	43	ClsLim:x	R/W	✓
135	I16	Retract/UP signal position %	75.0 to 105.0	98.0	44	OpnSig:x	R/W	✓
136	I16	Extend/DOWN signal position %	-5.0 to 25.0	2.0	45	ClsSig:x	R/W	✓
137	I16	Deadband %	0.1 to 5.0	0.3	46	DBand:x	R/W	✓
138	I16	Restart limiting timer (sec.)	0.0 to 30.0	1.5	47	Restart:x	R/W	✓
139	I16	Moving distance of the output stem for fine adjustment in Manual Operation mode 0: 0.02 mm 1: 0.05 mm 2: 0.1 mm	0 to 2	1	48	Manual:x	R/W	✓

\*4 The standard EX-factory setting will be applied unless otherwise specified when ordering.

## 13.9. Setting/executing Auto-setup

MODBUS		ITEM	VALUE RANGE	STANDARD EX-FACTORY*4	PU-2x		R/W	SAVE
ADDRESS	TYPE				ITEM	DISPLAY		
141	I16	Auto-setup type 0: Lower seal spring 1: Lower seal spring & Stroke specified 2: Upper seal spring 3: Upper seal spring & Stroke specified 4: Lower & Upper seal springs (2 to 4 are available only for MSP50)	MSP40: 0, 1 MSP50: 0 to 4	0	50	ASType:x	R/W	✓
142	I16	Lower seal spring contraction amount (mm)	0.1 to 1.2	0.1	51	ASPushDn:x	R/W	✓
143	I16	Upper seal spring contraction amount (mm)	0.1 to 1.2	0.1	52	ASPushUp:x	R/W	✓
144	I16	Stroke / operation distance (mm)	3.0 to 20.0	5.0	53	ASStroke:x	R/W	✓
145	I16	Execute Auto-seup 1: Start 2: Abort / Clear error	0 to 2	0	54	ASStart:x	R/W	–
146	I16	Auto-setup history 1: Upper-stop position %	8.0 to 100.0	0.0	55	AS1Opn:x	R	–
147	I16	Auto-setup history 2: Lower-stop position %	0.0 to 92.0	0.0	56	AS1Cls:x	R	–
148	I16	Auto-setup history 3: Upper-stop position %	8.0 to 100.0	0.0	57	AS2Opn:x	R	–
149	I16	Auto-setup history 4: Lower-stop position %	0.0 to 92.0	0.0	58	AS2Cls:x	R	–

\*4 The standard EX-factory setting will be applied unless otherwise specified when ordering.



## 14. COMBINATION OF OPERATION MODE AND SPECIFICATIONS

OPERATION MODE			OPERATION SPECIFICATIONS					
Manual operation	Input mode (*1)	Modbus operation mode (*3)	Output stem operation	SW1-7	PU-2x		Modbus	
				Retract (UP) / Extend (DOWN)	Read data / Clear data command (*7)	Setting change / Auto-setup	Read data / Clear data command (*8)	Setting change / Auto-setup
OFF	Analog input	Monitor mode	Follows analog input (*5)	–	✓	–	✓	–
		Modbus input mode	Stops	–	✓	–	✓	–
		Configuration mode	Stops	–	✓	–	✓	✓
	Modbus input	Monitor mode	Stops	–	✓	–	✓	–
		Modbus input mode	Follows Modbus input (Address 101)	–	✓	–	✓	–
		Configuration mode	Stops	–	✓	–	✓	✓
ON	N/A (*2)	Monitor mode (*4)	Moves by button operation	✓	✓	✓	✓	–

\*1 Configurable on PU-2x (ITEM 63) or via Modbus (Address 124).

\*2 No difference between 'Analog input and 'Modbus input'.

\*3 The mode is switched via Modbus (address 111).

\*4 Turn SW1-8 ON to forcibly switch the Modbus input mode to Monitor mode.

\*5 The output stem operates according to the settings of SW1-1 and 1-2 when abnormally low input is detected.

\*6 The output stem operates according to the settings of SW1-1 and 1-2 when a Modbus disconnection error is detected.

\*7 Clear diagnostics, motor deadlock error, TAG, etc.

\*8 Clear diagnostics, motor deadlock error, TAG, written Addresses 101, 111, etc.

## 15. MAINTENANCE

For effective use and longer life of the Mini-Top electronic actuator, regular checking appropriate for its operating conditions are recommended. Refer to the following table.

ITEM	CHECKING POINT	HOW TO PROCEED
Stem operation	Apply input 0%, 50%, 100%, then back to 50%, 0%. Check that the actuator operates to the correct positions at respective input values.	Repair or calibrate the unit.
Abnormal sound	No abnormal sound is heard during operation.	Repair or calibrate the unit.
Water or rust inside the housing	Check that there is no water or rust inside the housing. If there is water inside, check the packing and the wiring cable connector is not loose.	Remove water and dry the housing and the parts inside. Replace rusted parts, if any. Replace the packing, if damaged. Re-tighten cable connector, if loose.
Screws	Check that screws and bolts are securely fastened.	Re-tighten them, if loose.

For repair or parts replacement, contact us or our representatives.

### ■ LUBRICATION

There is no need of oiling the Mini-Top electronic actuator in normal operating conditions.

### ■ REGULAR TEST RUNNING

If the valve is not frequently operated, run a test operation regularly (once a week, for example) to ensure that the actuator operates normally.

## 16. TROUBLESHOOTING

TROUBLE	LED				POSSIBLE CAUSE	HOW TO PROCEED
	PWR	INP	COM	ALM		
Actuator does not work (Analog input)	OFF	–	–	–	Power failure Cable breakage	Check the power supply and cables.
	ON	OFF	–	–	Input error	Check the input signal level.
	ON	ON	–	–	Mode is set to Manual operation or Modbus input mode.	Check the operation mode.
	ON	ON	–	ON	Motor deadlock error	Apply input in reverse direction.
Actuator does not work (Modbus input)	ON	–	OFF		Modbus communication is not established.	Check the communication cable. Check the Node address. Check the baud rate.
	ON	–	Blinks		Mode is set to Manual operation or Analog input mode.	Check the operation mode.
	ON	–		ON	Motor deadlock error	Clear error via Modbus.
Unstable operation	–	–	–	–	Abnormal power voltage, Noise	Check power voltage and noise in input signal.

## 17. LIGHTNING SURGE PROTECTION

We offer a series of lightning surge protectors for protection against induced lightning surges. Please consult us to choose appropriate models.