

**SELF-SYNCH TRANSMITTER**  
(front configurable)

MODEL

**MXS**

**BEFORE USE ....**

Thank you for choosing us. Before use, please check contents of the package you received as outlined below. If you have any problems or questions with the product, please contact our sales office or representatives.

**■ PACKAGE INCLUDES:**

Signal conditioner (body + base socket).....(1)

**■ MODEL NO.**

Confirm Model No. marking on the product to be exactly what you ordered.

**■ INSTRUCTION MANUAL**

This manual describes necessary points of caution when you use this product, including installation, connection and basic maintenance procedures.

**POINTS OF CAUTION**

**■ POWER INPUT RATING & OPERATIONAL RANGE**

- Locate the power input rating marked on the product and confirm its operational range as indicated below:  
85 – 132V AC rating: 85 – 132V, 47 – 66 Hz, approx. 6VA  
170 – 264V AC rating: 170 – 264V, 47 – 66 Hz, approx. 6VA

**■ GENERAL PRECAUTIONS**

- Before you remove the unit from its base socket or mount it, turn off the power supply and input signal for safety.

**■ ENVIRONMENT**

- Indoor use.
- When heavy dust or metal particles are present in the air, install the unit inside proper housing with sufficient ventilation.
- Do not install the unit where it is subjected to continuous vibration. Do not subject the unit to physical impact.
- Environmental temperature must be within -5 to +55°C (23 to 131°F) with relative humidity within 30 to 90% RH in order to ensure adequate life span and operation.

**■ WIRING**

- Do not install cables close to noise sources (relay drive cable, high frequency line, etc.).
- Do not bind these cables together with those in which noises are present. Do not install them in the same duct.

**■ AND ....**

- The unit is designed to function as soon as power is supplied, however, a warm up for 10 minutes is required for satisfying complete performance described in the data sheet.

**COMPONENT IDENTIFICATION**

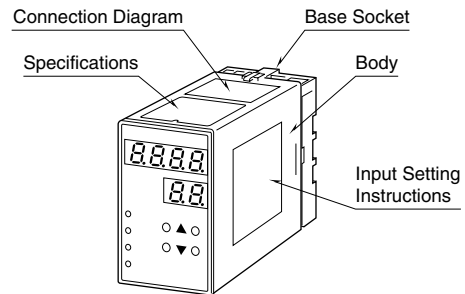

**INSTALLATION**

Detach the yellow clamps located at the top and bottom of the unit for separate the body from the base socket.

**■ DIN RAIL MOUNTING**

Set the base socket so that its DIN rail adaptor is at the bottom. Position the upper hook on the DIN rail and push in the lower. When removing the socket, push down the DIN rail adaptor utilizing a minus screwdriver and pull.

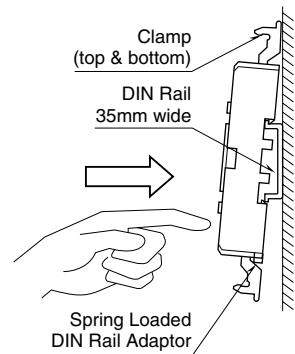

**■ WALL MOUNTING**

Refer to “EXTERNAL DIMENSIONS.”

Shape and size of the base socket are slightly different with various socket types.

## TERMINAL CONNECTIONS

Connect the unit as in the diagram below or refer to the connection diagram on the top of the unit.

### EXTERNAL DIMENSIONS unit: mm (inch)

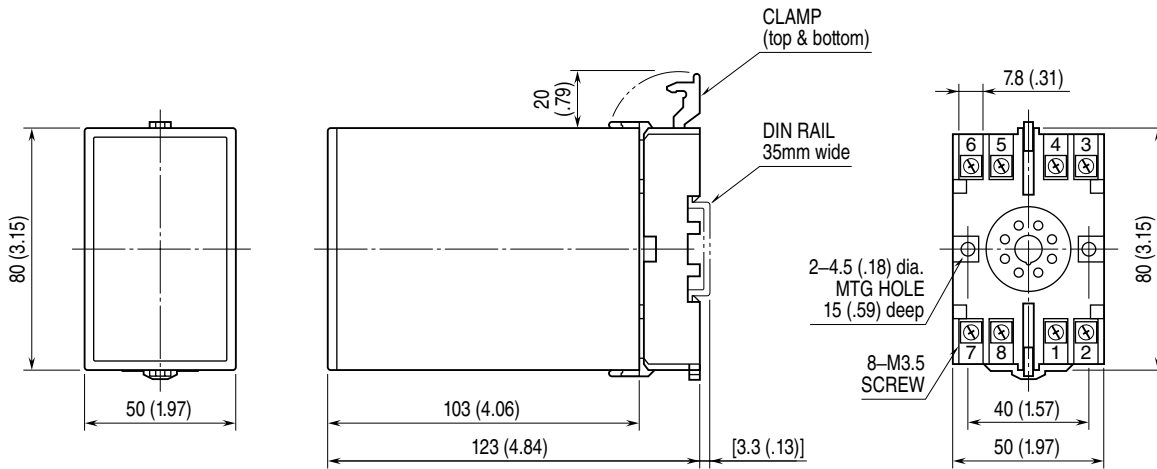

• When mounting, no extra space is needed between units.

### CONNECTION DIAGRAM

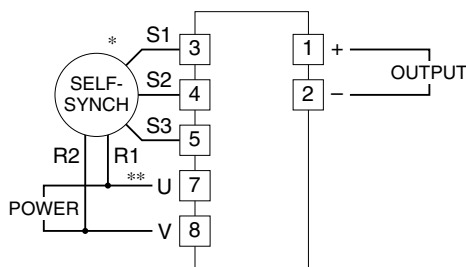

- \* The output increases when the self-synch rotates clockwise  
For changing the operation to counterclockwise, reverse the connection of S2 and S3.
- \*\*Be sure that the polarity of the power input to the signal conditioner matches to the self-synch input polarity. When the connection is reversed, the signal conditioner output will be shifted by 180°.

## FRONT PANEL CONFIGURATION & PROGRAMMING

### PROGRAMMING PROCEDURE

- 1) Press ITEM UP or DOWN key until ITEM display indicates "01".
- 2) Press DATA UP or DOWN key and choose "2" on DATA display.
  - 1: Data indication only.
  - 2: All parameters are modifiable.
- 3) Press ITEM UP or DOWN key until ITEM display shows the ITEM No. you need to change.
- 4) Press DATA UP or DOWN key and choose a DATA No. or value you need on DATA display.
- 5) Repeat above 3 and 4. (Entered data is stored 1 sec. after the operation has been complete.)
- 6) Press ITEM UP or DOWN key until ITEM display indicates "01".
- 7) Press DATA UP or DOWN key and choose "1" on the display.
- 8) Press ITEM UP or DOWN key until ITEM display indicates "P".  
DATA display shows process input. You can now check data setting by choosing ITEM No.

Note: DO NOT press UP and DOWN keys simultaneously.

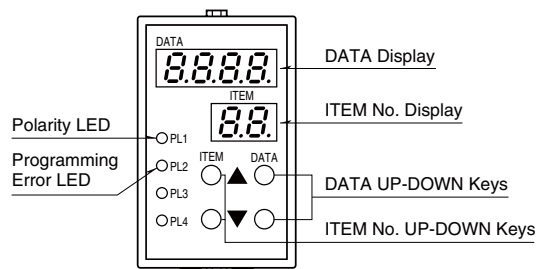

ITEM	MDF CODE	DATA	CONTENTS	DEFAULT
P	N/A	-180.0 – 360.0	Input display in angle	---
01		1, 2, 3	Modification code 1: Data indication only. 2: All parameters are modifiable. 3: Only ITEM 19 is modifiable.	1
02	N/A	0 – 99	Status indication ("0" is normally indicated.)	---
03	2	0, 1	0° (%) input setting by actual position input *1	0
04	2	0, 1	100% input setting by actual position input *1 (canceled by ITEM 06 setting)	0
05	2	-180.0 – 180.0	0° (%) input angle adjustment (fine adj. of the value set in ITEM 03) *2	0.0
06	2	0.0 – 360.0	100% input angle adjustment (canceled by ITEM 04 setting)	270.0
07	2	0, 1	Rotating direction *3 0: CW (clockwise) *2 1: CCW (counterclockwise)	0
08	N/A	0, 1, 2	Output range code 0: V1 (-1 – +1V) 1: V2 (-10 – +10V) 2: Z1 (0 – 20mA)	V1: 0 V2: 1 Z1: 2
09	N/A	-15.0 – 115.0	Input indicated in % (of the range set in ITEM 03/04/05/06)	---
10/L	2	-15.0 – 115.0	Output indicated in % with ITEM 01 DATA 1 (of the range set in ITEM 17/18) Loop test output with ITEM 01 DATA 2 ('L' is indicated as ITEM No.) (Use DATA UP/DOWN key to set the output signal.)	---
11	2	-99.99 – 99.99	Output zero adjustment (%) (fine adj. of the value set in ITEM 17)	0.00
12	2	-99.99 – 99.99	Output span adjustment (%) (fine adj. of the value set in ITEM 18)	0.00
13	2	0, 1, 2, 3, 4	Moving average (sampling cycle: 150 msec.) 0: No 1: 4 samples 2: 8 samples 3: 16 samples 4: 32 samples	0
14	2	0, 1 – 60	Power-saving mode 0: Continuous display 1 – 60: Time before display turned off (minutes)	10
15	2	-15.0 – 0.0	Overrange output below 0%	-15.0
16	2	100.0 – 115.0	Overrange output exceeding 100%	115.0
17	2	-1.00 – 1.00	Output code V1 0% output voltage (V) *4	-1.00
18	2	-1.00 – 1.00	100% output voltage (V) *4	1.00
17	2	-10.0 – 10.0	Output code V2 0% output voltage (V) *4	-10.0
18	2	-10.0 – 10.0	100% output voltage (V) *4	10.0
17	2	0.0 – 20.0	Output code Z1 0% output current (mA) *4	4.0
18	2	0.0 – 20.0	100% output current (mA) *4	20.0
19	N/A	---	---	---
20	2	0, 1	Linearization table 0: Disable 1: Enable *5	0
21	2	-15.0 – 115.0	Point 1 input setting (%)	0.0
22	2	-15.0 – 115.0	Point 1 output setting (%)	0.0
23	2	-15.0 – 115.0	Point 2 input setting (%)	0.0
24	2	-15.0 – 115.0	Point 2 output setting (%)	0.0
:	:	:	:	:
83	2	-15.0 – 115.0	Point 32 input setting (%)	0.0
84	2	-15.0 – 115.0	Point 32 output setting (%)	0.0
85	2	0, 1	Inverted output 0: Non-inverted 1: Inverted	0
86	3	0, 1	Reset all settings *6	0
87	N/A	---	ROM version	---

\*1. Press DATA UP key and choose DATA 1. Double-click DATA DOWN key. The display shows DATA 0 after the setting is complete.

\*2. Relative to absolute 0° for the device which is determined with the 0° (%) input setting (ITEM 03).

\*3. Rotating direction (ITEM 07) must be determined before setting the 0° (%) input setting (ITEM 03).

\*4. ITEM 17 < ITEM 18.

\*5. Linearization is disabled with the loop test output.

\*6. Press DATA UP key and choose DATA 1. Double-click DATA DOWN key. The display shows DATA 0 after the initialization is complete.

■ SELECTING INPUT ANGLE RANGE

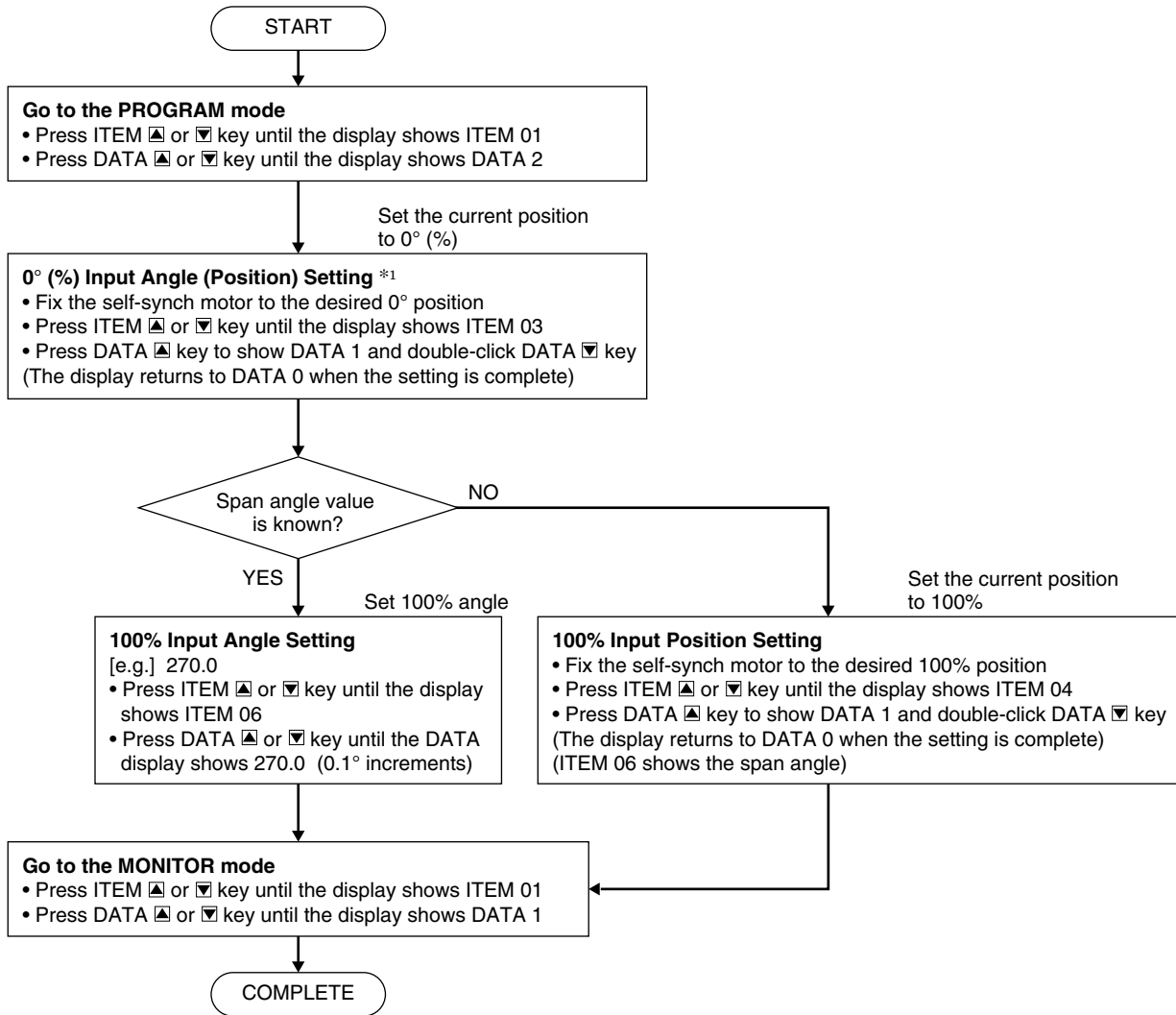

\*The Rotating Angle (ITEM 07) must be determined before the 0° (%) Input Angle (Position) Setting (ITEM 03).

■ 0° (%) INPUT FINE ADJUSTMENT

ITEM 05 shows deviation in angle between the MXS's absolute 0° and 0° (%) Input Angle setting with ITEM 03. Since the MXS's absolute 0° cannot be changed, fine adjustment of the 0° (%) setting with ITEM 03 is performed by adding/subtracting the deviation with ITEM 05. If ITEM 04 or 06 (100% input angle) is already set, the 100% angle is also affected by this adjustment. [Example] Shifting (adjusting) +10.0° from ITEM 03 setting

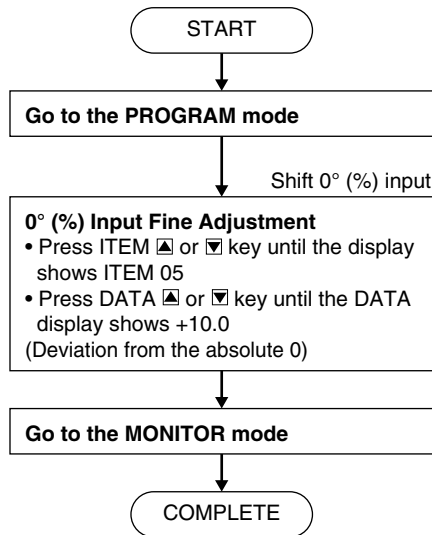

■ LOOP TEST OUTPUT

The loop test output is enabled when ITEM L (10) is selected in the PROGRAM mode. [Example] Loop test output 90.0%

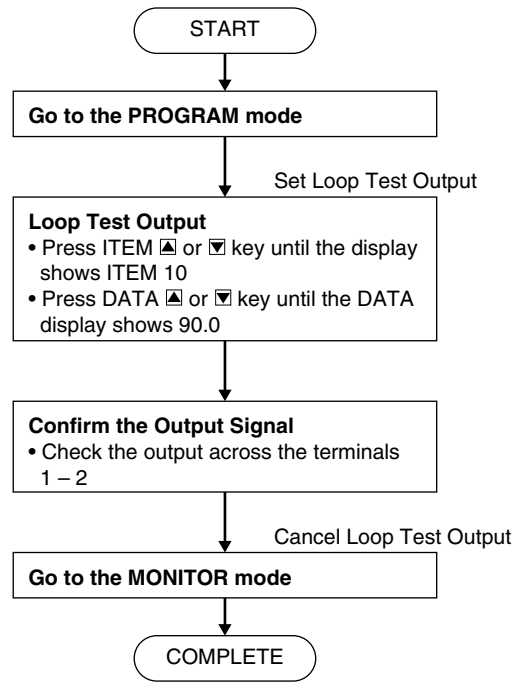

■ SELECTING OUTPUT RANGE

[Example] Output range -10.0 to 0.0V

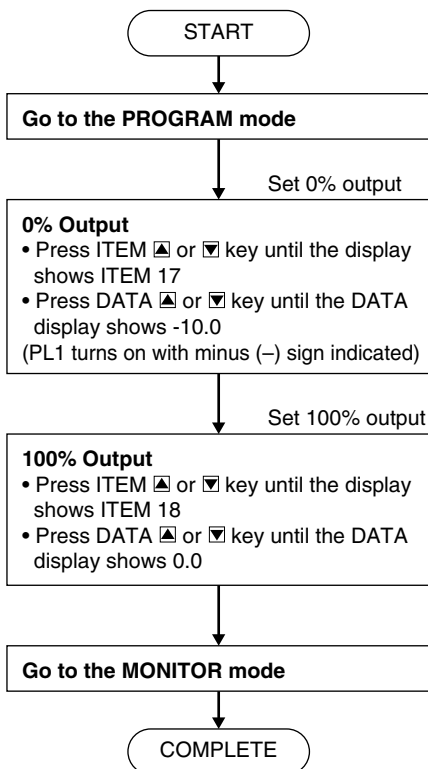

Selected range is available after the power supply is reset.

■ LINEARIZATION TABLE

Max. 32 calibration points defined by sets of input and output values can be programmed. Use only necessary number of points, arranged in order from the smallest input value.

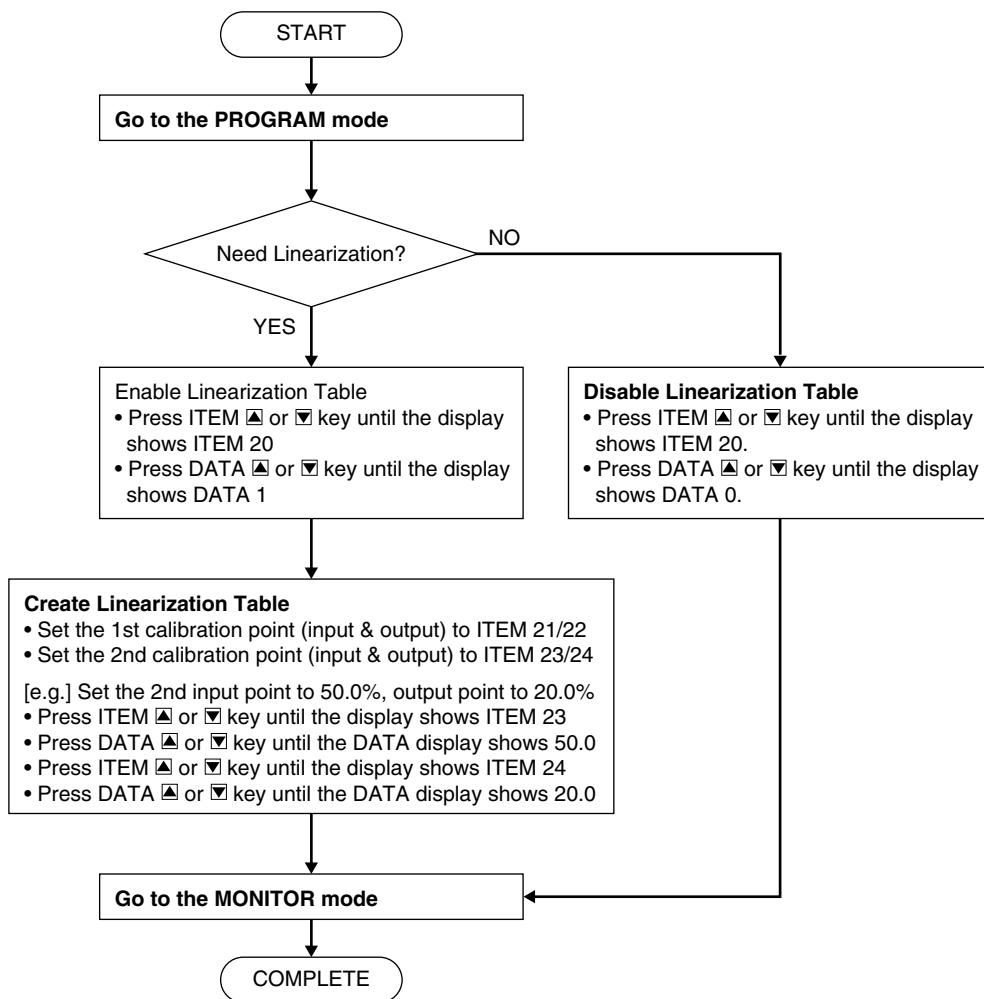
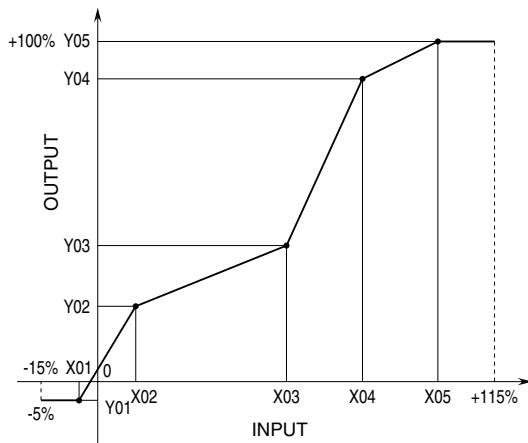

## ■ RESET ALL SETTINGS

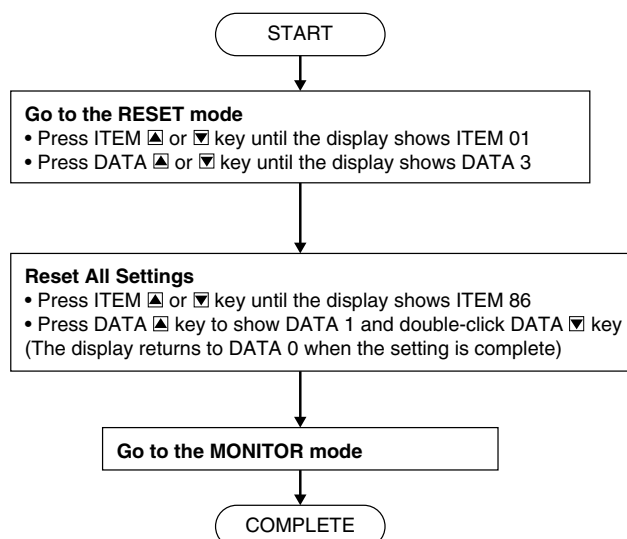

## ■ PROGRAMMING ERROR LED, PL2

When the PL2 is turned on, identify the cause or error with ITEM 02 (Status Indication)

REF.	ERROR
0	Normal status
17	Output range setting: 0% Setting > 100% Setting See ITEM 17 / 18.
99	Memory error: Initialize all the settings of the unit by operating ITEM 86 and program the unit again.

## CHECKING

- 1) Terminal wiring: Check that all cables are correctly connected according to the connection diagram.
- 2) Input signal and power input voltage: Check wiring across MXS and self-synch as follows; terminal 3 – S1, terminal 4 – S2, terminal 5 – S3, terminal 7 – R1, and terminal 8 – R2.

Be sure that the connection for R1 and R2 of the self-synch. When the connection is reversed, the signal conditioner output will be shifted by 180°.

- 3) Output: Check that the load resistance meets the described specifications.

## MAINTENANCE

Regular calibration procedure is explained below:

### ■ CALIBRATION

Warm up the unit for at least 10 minutes. Apply 0%, 25%, 50%, 75% and 100% input signal. Check that the output signal for the respective input signal remains within accuracy described in the data sheet. When the output is out of tolerance, recalibrate the unit as explained earlier (ITEM 11 and 12).

## LIGHTNING SURGE PROTECTION

We offer a series of lightning surge protector for protection against induced lightning surges. Please contact us to choose appropriate models.