

<p><b>DC ALARM</b> (thumbwheel switch adjustment, CE)</p>	<p>MODEL <b>M8SED1</b></p>
---	----------------------------

**BEFORE USE ....**

Thank you for choosing us. Before use, please check contents of the package you received as outlined below. If you have any problems or questions with the product, please contact our sales office or representatives.

**■ PACKAGE INCLUDES:**

Signal conditioner .....(1)

**■ MODEL NO.**

Confirm Model No. marking on the product to be exactly what you ordered.

**■ INSTRUCTION MANUAL**

This manual describes necessary points of caution when you use this product, including installation, connection and basic maintenance procedures.

**POINTS OF CAUTION**

**■ CONFORMITY WITH EU DIRECTIVES**

- Functional insulation is maintained between the input and output.
- The equipment must be mounted inside a panel.
- The actual installation environments such as panel configurations, connected devices, connected wires, may affect the protection level of this unit when it is integrated in a panel system. The user may have to review the CE requirements in regard to the whole system and employ additional protective measures\* to ensure the CE conformity.
- \* For example, installation of noise filters and clamp filters for the power source, input and output connected to the unit, etc.
- Install lightning surge protectors for those wires connected to remote locations.

**■ POWER INPUT RATING & OPERATIONAL RANGE**

- Locate the power input rating marked on the product and confirm its operational range as indicated below:  
24V DC rating: 24V ±10%, approx. 60mA

**■ GENERAL PRECAUTIONS**

- Before you remove the unit or mount it, turn off the power supply and input signal for safety.

**■ ENVIRONMENT**

- Indoor use.
- When heavy dust or metal particles are present in the air, install the unit inside proper housing with sufficient ventilation.
- Do not install the unit where it is subjected to continuous vibration. Do not subject the unit to physical impact.
- Environmental temperature must be within 0 to 55°C (32 to 131°F) with relative humidity within 30 to 95% RH in order to ensure adequate life span and operation.
- Be sure that the ventilation slits are not covered with cables, etc.

**■ WIRING**

- Do not install cables close to noise sources (relay drive cable, high frequency line, etc.).
- Do not bind these cables together with those in which noises are present. Do not install them in the same duct.

**■ AND ....**

- The unit is designed to function as soon as power is supplied, however, a warm up for 10 minutes is required for satisfying complete performance described in the data sheet.

**COMPONENT IDENTIFICATION**

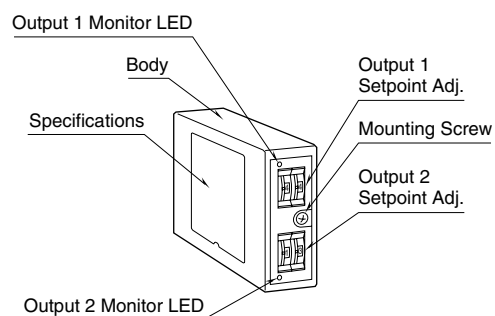

**INSTALLATION**

Use Installation Base (model: M8BSx).

## TERMINAL CONNECTIONS

Connect the unit as in the diagram below.

### EXTERNAL DIMENSIONS unit: mm (inch)

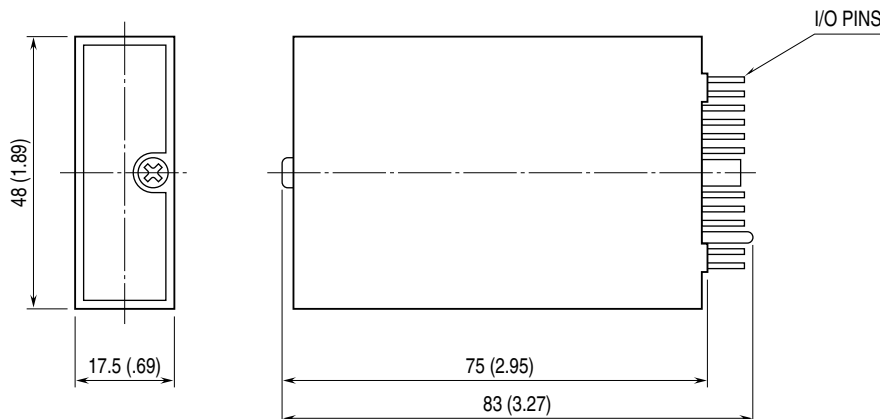

### CONNECTION DIAGRAM

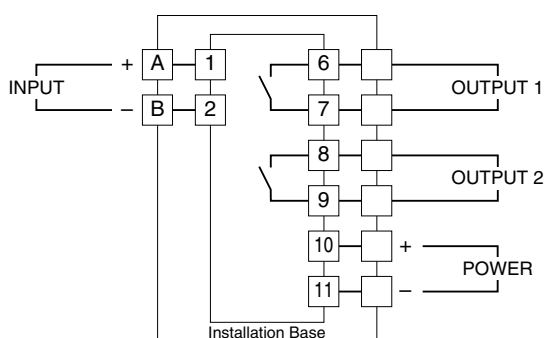

## CHECKING

- 1) Terminal wiring: Check that all cables are correctly connected according to the connection diagram.
- 2) Power input: Check the power input voltage.
- 3) Input: Check that the input signal is within 0 – 100% of the full-scale.
- 4) Check that the output load is 60V DC/15W at the maximum. For maximum relay life with inductive loads, external protection is recommended.

When used with a multi-channel installation base (e.g. M8BS1-16), the ratings derated as following.

Terminal block type: 30V DC @ 0.25A

Cable connector type: 24V DC @ 50mA

## ALARM TRIP OPERATION

	TRIP ACTION	OUT CODE	POWERED		UNPOWERED
			INP < SET	INP > SET	
OUT 1	Hi	1	OFF	ON	OFF
	Hi	2	ON	OFF	ON
OUT 2	Lo	1	ON	OFF	OFF
	Lo	2	OFF	ON	ON

## ADJUSTMENT PROCEDURE

Turn the front thumbwheel SW to indicate desired set-points in %.

Output 1 is for high trip, while Output 2 is for low.

Monitor LED turn ON when the coil is energized; Output 1 coil is energized when the input is above the setpoint, while Output 2 coil is when the input is below the setpoint.

Relay contact turns ON when the coil is energized with Output Code 1, de-energized with Output Code 2.

## MAINTENANCE

Regular calibration procedure is explained below:

### CALIBRATION

Warm up the unit for at least 10 minutes.

#### Hi Setpoint

Increase the input signal from a value lower than the setpoint and check that the relay trips at the setpoint.

#### Lo Setpoint

Decrease the input signal from a value higher than the setpoint and check that the relay trips at the setpoint.

When the trip points are shifted, please contact our sales office or representatives.

## LIGHTNING SURGE PROTECTION

We offer a series of lightning surge protector for protection against induced lightning surges. Please contact us to choose appropriate models.