

SERVO-TOP II ELECTRONIC ACTUATOR
(rotary type; max. torque 600 N·m)

MODEL

PRP-2

BEFORE USE

Thank you for choosing us. Before use, please check contents of the package you received as outlined below.

If you have any problems or questions with the product, please contact our sales office or representatives.

■ SAFETY PRECAUTIONS

Before use, please read all the following precautions carefully to ensure the safety. These safety precautions, classified into “WARNING” and “CAUTION” according to the degree of damage that each item could cause, are imperative to prevent an accident. After reading, be sure to keep this manual always in a visible and accessible place for the user. **WARNING** Suggesting that failure to observe the precautions could result in death or serious personal injury.

CAUTION Suggesting that failure to observe the precautions could result in personal injury or damage to the property.

△ WARNING
When mounting on a valve, DO NOT lift the actuator with a rope or drape that is wrapped around the hand wheel or its periphery. The hand wheel comes off, and by the heavy actuator dropping, serious injury may be caused.
Power fuse: A glass tube power fuse (5.2 dia × 20 mm) of the rating as shown below is incorporated for safety. Be sure to remove the power supply before replacing it. Replacing the fuse without turning off the power supply may cause electric shock. AC power: Medium time lag, M 3A 250V
Remove power supply to the actuator before wiring to it. It may cause electric shock.
DO NOT dismantle or remodel the product. It may cause electric shock or injury.
DO NOT step onto the actuator. DO NOT rest a heavy object on or against it. It may cause injury.
When installing the PSN outdoor or where it is exposed to rain or water drops, adequate precaution must be done for preventing water from entering inside through wiring conduits.
△ CAUTION
DO NOT remove the cover of actuator. It may cause electric shock or injury.
The adjustments which are paint locked are for factory use only and should be changed only by our qualified personnel. We are not liable for any malfunction or inconvenience caused by unauthorized change of them by the user. Otherwise it may cause breakdown.

■ PACKAGE INCLUDES:

- SERVO-TOP II body(1)
- Spare fuse(1)
- Note: Yoke and other components necessary to attach the PRP-2 to a valve are to be provided by the customer.

■ MODEL NO.

Confirm Model No. marking on the product to be exactly what you ordered.

■ INSTRUCTION MANUAL

- This manual describes necessary points of caution when you use this product, including installation and connection, hardware setting, and basic maintenance procedures.
- When you need to change software settings, please refer to the Operation Manual for Model PU-2x* (EM-9255), Section B. The PRP-2 is factory adjusted and calibrated according to the Ordering Information included in the product package. If you do not need to change the pre-adjusted setting, you can skip the sections on PU-2x programming in this manual and the Operation Manual for Model PU-2x.

* PU-2x: Programming Unit (optional)

POINTS OF CAUTION

■ CONFORMITY WITH EU DIRECTIVES

- This equipment is suitable for Pollution Degree 2 and Installation Category II (transient voltage 2500V). Reinforced insulation (I/O signal or seq. signals or metallic housing to power: 300V) is maintained. Prior to installation, check that the insulation class of this unit satisfies the system requirements.
- Altitude up to 2000 meters.
- The equipment must be installed such that appropriate clearance and creepage distances are maintained to conform to CE requirements. Failure to observe these requirements may invalidate the CE conformance.
- Install lightning surge protectors for those wires connected to remote location. Refer to “LIGHTNING SURGE PROTECTION” section below.

■ POWER INPUT RATING & OPERATIONAL RANGE

- Locate the power input rating marked on the product and confirm its operational range as indicated below:
 - 100 – 120V AC rating: 90 – 132V, 47 – 66 Hz, approx. 180 VA
 - 200 – 240V AC rating: 180 – 264V, 47 – 66 Hz, approx. 180 VA

■ HUNTING

- The mode that the unit is operating at open/close operation or middle position with long term or intermittently. A rough indication of no hunting range is not more than ‘13 times operation/1 minute’ (duty 50%).

GENERAL PRECAUTIONS

- Remove main power supply to the actuator before wiring to it.
- DO NOT install signal wires and power supply wires together in one duct because it may cause a malfunction due to inductive noises. If they must be installed together, use shielded cables.
- If input signals are to be turned on/off with power supplied to the actuator, be sure to set the output stem action at input failure.
- DO NOT loosen the screws fixing the angle sensor inside the actuator.

ENVIRONMENT

- Inside building. If outside, keep away from direct sunlight.
- Operating temperature -20 to +55°C (-4 to +131°F). When the ambient temperature can be less than 0°C (32°F), keep the power on except during installation or maintenance.
Operating humidity 30 to 85% RH (non-condensing)
- The unit does not endure all vibration at installation site. Even if that is low vibration, the unit cannot be guaranteed over a long period. Please use after evaluation with customer's installation environment. (Particularly avoid using at the place where there is water hammer, steam hammer or cavitation on the valve side.)
- The actuator must be installed in a place where maintenance and inspection can be conducted. Leave spaces of at least 20 cm (7.9 in.) for maintenance and inspection above the unit and around its terminal cover.
- Keep away from hazardous atmosphere such like explosive or corrosive gases.

SOUND ACCOMPANYING MOTOR ROTATION

- The PRP-2's stepping motor inherently generates whistling sound during normal operation according to its rotating frequency, larger with lower frequencies. Please do not be alarmed.

PID CONTROL SIGNAL

- Choose PID parameters carefully so that the MV remains as stable as possible. Unstable control shortens the life of actuator and valve.

RUBBER PACKING

- Confirm that the rubber packing is correctly attached in place when you close the terminal cover after wiring or adjustments.

SCREW TORQUE

- The torque for tightening screws for the cover is between 2.4 – 3.1 N·m (1.8 – 2.3 ft·lbf). The screws must be tightened evenly and crosswise in several steps to prevent uneven clamping.

DESIGNING YOKE

- When a foreign object is caught in the valve, torque greater than the maximum in the Table 4 and 5 could be applied to the yoke. Taking it into account, provide enough strength when designing mechanical components such like the yoke.
- When the PRP-2 is used on a steam stream in temperature control, its temperature may rise beyond ambient temperature caused by a heat conducted or radiated from piping. Use a longer yoke for effective heat dissipation and apply insulation material.

COMPONENT IDENTIFICATION

Figure 1. Component Identification

INSTALLATION

Valve, yoke, coupling and other components necessary to connect the PRP-2 to the valve are provided by the customer. DO NOT CHANGE the ex-factory settings of the PRP-2. The following procedure should be done with the power supply removed, except when otherwise specified. The following is the general procedure for mounting the actuator to a valve with a yoke and coupling.

PROCEDURE FOR REVERSE OPERATION

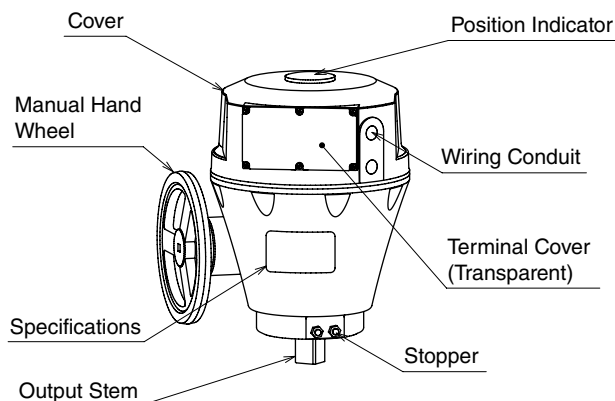
(e.g. 4 to 20 mA input)

- 1) Supply power to the PRP-2, and apply 4 mA DC to turn the output stem clockwise (seeing from the indicator) to the fully closed position.
- 2) Turn the valve stem to the fully closed position (fully clockwise).
- 3) Set the yoke to the valve side.
- 4) Set the coupling to the valve stem and fit the PRP-2 output stem into the coupling. Then fix the yoke and valve temporarily.
- 5) Fix the coupling so that there is no eccentricity between both stems.
- 6) Fix the yoke and valve firmly after checking the eccentricity of both stems again.

ELECTRICAL CONNECTION

Remove the terminal cover and wire to the terminal block according to Figure 2.

The PRP-2 requires the power supply voltage (1 – 2) and input signal (3 – 4) connections for operating.

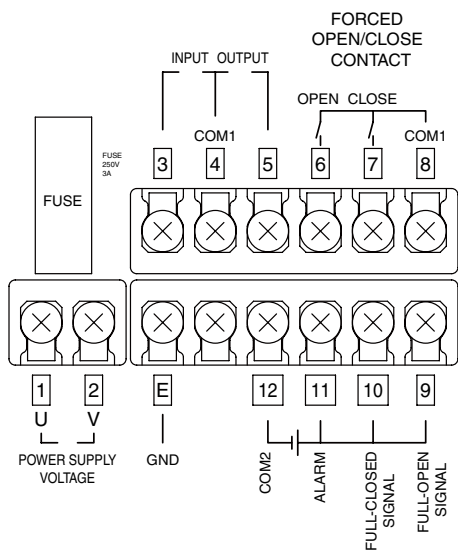

Terminal Block Characteristics

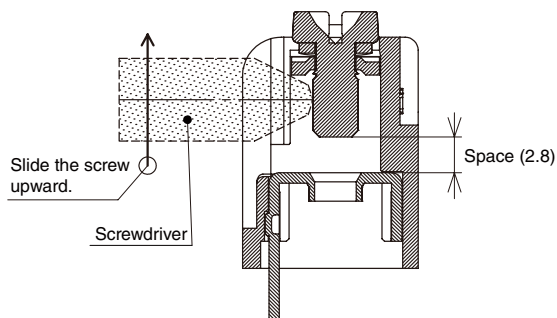

Solderless Terminal Size

- Spade Terminal

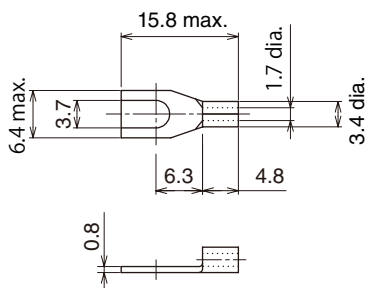

- Ring Terminal

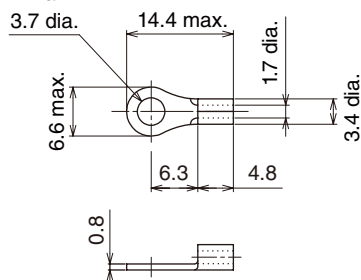

Figure 2. Connection Diagram & Applicable Solderless Terminal

ADJUSTMENT PROCEDURE

FULL-CLOSED POSITION/ANGLE

[Via manual hand wheel]

- 1) Apply power supply voltage.
- 2) Turn ON the SW1-8.
- 3) Adjust the output stem's full-closed position. Turning the hand wheel counterclockwise turns the output stem in the closing direction. (Be sure to check the indicator to determine the full-close position.)

Table 1. FULL-CLOSED POSITION AND ANGLE ADJUSTMENT

Manual hand wheel's rotation angle	Output stem's operating angle
Approx. 6°	0.1°
Approx. 60°	1°
360°	Approx. 5.9°
Approx. 15 turns plus 90°	90°

Note: Rough indication

- Remove the terminal cover.

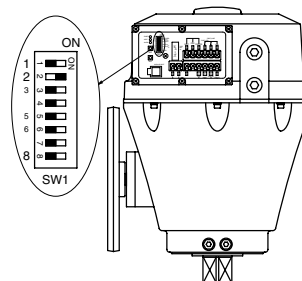

- Turn ON the SW1-8.

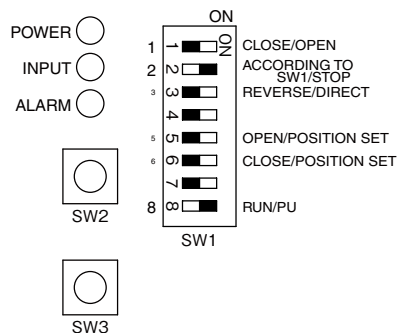

- Turn the manual hand wheel.

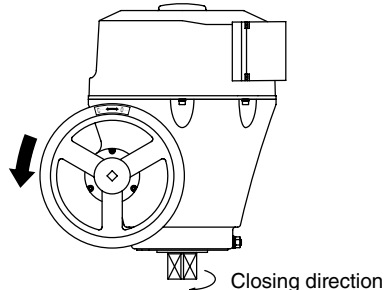

Figure 3. Adjustments, Details

- 4) Return the SW1-8 to OFF position when the adjustment is complete.
- 5) Apply input signals (range: 4 – 20 mA DC).

Confirm that there is no problem with the output stem's full-closed position adjusted and the angle at which the output stem stops with 4 mA DC input.

■ OUTPUT STEM ACTION AT INPUT FAILURE

(Standard setting is Table 2-1.)

Table 2. OUTPUT STEM ACTIONS & SWITCH POSITIONS

OUTPUT STEM	SW1
1 Stops at once.	
2 Automatically reaches full-closed position.	
3 Automatically reaches full-open position.	

■ ACTUATOR ACTION (SW1-3)

Use SW1-3 for switching the actuator action. It is set to “REVERSE” as standard setting. Refer to Table 3.

Table 3. ACTUATOR ACTION

MODE	SW1-3	ACTION
Reverse	OFF	Output stem turns counterclockwise with decreasing input. (valve closes)
Direct	ON	Output stem turns clockwise with decreasing input. (valve opens)

■ FULL-OPEN/CLOSED POSITIONS

- 1) Turn ON the SW1-8 in order to put the PRP-2 in the local calibration mode, and the input signal is disregarded.
- 2) Turn ON the SW1-5 and adjust the full-open position pressing OPEN/CLOSE control buttons.
- 3) When the output stem reaches a desired position, turn OFF the SW1-5. The position is memorized as the full-open position.
- 4) Turn ON the SW1-6 and adjust the full-closed position pressing OPEN/CLOSE control buttons.
- 5) When the output stem reaches a desired position, turn OFF the SW1-6. The position is memorized as the full-closed position.
- 6) Turn OFF the SW1-8 in order to put the PRP-2 in the operating mode. Apply input signals and confirm the full-open/closed positions.

Note: The operating angle between the Full-open and Full-close must be 45° or more.

PU-2x ADJUSTMENTS

■ DISPLAY

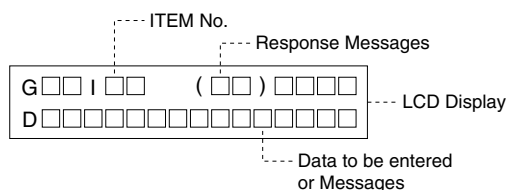

• Response Messages

- NG: No good
The PU-2x may not be securely connected. Check connection of the modular jack.
- ER: Communication error
Turn the SW1-8 ON.

• Data Indicator

- OK: OK
- DATA-ERR: Invalid data input
- NON-ITEM: ITEM No. not applicable

■ PROGRAMMABLE ITEMS

Table 4. PROGRAMMABLE ITEMS

ITEM NO.	ITEM	USABLE RANGE	MINIMUM INCREMENT	FACTORY DEFAULT
10	Full-open position	45 – 100 (%)	0.1	95.0
11	Full-closed position	0 – 55 (%)	0.1	5.0
12	Open side limit	75 – 105 (%)	0.1	100
13	Closed side limit	-5 – 25 (%)	0.1	0
14	Full-open output	75 – 100 (%)	0.1	97.7
15	Full-closed output	0 – 25 (%)	0.1	2.3
19	Opening/closing speed	1, 3, 8, 12, 20	1	12
20	Dedband	0.1 – 5 (%)	0.1	0.3
21	Restart limiting timer	0 – 30 (sec.)	0.1	2

Note: The unit is not shown on the PU-2x display.

■ ROM VERSION INDICATION

Press ITEM 99 in the local calibration mode in order to display the ROM version of the PRP-2.

■ HOW TO PROGRAM THE PRP-2

- 1) Apply power supply voltage to the PRP-2.
- 2) Turn ON the SW1-8 in order to put the PRP-2 in the local calibration mode, and the input signal is disregarded.
- 3) Connect the modular jack cord of the PU-2x to the PRP-2. ITEM display is blank.
- 4) Indicating Current Setting
Key in the ITEM No. that you want to check. (N = 0 to 9)
Press [ITEM] [N] [N].
- 5) Indicating New ITEM No.
Press [ITEM] [N] [N] or press [UP] or [DOWN].
- 6) Modifying Current Setting
Display the ITEM No. that you want to change, and press [DATA], new setting, and [ENTER].
If an irrelevant setting is entered, the PU-2x indicates "DATA-ERR" on its message display. Key in an appropriate setting again.
- 7) Remove the modular jack cord of the PU-2x.
- 8) Turn OFF the SW1-8 in order to return the PRP-2 in the operating mode. Apply input signals and confirm every setting.

Remark 1: DO NOT remove power to the PRP-2 with the PU-2x connected to it.

Remark 2: Be sure to remove the PU-2x before driving the motor (in the operating mode).

■ EXPLANATIONS ABOUT THE PROGRAMMABLE ITEMS

- 1) Full-Open/-Closed Positions (ITEM No.10, 11)
Key in a percentage value within 0% for the turned fully CCW (close), and 100% for turned fully CW (open).
Note: The operating angle between the Full-open and Full-close must be 45° or more.
- 2) Open/Closed Side Limits (ITEM No.12, 13)
The adjustable ranges shown in Table 4 are applicable against the angle determined by the full-open/-closed positions as 100%.
- 3) Full-Open/-Closed Outputs (ITEM No.14, 15)
The adjustable ranges shown in Table 4 are applicable against the angle determined by the full-open/-closed positions as 100%.
- 4) Opening/Closing Speed Limit (ITEM No.19)
Opening/closing speed limit can be changed. Set it taking into account the required torque and referring to Table 5.

Table 5. PRP-2 OPENING/CLOSING SPEED

SPEED SCALE	OPERATION TIME [sec./90°]	ALLOWABLE TORQUE [N·m]	RESTRAINT TORQUE* [N·m]
1	231	600	700
3	114		
8	64		650
12	50		
20	34		

- 5) Deadband (ITEM No.20)

Set deadband for the maximum operating angle. Setting range is 0.1 to 5%.

Note: Setting a larger value makes the resolution worse.

- 6) Restart Limiting Timer (ITEM No.21)

The timer is provided to protect the motor from overheating, preventing it from restarting for a certain interval once the motor has been stopped within deadband.

When the high temperature protection is activated in a high temperature ambient, adjust the timer to a longer interval.

Adjustable range is within 0 to 30 sec.

PROTECTIVE FUNCTIONS

■ ERROR DETECTION

- When the position signal is deviated from the input signal but the output stem is stuck due to overload or certain malfunction, the PRP-2 repeats starting the motor at the maximum torque for several times. If the stem is still stuck after that, the PRP-2 outputs an alarm signal (LED turned ON) and stops power supply to the motor.
- In order to reset the PRP-2, apply several times 0% and 100% input signals in turn, or turn off and on the power supply.
- In case the alarm is ON frequently, check for foreign obstacles in the valve, inappropriate adjustments, or re-tightened gland packing or other possible causes of the overload.
Be sure to remove the cause of alarm in order to ensure appropriate life span.

■ ABNORMAL TEMPERATURE INCREASE PROTECTION

- When the incorporated temperature sensor detects an abnormal temperature increase in the motor, the PRP-2 outputs an alarm signal (LED blinks in 0.5-sec. ON – 0.5-sec. OFF sequence) and stops power supply to the motor until the temperature decreases to an acceptable level.
- The PRP-2 is designed to automatically recover power supply to the motor. However, it takes longer to recover normal operation when ambient temperature is higher.

■ PROTECTIVE FUSE

- A fuse is incorporated for protection against overcurrent in the control PCB and motor.
- If the power LED does not turn on with the power supplied to the actuator, check the fuse status.
- If a replaced fuse is blown quickly, it is possible that the control PCB and/or motor are damaged. Consult us or our representative.

■ MOTOR PREHEATING

When the PRP-2 detects a temperature lower than 0°C or 32°F (approximate) on the surface of its motor, the PRP-2 supplies current to the motor in order to warm up and maintain its surface temperature at 5°C or 41°F (approximate).

Maintain the power supply ON when the PRP-2 is used in the ambient temperature below 0°C or 32°F.

The power consumption at preheating is approx. 24 VA.

LIGHTNING SURGE PROTECTION

We offer a series of lightning surge protectors for protection against induced lightning surges. Please contact us to choose appropriate models.

MAINTENANCE

For effective use and longer life of the PRP-2, regular checking appropriate for its operating conditions is recommended. Refer to the following table.

ITEM	CHECKING POINT	HOW TO PROCEED
Functioning (E.g. 4 to 20 mA input)	Apply input 4 mA → 12 mA → 20 mA → 12 mA → 4 mA. Check the actuator operations and positions at each input value.	Repair or calibration If the alarm indicator LED is on, check that the valve operates lightly and smoothly.
Abnormal sound	No abnormal sound is heard during operation.	Repair or calibration
Connector Leadwire	The connector is firmly connected. No breakdown of leadwires. The insulation covers are not torn, not bruised.	Repair or calibration
Inside humidity, rust	No condensation. No rust. If there is water inside, check the rubber packing and O-ring.	Removing water or Repair In case of immersion, replace with a new product.
Screws	Check that screws and bolts are securely fastened.	Re-tighten them.
Nut	Check that the nut at the valve stem is not loose.	Re-tighten it and calibrate.

For repair, contact us or representatives.

■ LUBRICATION

There is no need of oiling the PRP-2 in normal operating conditions.

■ REGULAR TEST RUNNING

If the valve is not frequently operated, run a test operation regularly (once a week, for example) to check proper functions.

TROUBLESHOOTING

TROUBLE	POSSIBLE CAUSE	HOW TO PROCEED	
Not functioning	Power and/or input indicator OFF	Power and/or input signal is not supplied.	Check power and input signals, remove the causes of malfunction and secure the signals.
		Wiring error.	Check the wiring.
		Bad contact.	Check the connector and other connecting sections.
		Fuse melted.	Replace it with a new one.
	Power and/or input indicator ON	The actuator is in local calibration mode (SW1-8 ON).	Turn SW1-8 OFF.
		Improper adjustments of full-open/-closed positions.	Adjust the full-open/-closed positions.
		Control PCB damaged.	Repair and calibration.
Unstable functioning	Motor damaged.	Repair and calibration.	
	Abnormality in power voltage or input signal.	Remove the causes of malfunction and secure the signals.	
	Operating speed is too fast.	Secure the required torque by slowing.	
	Power voltage is too low or fluctuating.	Secure the required level of voltage.	
	Input is unstable.	Check the controller and cables. Eliminate noise.	
Alarm indicator ON	Angle sensor is damaged.	Repair and calibration.	
	Overload caused by a foreign object caught in the valve.	Remove the causes of overload.	
Alarm indicator blinking	Actuator mechanism damaged.	Repair and calibration.	
	Motor temperature is abnormally high.	Use the restart limiting timer. Review MV value from the controller.	
	Wiring of the temperature sensor is broken or the connector is detached.	Check the connector and leadwires.	

For repair or parts replacement, contact us or representatives.