

PULSE SCALER (selectable range)	MODEL	PRU
--	-------	------------

BEFORE USE

Thank you for choosing us. Before use, please check contents of the package you received as outlined below. If you have any problems or questions with the product, please contact our sales office or representatives.

PACKAGE INCLUDES:

Signal conditioner (body + base socket).....(1)

MODEL NO.

Confirm Model No. marking on the product to be exactly what you ordered.

INSTRUCTION MANUAL

This manual describes necessary points of caution when you use this product, including installation, connection and basic maintenance procedures.

POINTS OF CAUTION

POWER INPUT RATING & OPERATIONAL RANGE

- Locate the power input rating marked on the product and confirm its operational range as indicated below:
AC power: Rating $\pm 10\%$, 50/60 ± 2 Hz, approx. 2VA
DC power: Rating $\pm 10\%$, approx. 2W

GENERAL PRECAUTIONS

- Before you remove the unit from its base socket or mount it, turn off the power supply and input signal for safety.

ENVIRONMENT

- Indoor use.
- When heavy dust or metal particles are present in the air, install the unit inside proper housing with sufficient ventilation.
- Do not install the unit where it is subjected to continuous vibration. Do not subject the unit to physical impact.
- Environmental temperature must be within -5 to $+60^{\circ}\text{C}$ (23 to 140°F) with relative humidity within 30 to 90% RH in order to ensure adequate life span and operation.

WIRING

- Do not install cables close to noise sources (relay drive cable, high frequency line, etc.).
- Do not bind these cables together with those in which noises are present. Do not install them in the same duct.

AND

- The unit is designed to function as soon as power is supplied, however, a warm up for 10 minutes is required for satisfying complete performance described in the data sheet.
- The PRU's output waveform is not uniform due to its scaling method. The user must be aware that it may be inconvenient for certain types of application.

FILTER

- The PRU is designed to accept at the maximum of 100 kHz, which may cause errors due to chattering in the input pulses.
 Use input relays which do not cause chattering. Other relays could be used only with a CR filter, for 10 Hz at maximum.

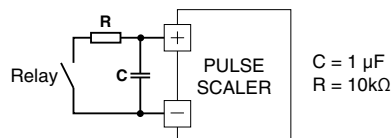

COMPONENT IDENTIFICATION

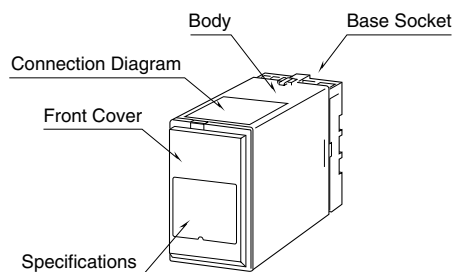

HOW TO OPEN THE FRONT COVER:

Hang your finger on the hook at the top of the front cover and pull.

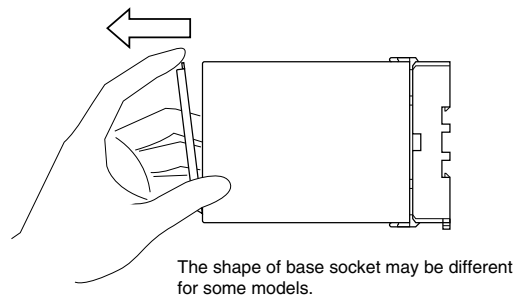

INSTALLATION

Detach the yellow clamps located at the top and bottom of the unit for separate the body from the base socket.

DIN RAIL MOUNTING

Set the base socket so that its DIN rail adaptor is at the bottom. Hang the upper hook at the rear side of base socket on the DIN rail and push in the lower. When removing the socket, push down the DIN rail adaptor utilizing a minus screwdriver and pull.

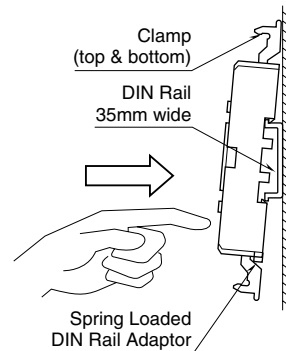

WALL MOUNTING

Refer to "EXTERNAL DIMENSIONS."

Shape and size of the base socket are slightly different with various socket types.

TERMINAL CONNECTIONS

Connect the unit as in the diagram below or refer to the connection diagram on the top of the unit.

EXTERNAL DIMENSIONS unit: mm (inch)

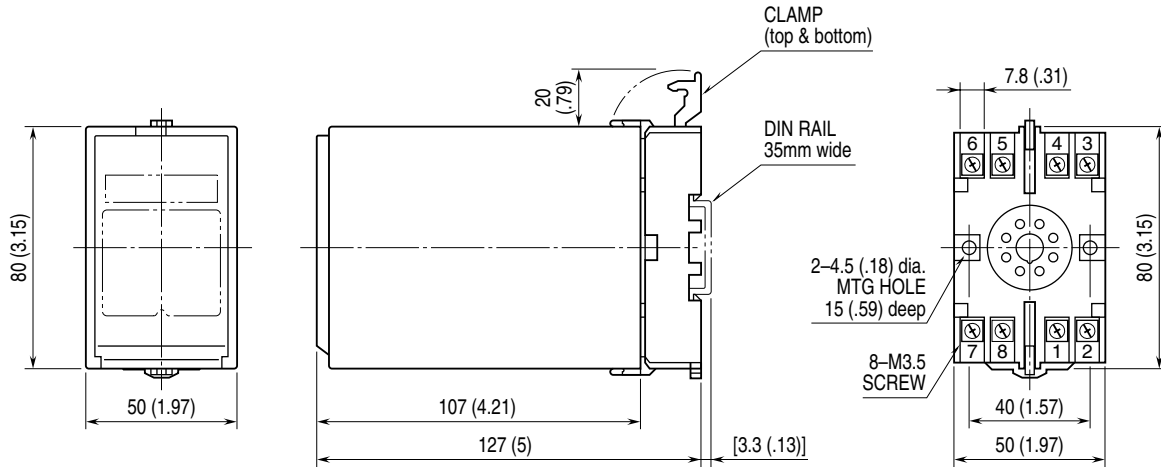

CONNECTION DIAGRAM

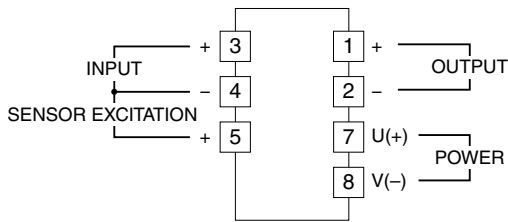

Input Connection Examples

■ Dry Contact

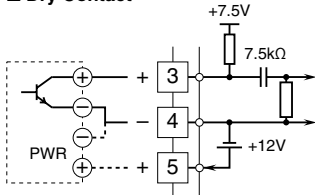

■ Voltage Pulse, Sine Wave

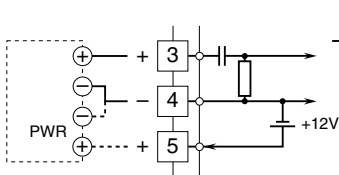

Output Connection Examples

■ Open Collector

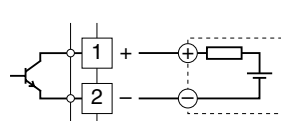

■ Voltage Pulse

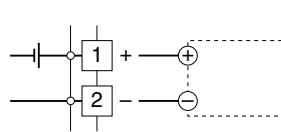

■ Relay Contact

• AC Powered

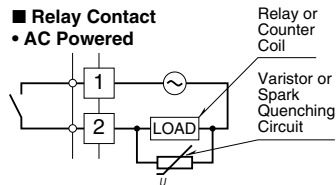

• DC Powered

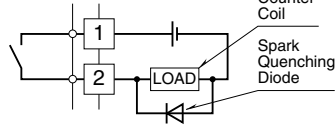

CHECKING

- 1) Terminal wiring: Check that all cables are correctly connected according to the connection diagram.
- 2) Power input voltage: Check voltage across the terminal 7 – 8 with a multimeter.
- 3) Input: Check input terminal 3 – 4 on an oscilloscope. With voltage pulse or sine wave input, check that the pulse amplitude meets the required level according to the following table.

Input Frequency & Required Amplitude

PULSE WIDTH	FREQUENCY	AMPLITUDE
≥ 250 μsec.	0 – 2 kHz	25mVp-p
≥ 25 μsec.	0 – 20 kHz	50mVp-p
≥ 12.5 μsec.	0 – 40 kHz	1Vp-p
≥ 5 μsec.	0 – 100 kHz	5Vp-p

- 4) Output: Check that the load resistance meets the specifications as shown below.

OUTPUT	LOAD REQUIREMENT
Open collector	50V DC @ 50mA max.
5V pulse	600 Ω min.
Relay contact	120V AC @ 200mA (cos φ=1) 240V AC @ 100mA (cos φ=1) 24V DC @ 200mA (resistive load)
24V pulse	800 Ω min.

ADJUSTMENT PROCEDURE

SCALING FACTOR

FRONT VIEW

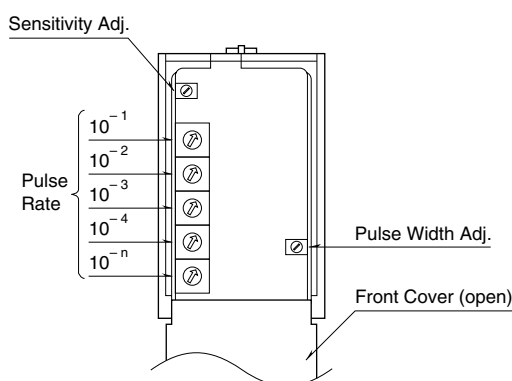

Positions for the rotary switches 10^{-1} through 10^{-n} apply respectively to each digit of the decimals and exponential as shown below.

$$\text{Output Rate} = \text{Input Rate} \times 0. (A)(B)(C)(D) \times 10^{-(E)}$$

where the scaling factor is adjustable from 0.9999×10^0 thr. 0.0001×10^{-6}

[Examples]

Scaling factor 0.1440:

$$(A) = 1, (B) = 4, (C) = 4, (D) = 0, (E) = 0$$

SENSITIVITY ADJUSTMENT

Sensitivity is adjusted with the potentiometer behind the front cover.

Apply maximum frequency with minimum input voltage.

First turn Sensitivity Adj. fully counterclockwise, then gradually turn it clockwise until output is detected.

If the output is still detected when turning Sensitivity Adj. to the fully counterclockwise position, or if the input is open collector or relay contact, leave it at fully counterclockwise position.

The sensitivity can be set to requisite minimum for preventing noise interference.

Single-turn screwdriver adjustment; 25mVp-p to 5Vp-p

For the input pulse width and required level, refer to CHECKING.

OUTPUT PULSE WIDTH ADJUSTMENT

Turn the output pulse width adjuster fully counterclockwise. Then, while applying 100% input, gradually turn the adjuster clockwise until the pulse width is adjusted to such a value that can be read by receiving instrument such as a counter.

Open collector: 5V voltage pulse; 40 μsec. to 0.8 msec.

Relay contact pulse: 24V voltage pulse; 40 msec. to 0.8 sec.

MAINTENANCE

Regular calibration procedure is explained below:

CALIBRATION

Turn off and on the power supply, and wait for 10 seconds or more before applying pulse input. Then, confirm that output pulse is equivalent to the integer part of a value obtained by multiplying the input pulse by the pulse rate.

LIGHTNING SURGE PROTECTION

We offer a series of lightning surge protector for protection against induced lightning surges. Please contact us to choose appropriate models.