

PC RECORDER
(thermocouple or DC input, 8 points; isolated)MODEL **R1MS-GH3****BEFORE USE**

Thank you for choosing us. Before use, please check contents of the package you received as outlined below.

If you have any problems or questions with the product, please contact our sales office or representatives.

This product is for use in general industrial environments, therefore may not be suitable for applications which require higher level of safety (e.g. safety or accident prevention systems) or of reliability (e.g. vehicle control or combustion control systems).

For safety, installation and maintenance of this product must be conducted by qualified personnel.

■ PACKAGE INCLUDES:

PC Recorder(1)
Cable (9-pin D-sub cable, straight type)(1)
CD (software and users manual).....(1)

■ MODEL NO.

Confirm Model No. marking on the product to be exactly what you ordered.

■ INSTRUCTION MANUAL

This manual describes necessary points of caution when you use this product, including installation, connection and basic maintenance procedures. Read also the Users Manual for the software included in the CD for maximum use of the PC Recorder.

POINTS OF CAUTION**■ POWER INPUT RATING & OPERATIONAL RANGE**

- Locate the power input rating marked on the product and confirm its operational range as indicated below:
100 – 240V AC rating: 85 – 264V, 47 – 66 Hz, approx. 9VA
24V DC rating: 24V ±10%, approx. 3.5W

■ GENERAL PRECAUTIONS

- Before you remove the module, turn off the power supply, input signal and output signal for safety.

■ PC RECORDER SOFTWARE

- Use the latest version of PC Recorder Software included in the product package.

■ ENVIRONMENT

- Indoor use.
- When heavy dust or metal particles are present in the air, install the module inside proper housing with sufficient ventilation.
- Do not install the module where it is subjected to continuous vibration. Do not subject the unit to physical impact.
- Environmental temperature must be within -5 to +60°C (23 to 140°F) with relative humidity within 30 to 90% RH in order to ensure adequate life span and operation.
- Be sure that the ventilation slits are not covered with cables, etc.
- Sudden ambient temperature change could increase the cold junction compensation error by the internal terminal temperature sensor. Stabilize the temperature around the terminal block.

■ WIRING

- Wrong connection may damage the module.
- Do not connect cables to moving parts or pull them tightly.
- Do not install cables close to noise sources (relay drive cable, high frequency line, etc.).
- Do not bind these cables together with those in which noises are present. Do not install them in the same duct.

■ AND

- The module is designed to function as soon as power is supplied, however, a warm up for 10 minutes is required for satisfying complete performance described in the data sheet.

PC REQUIREMENTS (provided by the user)

Refer to the MSRPAC-2010 data sheet for the contents of the package and the requirements for the PC to be prepared by the user.

COMPONENT IDENTIFICATION

REAR VIEW

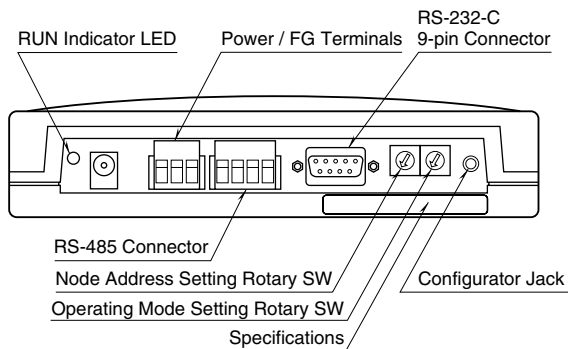

OPERATING MODE

COLD JUNCTION COMP. (T/C)	LINE NOISE FREQUENCY	BURNOUT (T/C)		
		NONE	UP	DOWN
With	50/60 Hz	1	2	3
	50 Hz	4	5	6
	60 Hz	7	8	9
Without	50 Hz	A	B	C
	60 Hz	D	E	F

Note 1: AD conversion rate is half as long as the line frequency.

Note 2: Specifying the exact frequency (50 Hz and 60 Hz) provides better protection than 50/60 Hz setting.

Note 3: Factory default setting is '1.'

INSTALLATION

DIN RAIL MOUNTING

Set the body so that its DIN rail adaptor is at the bottom. Pull down the DIN rail adaptor. Hang the upper hook at the rear side on the DIN rail and push in the lower. Push back the DIN rail adaptor.

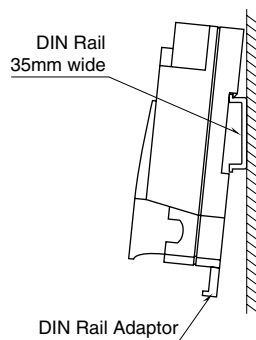

WALL MOUNTING

Set the body so that its DIN rail adaptor is at the bottom. Pull down the DIN rail adaptor. Refer to "EXTERNAL DIMENSIONS."

TERMINAL CONNECTIONS

Connect the unit as in the diagram below.

EXTERNAL DIMENSIONS unit: mm [inch]

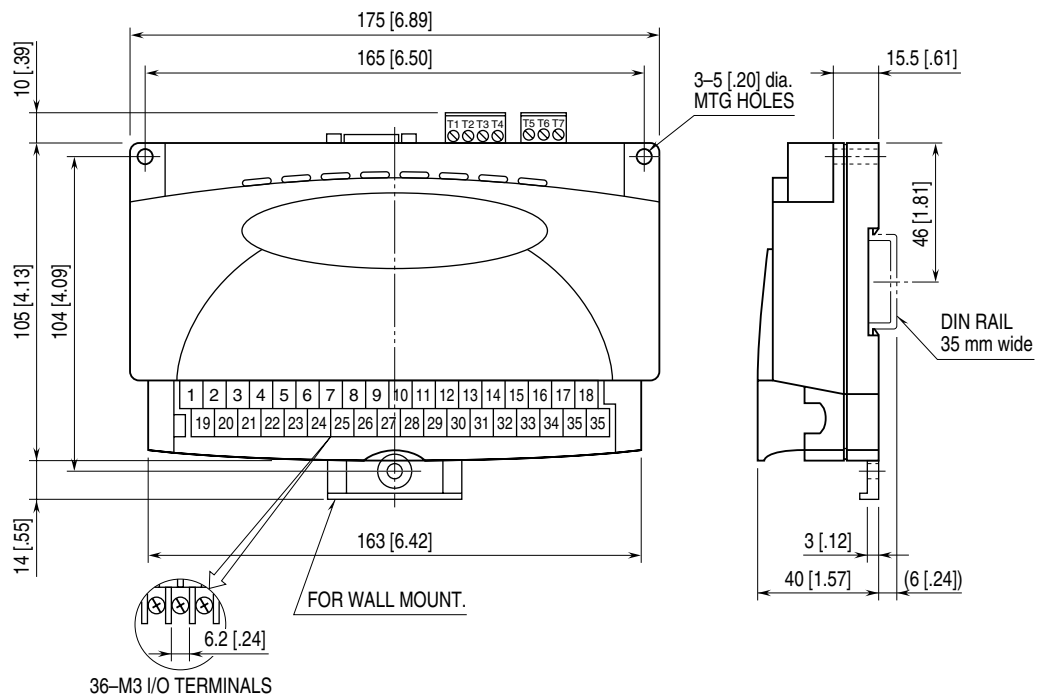

CONNECTION DIAGRAM

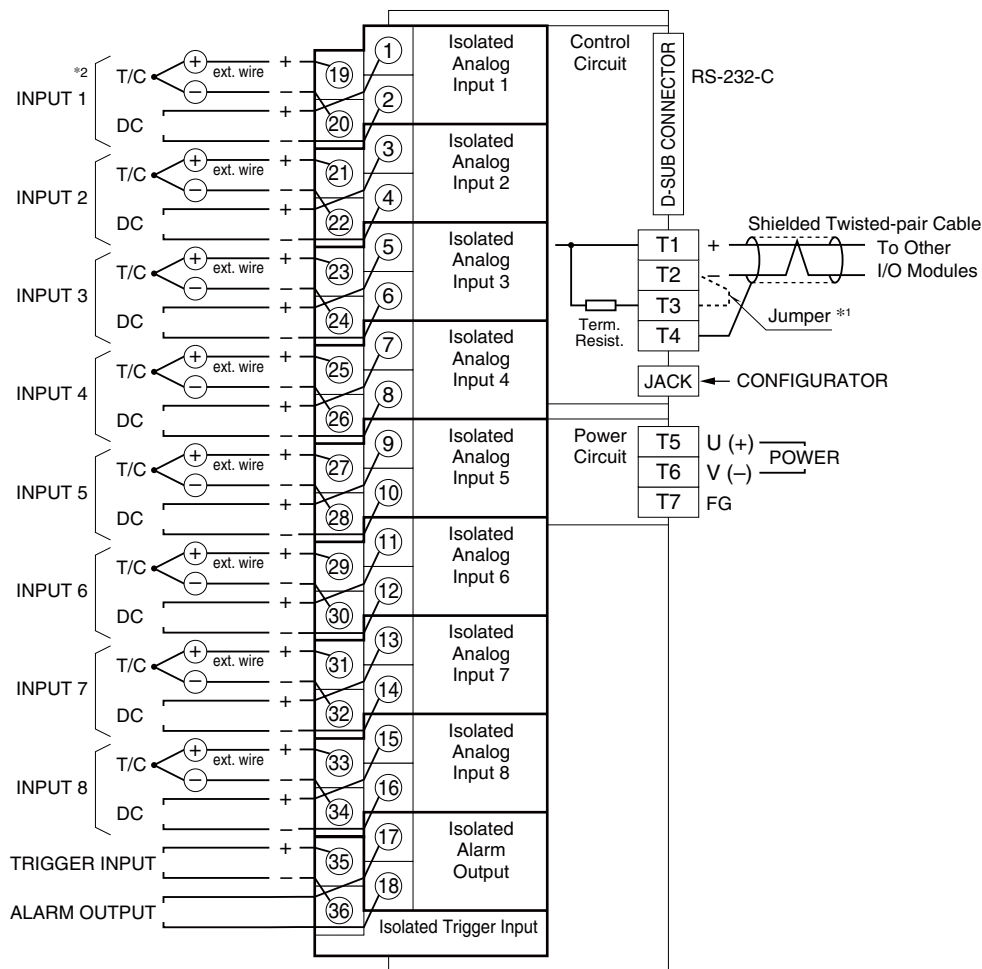

- *1. When the device is located at the end of a transmission line via twisted-pair cable, (when there is no cross-wiring), close across the terminal T2 – T3 with the attached jumper pin (or with a leadwire). When the device is not at the end, remove the jumper pin.
 - *2. Separate sets of terminals for DC and TC are assigned to each channel, however, DO NOT connect to both sets of terminals at once. Duplicate connection may affect measuring accuracies. DC and TC can be mixed among eight channels.
 - Note 1: Be careful to eliminate noise as much as possible by e.g. using shielded cables.
 - Note 2: Be sure to earth the FG terminal and the cable shielding to a most stable earth point in the environment.
 - Note 3: Resistor modules (model: REM3-250) can be used to convert current inputs into voltage. However, use of REM3 is not recommended when TC inputs are mixed because the heat developed on and around the REM3 affects the cold junction compensation performance.
- Caution: FG terminal is NOT a protective conductor terminal.

RS-232-C INTERFACE



ABBR.	PIN NO.	EXPLANATION OF FUNCTION
BA (SD)	2	Transmitted Data
BB (RD)	3	Received Data
AB (SG)	5	Signal Common
CB (CS)	7	Clear to Send
CA (RS)	8	Request to Send
	1	Not Used.
	4	DO NOT connect. Connecting may cause malfunctions.
	6	
	9	

RS-232-C CABLE

- Use a 'Straight' cable to connect the R1MS to a PC if not with the cable included in the product package.
- For connecting the R1MS to the R1M or the R2K-1 via RS-232-C, the RS-232-C cable must satisfy the following conditions:
 - (1) Includes the connections shown with solid lines in the figure below.
 - (2) Pins No. 8 are not connected between each other. (May cause breakdowns.)
 'Interlink' or 'Reverse' cables are usually applicable.

Pin Assignments

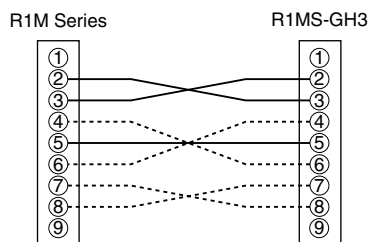

The above connection including solid and broken lines is an example of 'Interlink' cable.

WIRING INSTRUCTIONS

■ M3 SCREW TERMINAL (Input signal, alarm output)

Torque: 0.6 N·m

■ SOLDERLESS TERMINAL

Refer to the drawing below for recommended ring tongue terminal size. Spade tongue type is also applicable.

Applicable wire size: 0.75 to 1.25 mm² (AWG19 to 16)

Recommended manufacturer: Japan Solderless Terminal MFG.Co.Ltd, Nichifu Co.,ltd

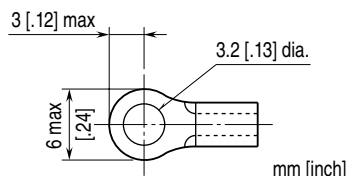

■ EURO TYPE CONNECTOR TERMINAL (Power input, Modbus)

Applicable wire size: 0.2 to 2.5 mm² (AWG24 to 12)

Stripped length: 7 mm

COMMUNICATION CABLE CONNECTIONS

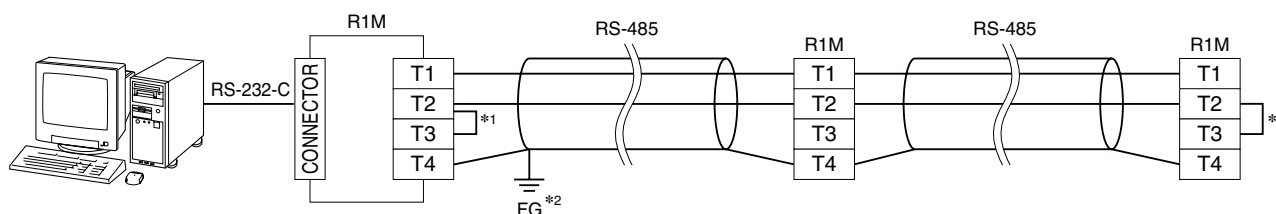

*1. Internal terminating resistor is used when the device is at the end of a transmission line.

*2. Install shielded cables to all sections and ground them at single point.

CHECKING

- 1) Terminal wiring: Check that all cables are correctly connected according to the connection diagram.
- 2) Power input: Check supply voltage.
- 3) Input: Check that the input is within 0 – 100% of full-scale.

ADJUSTMENT PROCEDURE

This unit is calibrated at the factory to meet the ordered specifications, therefore you usually do not need any calibration.

MAINTENANCE

Regular calibration procedure is explained below:

■ CALIBRATION

Warm up the unit for at least 10 minutes. Apply 0%, 25%, 50%, 75% and 100% input signal. Check that the output signal for the respective input signal remains within accuracy described in the data sheet. When the output is out of tolerance, please contact our sales office or representatives.