

VALVE POSITIONER MODULE
(for 2 systems; built-in SSR)MODEL **R3-MEX2****BEFORE USE**

Thank you for choosing us. Before use, please check contents of the package you received as outlined below.

If you have any problems or questions with the product, please contact our sales office or representatives.

■ PACKAGE INCLUDES:

Valve positioner module.....(1)

■ MODEL NO.

Confirm Model No. marking on the product to be exactly what you ordered.

■ INSTRUCTION MANUAL

This manual describes necessary points of caution when you use this product, including installation, connection and basic maintenance procedures.

POINTS OF CAUTION**■ CONFORMITY WITH EU DIRECTIVES**

- This equipment is suitable for Pollution Degree 2 and Measurement Category II (control output, transient voltage 2500V). Reinforced insulation (feedback potentiometer 1 or feedback potentiometer 2 to control output 1 to control output 2: 300V) is maintained. Prior to installation, check that the insulation class of this unit satisfies the system requirements.
- The equipment must be mounted inside the instrument panel of a metal enclosure.
- Altitude up to 2000 meters.
- The equipment must be installed such that appropriate clearance and creepage distances are maintained to conform to CE requirements. Failure to observe these requirements may invalidate the CE conformance.
- The actual installation environments such as panel configurations, connected devices, connected wires, may affect the protection level of this unit when it is integrated in a panel system. The user may have to review the CE requirements in regard to the whole system and employ additional protective measures to ensure the CE conformity.

■ HOT-SWAPPABLE MODULES

- Replacing the module does not affect other modules on the same base. Thus, the module can be replaced while the power is ON. However, replacing multiple modules at once may greatly change live voltage levels. We highly recommend to replace them one by one.

■ ENVIRONMENT

- Indoor use.
- When heavy dust or metal particles are present in the air, install the unit inside proper housing with sufficient ventilation.
- Do not install the unit where it is subjected to continuous vibration. Do not subject the unit to physical impact.
- Environmental temperature must be within -10 to +55°C (14 to 131°F) with relative humidity within 30 to 90% RH in order to ensure adequate life span and operation.

■ WIRING

- Do not install cables close to noise sources (relay drive cable, high frequency line, etc.).
- Do not bind these cables together with those in which noises are present. Do not install them in the same duct.

■ AND

- The unit is designed to function as soon as power is supplied, however, a warm up for 10 minutes is required for satisfying complete performance described in the data sheet.
- This unit is not designed to be used with the following types of interface modules (models: R3-NC2, R3-NEIP1, R3-NFx, R3-NLx).
- Please use this unit with interface modules (models: R3-NC1, R3-NC3, R3-NDx, R3-NE1, R3-NFL1, R3-NM1, R3-NM4, R3-NP1) of firmware version V2.00 or higher, and interface modules (models: R3-NM3, R3-NML3) of firmware version V1.00 or higher.

INSTALLATION

Use the Installation Base (model: R3-BSx).

COMPONENT IDENTIFICATION

■ FRONT VIEW

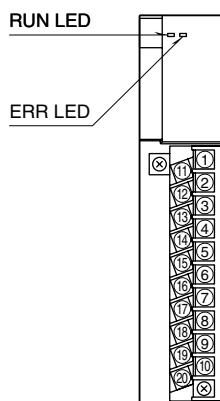

■ STATUS INDICATOR LED

RUN indicator: Bi-color (red/green) LED;

Red when the bus A operates normally;

Green when the bus B operates normally;

Amber when both buses operate normally.

ERR indicator: Green LED turns on in normal operating conditions.

PC CONFIGURATOR

The following parameter items can be configured with the PC configurator software (model: R3CON). Refer to the users manual of the software for detailed operations.

■ INDIVIDUAL CHANNEL SETTING

PARAMETER ITEM	AVAILABLE RANGE	DEFAULT
Motor Deadlock Detecting Time	60 to 1000 (sec.)	120 (sec.)
Deadband adjustment	0.1 / 0.3 / 0.5 / 0.7 / 1.0 / 1.5 / 2.0 / 3.0 / 5.0 / 8.0 (%)	1.5 (%)
Restart Time	500 to 10000 (msec.)	2000 (msec.)
Ch Enable/Disable	Enable / Disable	Enable

TERMINAL CONNECTIONS

Connect the unit as in the diagram below.

EXTERNAL DIMENSIONS unit: mm (inch)

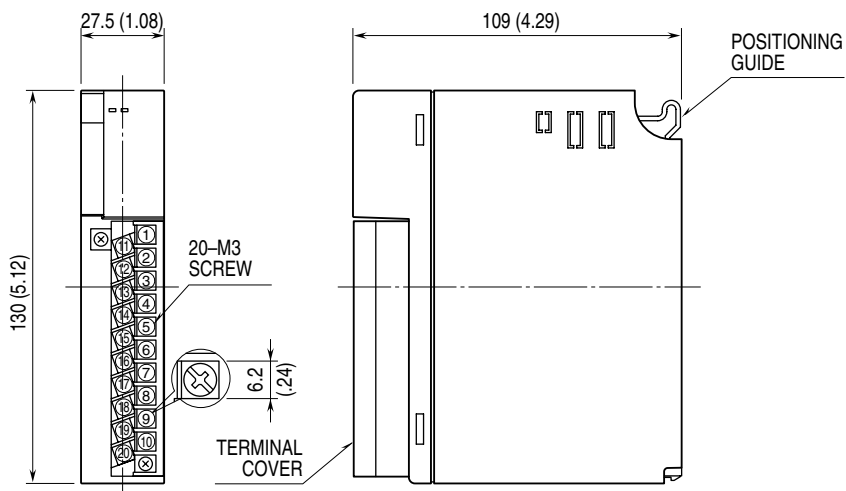

CONNECTION DIAGRAM

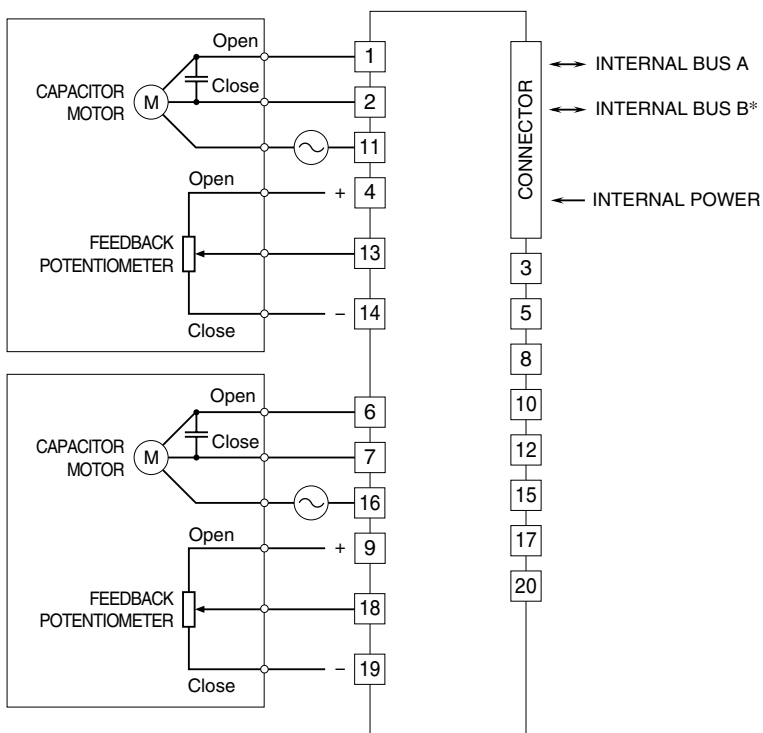

* For dual redundant communication type module only.

DATA ALLOCATION

■ OUTPUT DATA

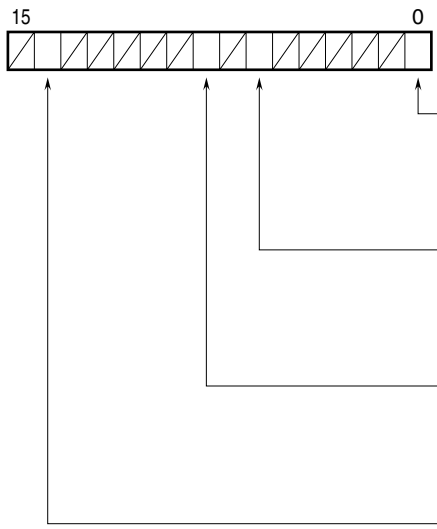
ADDRESS	FUNCTION
n	 <p>Start Running 1 1: Drives motor 1 to the target position. 0: Stops motor 1 (Full position setting function of R3CON can be used)</p> <p>Clear Motor Lock Alarm 1 Setting to "1" clears motor deadlock alarm 1. Confirm motor deadlock alarm has turned "0" before setting "1" on that bit.</p> <p>Start Running 2 1: Drives motor 2 to the target position. 0: Stops motor 2 (Full position setting function of R3CON can be used)</p> <p>Clear Motor Lock Alarm 2 Setting to "1" clears motor deadlock alarm 2. Confirm motor deadlock alarm has turned "0" before setting "1" on that bit.</p>
n+1	<p>Target Position Input 1 Sets the target position for controlling motor 1 via interface module. Signed: 0.1 % Unit: (e.g.: 10 = 1.0 %) Settable range: -0.5 % – +100.5 %</p>
n+2	<p>Target Position Input 2 Sets the target position for controlling motor 2 via interface module. Signed: 0.1 % Unit: (e.g.: 10 = 1.0 %) Settable range: -0.5 % – +100.5 %</p>
n+3	Not in use

Note: "n" represents an address value corresponding to each slot in the Base.

INPUT DATA

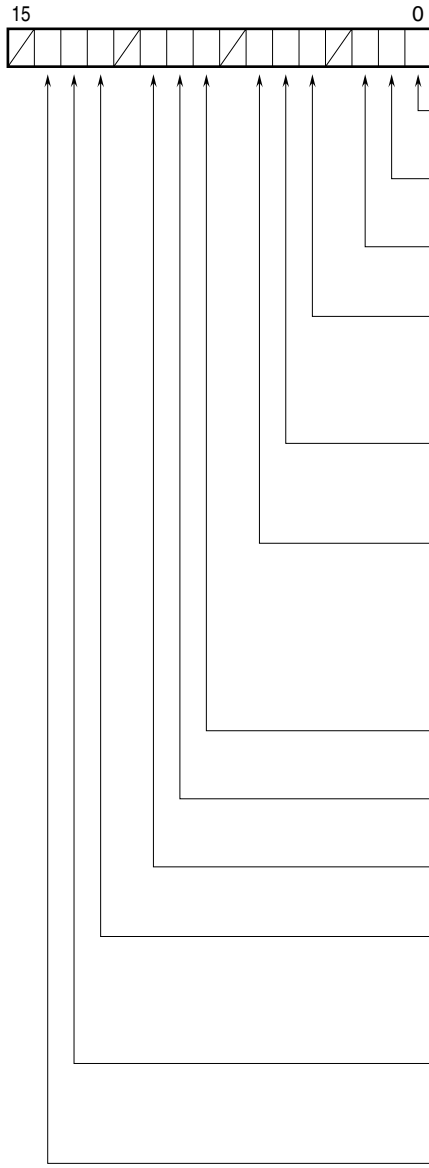
ADDRESS	FUNCTION
n	 <p>Motor 1 Running status 0: Stop 1: Running</p> <p>Motor closing output 1 0: OFF 1: ON Turns "1" while closing</p> <p>Motor opening output 1 0: OFF 1: ON Turns "1" while opening</p> <p>Motor 1 Target position error 0: No error (Target position within the range of -0.5 to +100.5 %) 1: Error (Target position out of range or yet to be set)</p> <p>Motor 1 Full position setting value error 0: No error 1: Error</p> <p>Motor deadlock alarm 1 0: Normal 1: Motor deadlock alarm due to overload etc. Operation is stopped during Motor deadlock alarm. Remove the cause of the alarm before clearing it by Clear motor lock alarm.</p> <p>Motor 2 Running status 0: Stop 1: Running</p> <p>Motor closing output 2 0: OFF 1: ON Turns "1" while closing</p> <p>Motor opening output 2 0: OFF 1: ON Turns "1" while opening</p> <p>Motor 2 Target position error 0: No error (Target position within the range of -0.5 to +100.5 %) 1: Error (Target position out of range or yet to be set)</p> <p>Motor 2 Full position setting value error 0: No error 1: Error</p> <p>Motor deadlock alarm 2 0: Normal 1: Motor deadlock alarm due to overload etc. Operation is stopped during Motor lock alarm. Remove the cause of the alarm before clearing it by Clear motor lock alarm.</p>
n+1	<p>Position output 1 Actual position of the feedback potentiometer 1 is displayed. Signed: 0.1 % Unit: (e.g.: 10 = 1.0 %)</p>
n+2	<p>Position output 2 Actual position of the feedback potentiometer 1 is displayed. Signed: 0.1 % Unit: (e.g.: 10 = 1.0 %)</p>
n+3	Not in use

CHECKING

- 1) Terminal wiring: Check that all cables are correctly connected according to the connection diagram.
- 2) Feedback potentiometer: Check whether voltage across each of the terminals 4 (+) – 14 (–) and 9 (+) – 19 (–) is approx. 3.3V, and voltage across each of the terminals 13 (+) – 14 (–) and 18 (+) – 19 (–) is within 0 to approx. 3.3V.
- 3) Output: Check voltage across the output terminals.

MANUAL OPERATION

Without target position input signal from the interface module, it is possible to drive the motor to the user designated position by turning on Test mode on R3CON.

The test mode setting has priority over the target position set via the interface module. Therefore, be sure to turn off Test mode when the module should be controlled via the interface module.

ADJUSTMENTS

■ FULL-CLOSED POSITION

In order to adjust the full-closed position, open the R3-MEX2 setting window on R3CON, adjust and set the full-closed position.

Settable range: 0 to 25% (factory default: 0%).

■ FULL-OPEN POSITION

In order to adjust the full-open position, open the R3-MEX2 setting window on R3CON, adjust and set the full-open position.

Settable range: 75 to 100% (factory default: 100%).

After the adjustments, check the full-closed position.

If it is shifted from the proper position, make adjustments for the full-closed and full-open positions again.

Repeat the checking, until there is no deviation.

■ DEADBAND

If hunting occurs, set the deadband range to a greater value so as to suppress such hunting.

Hunting stops immediately after a deviation goes into the deadband range and the control is resumed when the deviation goes out of the deadband range.

Settable range: 0.1 to 8.0%.

Refer to the users manual of R3CON for the detailed adjustment operations.

OUTPUT OPERATION AT LOSS OF COMMUNICATION

When a communication error occurs in the middle of an output operation, the operation continues toward until reaching target position most recently set by Host device.

WIRING INSTRUCTIONS

■ SCREW TERMINAL

Torque: 0.5 N·m

■ SOLDERLESS TERMINAL

Refer to the drawing below for recommended ring tongue terminal size. Spade tongue type is also applicable. Solderless terminals with insulation sleeve do not fit.

Recommended manufacturer: Japan Solderless Terminal MFG.Co.Ltd, Nichifu Co.,ltd

Applicable wire size: 0.3 to 0.5 mm²

