

BEFORE USE

Thank you for choosing us. Before use, please check contents of the package you received as outlined below. If you have any problems or questions with the product, please contact our sales office or representatives.

■ PACKAGE INCLUDES:

- Network interface module(1)
- Neuron ID label.....(2)

■ MODEL NO.

Confirm Model No. marking on the product to be exactly what you ordered.

■ INSTRUCTION MANUAL

This manual describes necessary points of caution when you use this product, including installation, connection and basic maintenance procedures.

POINTS OF CAUTION

■ HOT SWAPPABLE MODULES

- The module can be replaced while the power is ON. Be sure to replace it when the module is not communicating with a host, as it may affect the system. Replacing multiple modules at once may greatly change line voltage levels. We highly recommend to replace them one by one.

■ POWER INPUT RATING & OPERATIONAL RANGE

- Locate the power input rating marked on the product and confirm its operational range as indicated below:
 - 100 – 120V AC rating: 85 – 132V, 47 – 66 Hz, approx. 20VA
 - 200 – 240V AC rating: 170 – 264V, 47 – 66 Hz, approx. 20VA
 - 24V DC rating: 24V ±10%, approx. 12W

■ GENERAL PRECAUTIONS

- DO NOT set the switches while the power is supplied. The switches are used only for maintenance without the power.

■ ENVIRONMENT

- Indoor use.
- When heavy dust or metal particles are present in the air, install the unit inside proper housing with sufficient ventilation.
- Do not install the unit where it is subjected to continuous vibration. Do not subject the unit to physical impact.
- Environmental temperature must be within -10 to +55°C (14 to 131°F) with relative humidity within 30 to 90% RH in order to ensure adequate life span and operation.

■ WIRING

- Do not install cables close to noise sources (relay drive cable, high frequency line, etc.).
- Do not bind these cables together with those in which noises are present. Do not install them in the same duct.

■ AND

- The unit is designed to function as soon as power is supplied, however, a warm up for 10 minutes is required for satisfying complete performance described in the data sheet.

INSTALLATION

Use the Installation Base Model R3-BS, or Model R3-BSW for free I/O address capability.

Before mounting the Network Interface Module onto the base, be sure to configure the module as explained below.

■ DATA ALLOCATION

The setting determines the data area size assigned to each I/O module mounted on the base.

■ NETWORK SLOTS ON THE BASE

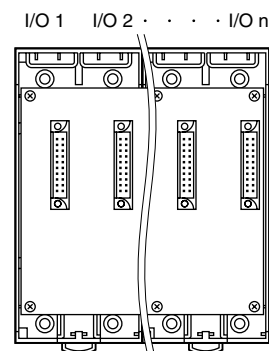

With Model R3-BS base, mount the I/O Modules from the left end (I/O 1) to the right in order that the Network Module assigns data areas from I/O 1.

Network Module(s) and Power Module are mounted basically at the right end though technically they could be mounted in any position.

With Model R3-BSW base, there is no limitation in mounting positions as I/O address can be assigned freely to each module using rotary switches equipped on the base.

COMPONENT IDENTIFICATION

FRONT VIEW

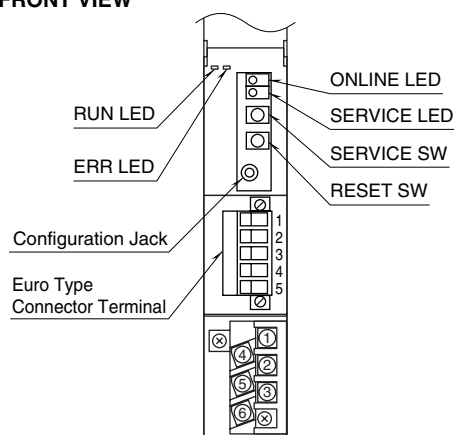

SIDE VIEW

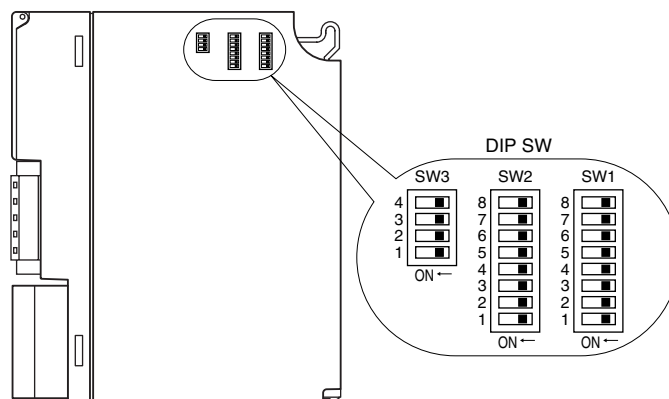

STATUS INDICATOR LED

RUN indicator: Bi-color (green/red) LED; Green ON in communications with another device on-line or changing the output data (turns off after 25 seconds of no communication)

ERR indicator: Bi-color (green/red) LED; Green ON in normal status; Green blinks when the APB file is not adequately imported; Green/Orange ON in turn in an abnormality.

ONLINE indicator: Red LED

ON: Off-line or no network information (decommissioned)

Blinking in approx. 0.5 Hz: On-line (ready to communicate network variables)

Blinking in approx. 5 Hz for 12 sec.: Wink message received

SERVICE indicator: Green LED

OFF: Normal operations

Blinking in approx. 0.5 Hz: No network information

ON: Internal program error

SERVICE SW

Used to identify the node in LONWORKS network configuration.

RESET SW

Used to reset the Neuron Chip. Press the switch to reset. Control functions are halted while completing resetting and restarting. Confirm no danger before conducting resetting.

SIDE DIP SW

(*) Factory setting.

• Data Allocation: SW1, SW2

Data Allocation Type* must be assigned to each I/O module position to specify how many data areas (four types) are to be occupied by each.

Two bits from SW1 and SW2 are assigned to each position, and data areas can be specified from the module No. 1 through 8. Setting for No. 9 and later modules is identical to No. 8.

SW ASSIGNMENT		MODULE NO.
SW1-1	SW1-2	1
SW1-3	SW1-4	2
SW1-5	SW1-6	3
SW1-7	SW1-8	4
SW2-1	SW2-2	5
SW2-3	SW2-4	6
SW2-5	SW2-6	7
SW2-7	SW2-8	8
SW SETTING		DATA ALLOCATION
OFF	OFF	1
ON	OFF	4
OFF	ON	8
ON	ON	16

* Refer to the specifications of the related series for the Data Allocation Type of I/O modules.

• Input Error Data: SW3-2

Hold: When the communication from an input module is lost due to the input module error, the network module holds the signal and stands by until the communication recovers.

Set to '0': When the communication from an input module is lost due to the input module error, the network module outputs '0.'

SW	INPUT ERROR DATA	
	HOLD (*)	SET '0'
SW3-2	OFF	ON

Note: Be sure to set unused SW3-1, 3-3 and 3-4 to OFF.

PC CONFIGURATOR

With configurator software, settings shown below are available.
Refer to the software manual of R3CON for detailed operation.

NETWORK MODULE SETTING

PARAMETER	AVAILABLE RANGE	DEFAULT SETTING
Time (no communication time)	3.0 – 3200.0 (sec.)	3.0 (sec.)

TERMINAL CONNECTIONS

Connect the unit as in the diagram below.

EXTERNAL DIMENSIONS unit: mm (inch)

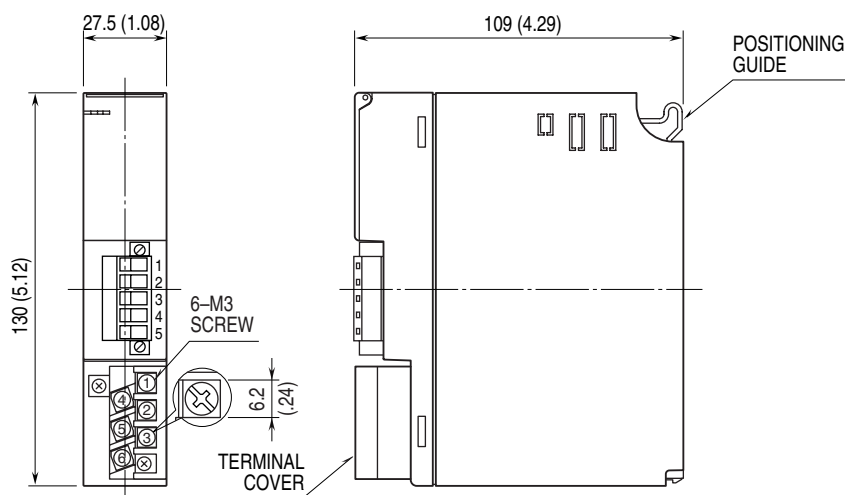

CONNECTION DIAGRAM

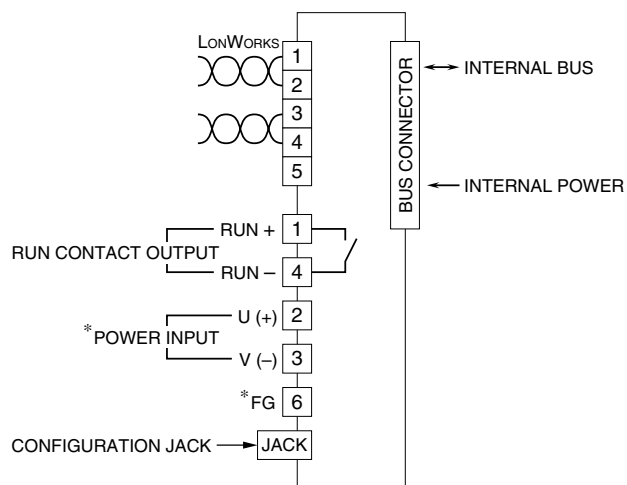

* Not provided with 'No Power Supply' type module.
Caution: FG terminal is NOT a protective conductor terminal.

WIRING INSTRUCTIONS

M3 SCREW TERMINAL (power input, RUN contact output)

Torque: 0.5 N·m

SOLDERLESS TERMINAL

Refer to the drawing below for recommended ring tongue terminal size. Spade tongue type is also applicable. Solderless terminals with insulation sleeve do not fit.

Recommended manufacturer: Japan Solderless Terminal MFG.Co.Ltd, Nichifu Co.,ltd

Applicable wire size: 0.75 to 1.25 mm²

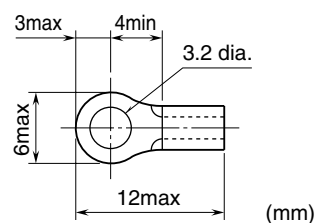

EURO TYPE CONNECTOR TERMINAL (LonWORKS)

Applicable wire size: 0.2 to 2.5 mm² (AWG24 to 12)

Stripped length: 7 mm

COMMUNICATION CABLE CONNECTIONS

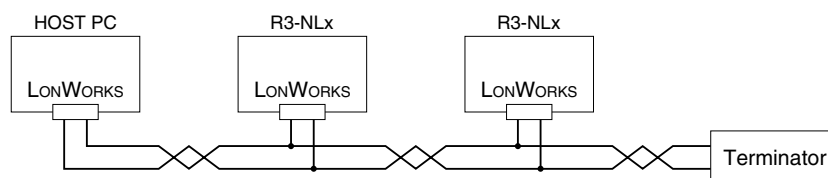

I/O COMBINATIONS

A dedicated Device File for each I/O device depending upon I/O combinations is required to set up the R3-NL2 using an integration tool such as LonMaker.

On-line download is available for Device Image files at our web site.

Functional Blocks usable for respective files are not identical to all. Refer to the table below.

ANALOG INPUT / OUTPUT

NO. of DATA		NETWORK VARIABLE	DEVICE IMAGE	USABLE FUNCTIONAL BLOCKS
INPUT	OUTPUT			
56	0	SNVT_lev_percent	R3NL2_LVI56_103.XIF R3NL2_LVI56_103.APB	NodeObject NL2LVIn
0	56	SNVT_lev_percent	R3NL2_LVO56_103.XIF R3NL2_LVO56_103.APB	NodeObject NL2LVOOut
32	24	SNVT_lev_percent	R3NL2_LVI32O24_104.XIF R3NL2_LVI32O24_104.APB	NodeObject NL2LVIO

TEMPERATURE INPUT (°C)

NO. of DATA		NETWORK VARIABLE	DEVICE IMAGE	USABLE FUNCTIONAL BLOCKS
INPUT	OUTPUT			
56	0	SNVT_temp	R3NL2_TI56_103.XIF R3NL2_TI56_103.APB	NodeObject NL2TIn
56	0	SNVT_temp_p	R3NL2_TPI56_103.XIF R3NL2_TPI56_103.APB	NodeObject NL2TPIn

DISCRETE INPUT / OUTPUT

NO. of DATA		NETWORK VARIABLE	DEVICE IMAGE	USABLE FUNCTIONAL BLOCKS
INPUT	OUTPUT			
56	0	SNVT_switch	R3NL2_SWI56_103.XIF R3NL2_SWI56_103.APB	NodeObject NL2SWIn
0	56	SNVT_switch	R3NL2_SWO56_103.XIF R3NL2_SWO56_103.APB	NodeObject NL2SWOut
32	24	SNVT_switch	R3NL2_SWI32O24_103.XIF R3NL2_SWI32O24_103.APB	NodeObject NL2SWIO

TOTALIZED PULSE INPUT / OUTPUT

NO. of DATA		NETWORK VARIABLE	DEVICE IMAGE	USABLE FUNCTIONAL BLOCKS
INPUT	OUTPUT			
56	0	SNVT_count	R3NL2_CI56_103.XIF R3NL2_CI56_103.APB	NodeObject NL2CIn
0	56	SNVT_count	R3NL2_CO56_104.XIF R3NL2_CO56_104.APB	NodeObject NL2COut
32	24	SNVT_count	R3NL2_CI32O24_103.XIF R3NL2_CI32O24_103.APB	NodeObject NL2CInOut

TOTALIZED PULSE INPUT / DISCRETE I/O

NO. of DATA			NETWORK VARIABLE	DEVICE IMAGE	USABLE FUNCTIONAL BLOCKS
TOTAL.PULSE	DISCRETE				
INPUT	INPUT	OUTPUT			
16	16	16	SNVT_count SNVT_switch	R3NL2_CI16SWI16SWO16_103.XIF R3NL2_CI16SWI16SWO16_103.APB	NodeObject NL2CISWIO

XIF File: Device Interface File (external interface)

APB File: Downloadable Application Image File (program for Neuron Chip)

FUNCTIONAL BLOCKS

■ NODE OBJECT

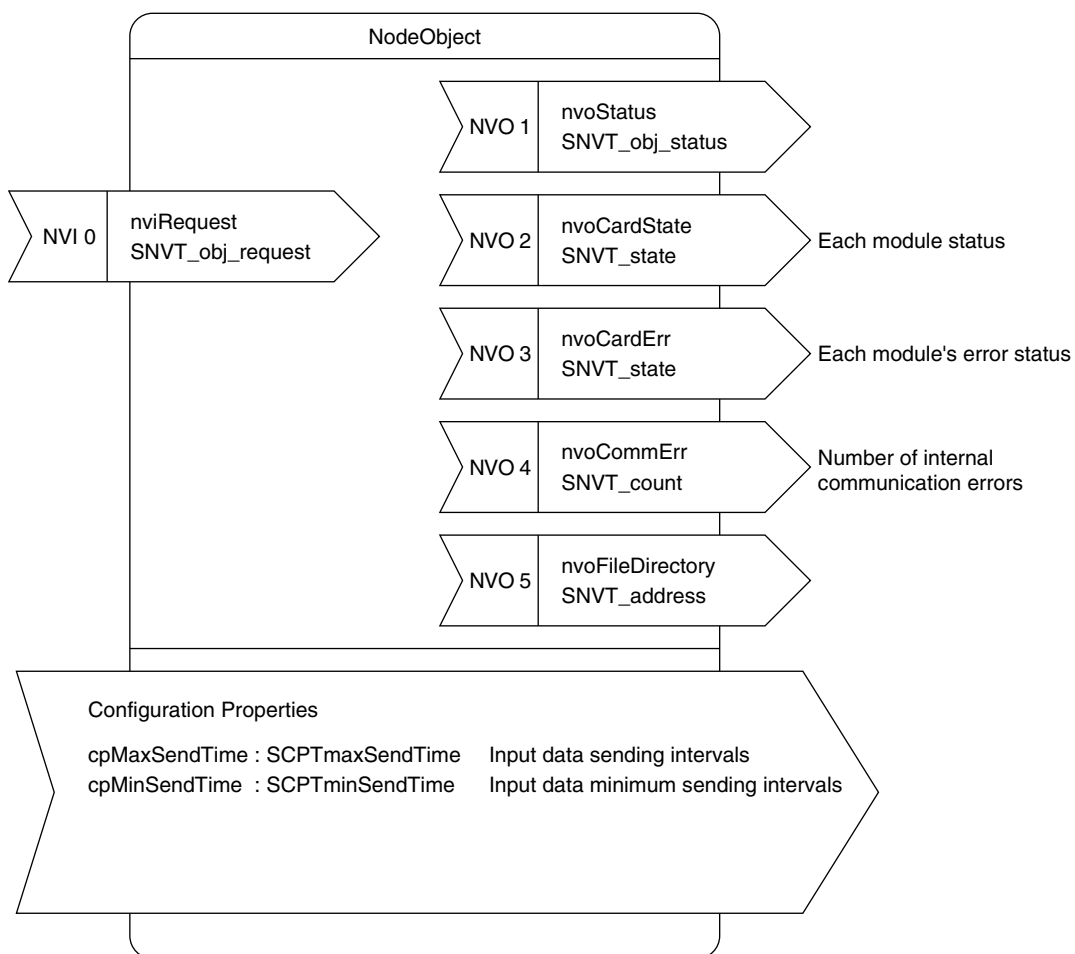

■ ANALOG I/O FUNCTIONAL BLOCKS

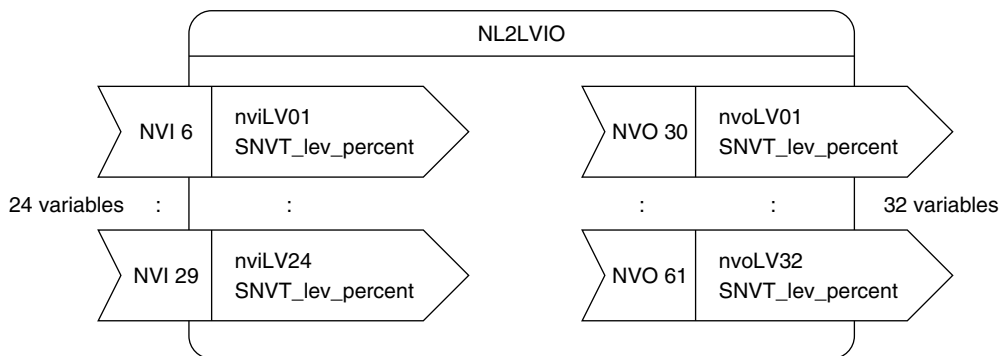
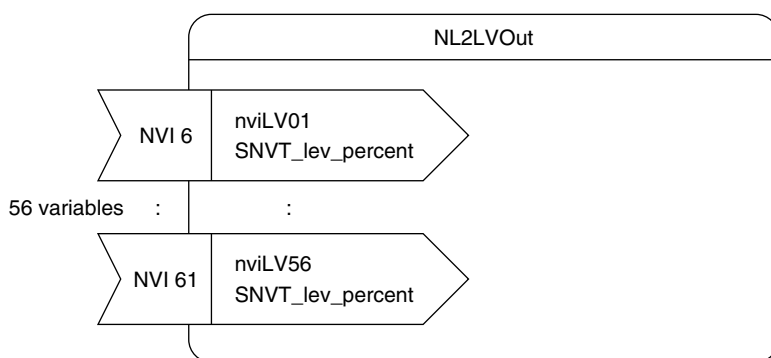
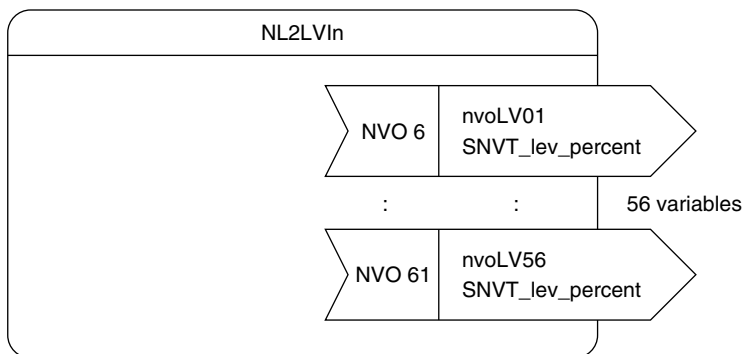

■ TEMPERATURE INPUT FUNCTIONAL BLOCKS

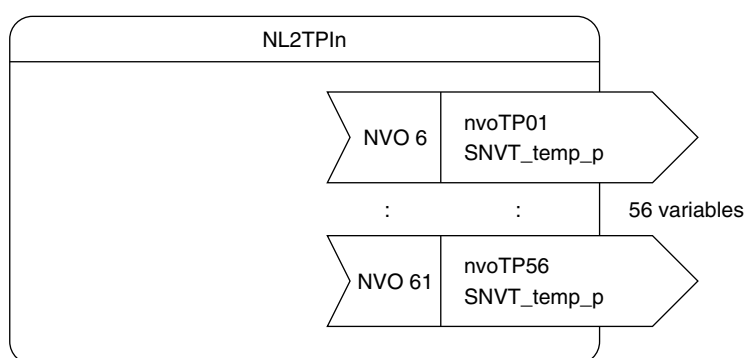
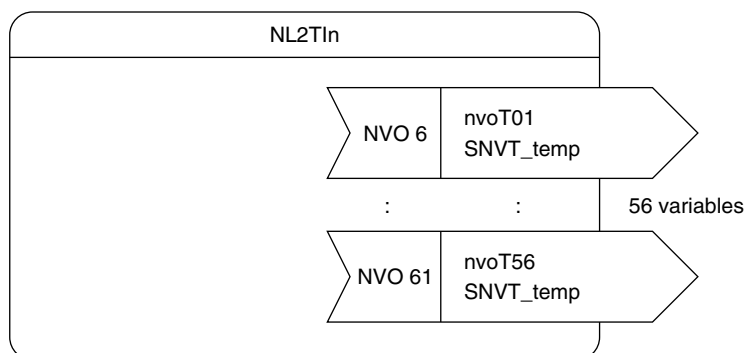

■ DISCRETE I/O FUNCTIONAL BLOCKS

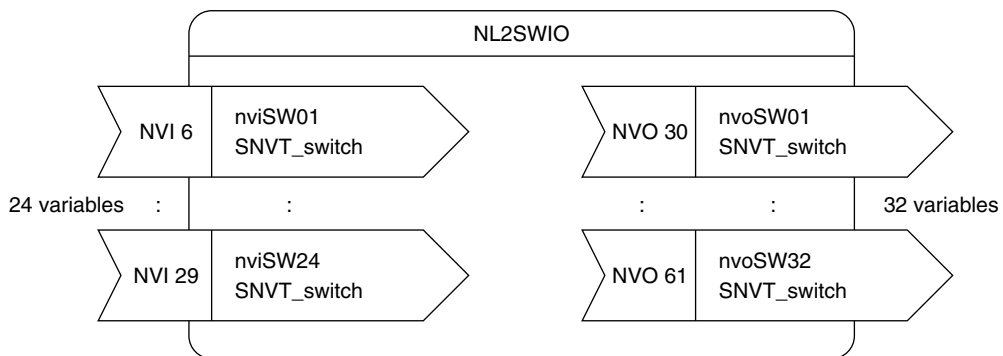
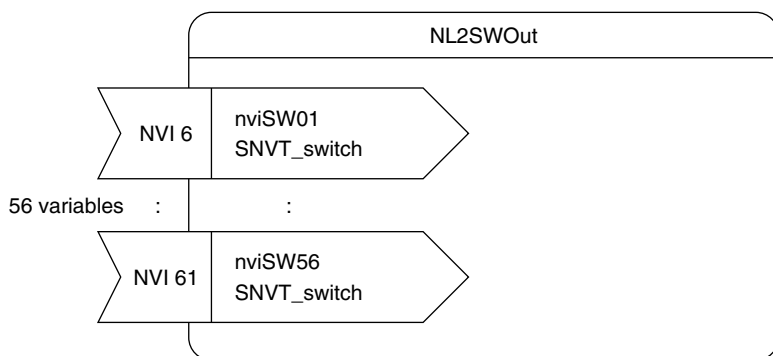
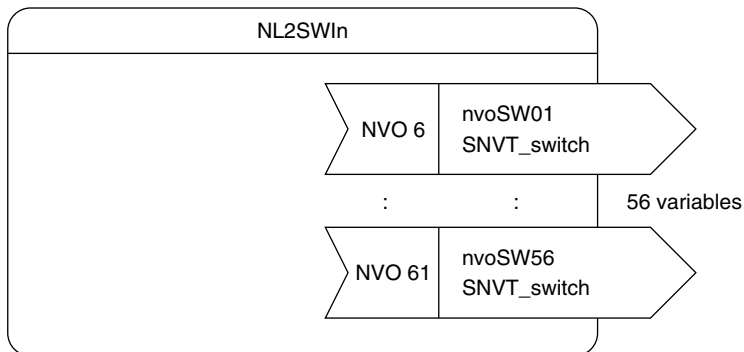

■ TOTALIZED PULSE I/O FUNCTIONAL BLOCKS

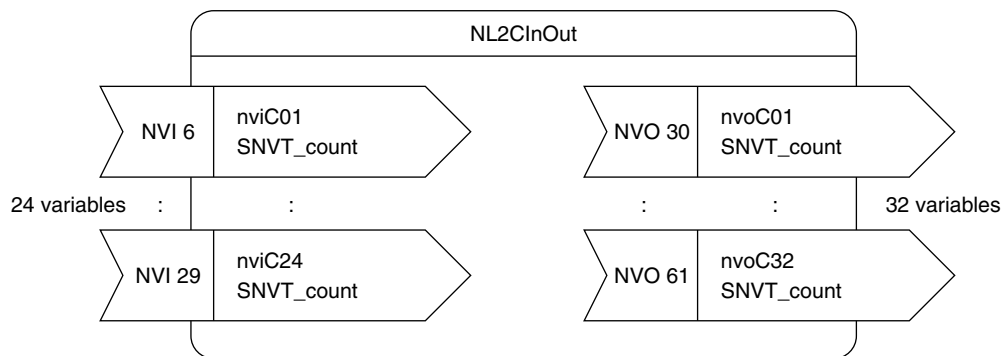
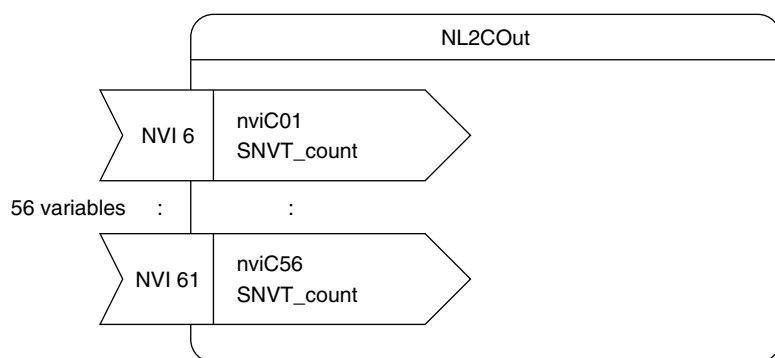
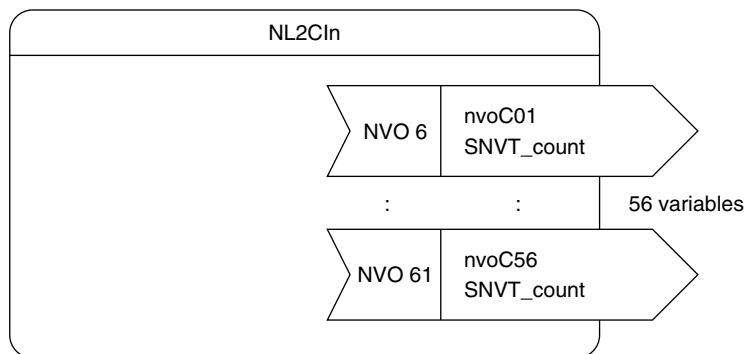

■ TOTALIZED PULSE INPUT / DISCRETE I/O FUNCTIONAL BLOCKS

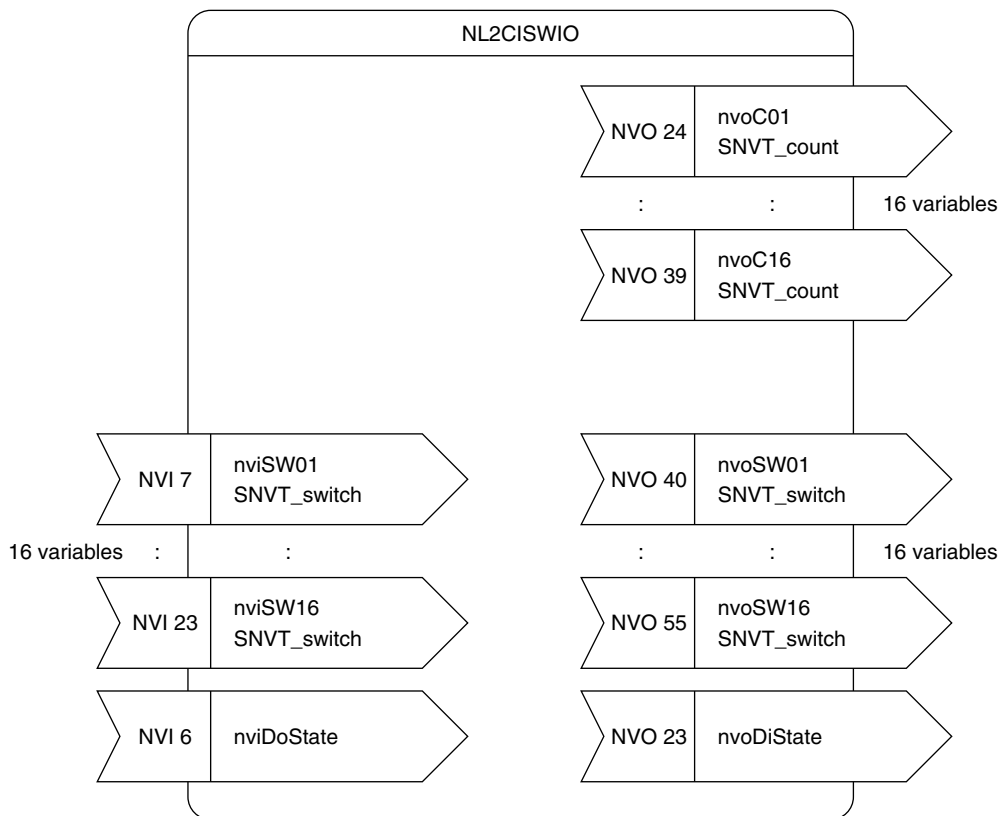

■ NodeObject FUNCTIONAL BLOCKS

NETWORK VARIABLE	TYPE {Range} {Default}	EXPLANATIONS
nviRequest	SNVT_obj_request {Usable RQ RQ_NORMAL RQ_REPORT_MASK RQ_UPDATE_STATUS}	Used for integration tools such as LonMaker.
nvoStatus		Used for integration tools such as LonMaker. <ul style="list-style-type: none"> • nviRequest RQ_NORMAL 0 is set at nvoStatus. • nviRequest RQ_REPORT_MASK report_mask bit is set at nvoStatus. • nviRequest RQ_UPDATE_STATUS 0 is set at nvoStatus. • 1 is set at invalid_id when any value other than the above three types is set at nviRequest.
nvoFileDirectory	SNVT_address	Used for integration tools such as LonMaker.
nvoCommErr	SNVT_count {0 through 65535} {0}	Counted in internal communication errors. Reset to 0 after the count has reached 65535.
nvoCardStatus	SNVT_state {0 or 1} {0,0,0,0,0,0,0,0,0,0,0,0,0,0,0,0}	Indicates that I/O modules are mounted in each slot. Bit 0 through bit 15 are applied for slot 1 through 16. 0: Not mounted 1: Mounted
nvoCardErr	SNVT_state {0 or 1} {0,0,0,0,0,0,0,0,0,0,0,0,0,0,0,0}	Indicates error status for each module/slot. Bit 0 through bit 15 are applied for slot 1 through 16. 0: Normal 1: Error
CONFIGURATION PROPERTY	TYPE {Range} {Default}	EXPLANATIONS
cpMaxSendTime	SCPTmaxSendTime {0.0 through 6553.4} {5.0}	Sending time intervals of input network variables. (Power restarting required) Network variables are sent out in this time intervals even when there is no change in input signals. Default setting 0.0 with the R3NL2_LVI32O24_104.XIF (No sending out unless a change is detected.)
cpMinSendTime	SCPTminSendTime {0.0 through 6553.4} {0.1}	Minimum sending time intervals of input network variables. (Power restarting required) This minimum time intervals is maintained even when the input signals changes faster than it. Default setting 1.0 with the R3NL2_LVI32O24_104.XIF

■ OTHER FUNCTIONAL BLOCKS (NL2LVIn, NL2LVOut, NL2LVIO, NL2TIn, NL2TPIn, NL2SWIn, NL2SWOut, NL2SWIO, NL2CIn, NL2COut, NL2CInOut, NL2CISWIO)

NETWORK VARIABLE	TYPE {Range} {Default}	EXPLANATIONS
nvoLV01 thr. nvoLV56	SNVT_lev_percent {-163.840 through 163.830} {0.0}	Data for analog input modules.
nviLV01 thr. nviLV56	SNVT_lev_percent {-163.840 through 163.830} {0.0}	Data for analog output modules.
nvoT01 thr. nvoT56	SNVT_temp {-274.0 through 3002.7} {0.0}	Data for temperature input modules.
nvoTP01 thr. nvoTP56	SNVT_temp_p {-273.17 through 327.66} {0.0}	Data for temperature input modules.
nvoSW01 thr. nvoSW56	SNVT_switch {0.0,0} or {100.0,1} {0.0,0}	ON/OFF data for discrete input modules. OFF : {0.0,0} ON : {100.0,1}
nviSW01 thr. nviSW56	SNVT_switch {0.0,0} or {100.0,1} {0.0,0}	ON/OFF data for discrete output modules. OFF : {0.0,0} ON : {100.0,1}
nvoC01 thr. nvoC56	SNVT_count {0 through 65535} {0}	Data for totalized pulse input modules.
nviC01 thr. nviC56	SNVT_count {0 through 65535} {0}	Data for totalized pulse output modules.
nviDoState	SNVT_state	For factory adjustment. Do not use.
nvoDiState	SNVT_state	For factory adjustment. Do not use.

TRANSMISSION DATA ASSIGNMENTS

■ ANALOG INPUT / OUTPUT

The DIP SW located at the side of the module specifies each I/O module's data allocation (occupied data area).

[Example 1]

Seven (7) of 8-point analog input module: Use APB: R3NL2_LVI56.

Position	Module Type	Data Area	Network Variable
Module 1	R3-SV8S	8	nvoLV01 through nvoLV08
Module 2	R3-SV8S	8	nvoLV09 through nvoLV16
Module 3	R3-SV8S	8	nvoLV17 through nvoLV24
Module 4	R3-SV8S	8	nvoLV25 through nvoLV32
Module 5	R3-SV8S	8	nvoLV33 through nvoLV40
Module 6	R3-SV8S	8	nvoLV41 through nvoLV48
Module 7	R3-SV8S	8	nvoLV49 through nvoLV56
Module 8	R3-NL2-N		
Module 9	R3-PS3-R		

The same principle is applied to Analog Output (R3NL2_LVO56) or Temperature Input (R3NL2_TI56, R3NL2_TPI56).

■ DISCRETE INPUT / OUTPUT

One (1) data area can handle 16 points of discrete signals.

[Example 2]

Four (4) of 16-point discrete input module: Use APB: R3NL2_SWI56.

Position	Module Type	Data Area	Network Variable
Module 1	R3-DA16S	1	nvoSW01 through nvoSW16
Module 2	R3-DA16S	1	nvoSW17 through nvoSW32
Module 3	R3-DA16S	1	nvoSW33 through nvoSW48
Module 4	R3-DA16S	1	nvoSW49 through nvoSW56
Module 5	R3-NL2-N		
Module 6	R3-PS1-R		

Channels 9 through 16 of the Module 4 are not transmitted.

■ MIXED I/O

Network Variables for the input channels are assigned first, and then those for the output channels are assigned to the next module position.

[Example 3]

Four (4) of 8-point analog input module and three (3) of 8-point analog output: Use APB: R3NL2_LVI32O24.

Position	Module Type	Data Area	Network Variable
Module 1	R3-SV8S	8	nvoLV01 through nvoLV08
Module 2	R3-SV8S	8	nvoLV09 through nvoLV16
Module 3	R3-SV8S	8	nvoLV17 through nvoLV24
Module 4	R3-SV8S	8	nvoLV25 through nvoLV32
Module 5	R3-YV8S	8	nviLV01 through nviLV08
Module 6	R3-YV8S	8	nviLV09 through nviLV16
Module 7	R3-YV8S	8	nviLV17 through nviLV24
Module 8	R3-NL2-N		
Module 9	R3-PS3-R		

■ TOTALIZED PULSE INPUT / DISCRETE I/O

Network Variables for the discrete input channels are assigned first, and then those for the totalized pulse input channels are assigned to the next module position. Finally those for the discrete output channels are assigned to the following module position. The I/O modules must be assigned as in the flowing example. Adequate operation is not guaranteed in any other configuration.

[Example 4]

One (1) of 16-point totalized pulse input module, one (1) of 16-point discrete input module, and one (1) of 16-point discrete output: Use APB: R3NL2_CII16SWI16SWO16.

Position	Module Type	Data Area	Network Variable
Module 1	R3-DA16S	1	nvoSW01 through nvoSW16
Module 2	R3-PA16S	16	nvoC01 through nvoC16
Module 3	R3-DC16S	1	nviSW01 through nviSW16
Module 4	R3-NL2-N		
Module 5	R3-PS1-R		