

MODBUS INTERFACE MODULE
(for 115.2 kbps)

MODEL **R3-NM4**

BEFORE USE

Thank you for choosing us. Before use, please check contents of the package you received as outlined below. If you have any problems or questions with the product, please contact our sales office or representatives.

■ PACKAGE INCLUDES:

- Network interface module(1)
- Terminating resistor (110 Ω, 0.25 W).....(1)

■ MODEL NO.

Confirm that the model number described on the product is exactly what you ordered.

■ INSTRUCTION MANUAL

This manual describes necessary points of caution when you use this product, including installation, connection and basic maintenance procedures.

POINTS OF CAUTION

■ HOT SWAPPABLE MODULES

- The module can be replaced while the power is ON. Be sure to replace it when the module is not communicating with a host, as it may affect the system. Replacing multiple modules at once may greatly change line voltage levels. We highly recommend to replace them one by one.

■ POWER INPUT RATING & OPERATIONAL RANGE

- Locate the power input rating marked on the product and confirm its operational range as indicated below:
 - 100 – 240V AC rating: 85 – 264V, 47 – 66 Hz
 - approx. 20VA at 100V AC
 - approx. 28VA at 200V AC
 - approx. 30VA at 240V AC
 - 24V DC rating: 24V ±10%, approx. 12W

■ GENERAL PRECAUTIONS

- DO NOT set the switches on the module while the power is supplied. The switches are used only for maintenance without the power.

■ ENVIRONMENT

- Indoor use.
- When heavy dust or metal particles are present in the air, install the unit inside proper housing with sufficient ventilation.
- Do not install the unit where it is subjected to continuous vibration. Do not subject the unit to physical impact.
- Environmental temperature must be within -10 to +55°C (14 to 131°F) with relative humidity within 30 to 90% RH in order to ensure adequate life span and operation.

■ WIRING

- Do not install cables close to noise sources (relay drive cable, high frequency line, etc.).
- Do not bind these cables together with those in which noises are present. Do not install them in the same duct.

■ AND

- The unit is designed to function as soon as power is supplied, however, a warm up for 10 minutes is required for satisfying complete performance described in the data sheet.

INSTALLATION

Use the Installation Base Model R3-BS, or Model R3-BSW for free I/O address capability.

Before mounting the Network Interface Module onto the Base, be sure to configure the module as explained below.

■ DATA ALLOCATION

The setting determines the data area size assigned to each I/O module mounted on the base. The data sent/received via Modbus is mapped according to this setting. See “COMPONENT IDENTIFICATION” and “MODBUS I/O ASSIGNMENTS”.

■ NODE ADDRESS & BAUD RATE, ETC.

See “COMPONENT IDENTIFICATION”.

■ NETWORK SLOTS ON THE BASE

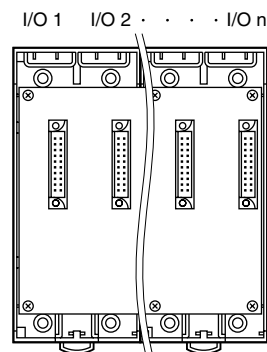

With Model R3-BS base, mount the I/O Modules from the left end (I/O 1) to the right in order that the Network Module assigns data areas from I/O 1.

Network Module(s) and Power Module are mounted basically at the right end though technically they could be mounted in any position.

With Model R3-BSW base, there is no limitation in mounting positions as I/O address can be assigned freely to each module using rotary switches equipped on the base.

COMPONENT IDENTIFICATION

FRONT VIEW

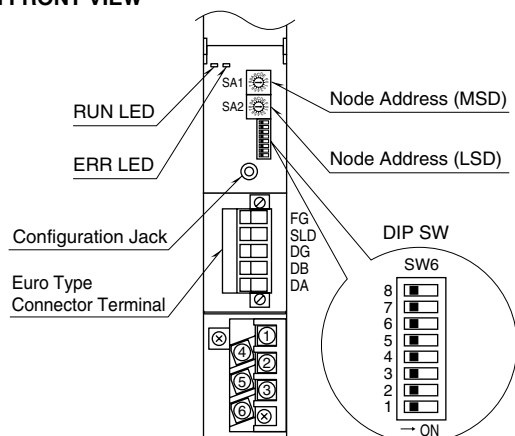

SIDE VIEW

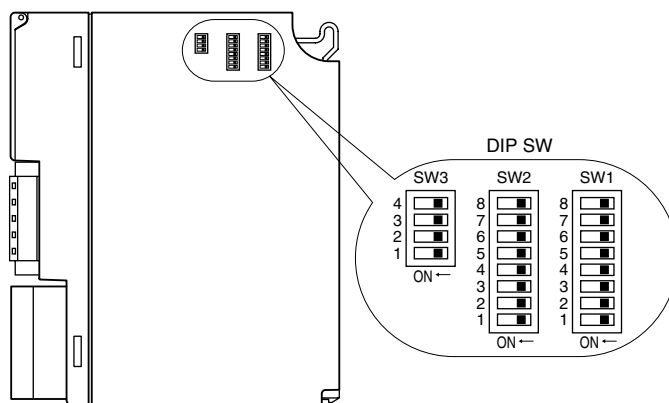

FRONT ROTARY SW

Node Address: SA1, SA2

Set the module's node address in hexadecimal with SA1 and SA2. (Setpoint adjustment: 01 – F7)

FRONT DIP SW

(*) Factory setting

Baud Rate: SW6-1, 6-2, 6-3, 6-4

SW	BAUD RATE (bps)											
	115.2 k	57.6 k	38.4 k	28.8 k	19.2 k	14.4 k	9600	4800	2400	1200	600	300
SW6-1	OFF (*)	ON	OFF	ON	OFF	ON	OFF	ON	OFF	ON	OFF	ON
SW6-2	OFF (*)	OFF	ON	ON	OFF	OFF	ON	ON	OFF	OFF	ON	ON
SW6-3	OFF (*)	OFF	OFF	OFF	ON	ON	ON	ON	OFF	OFF	OFF	OFF
SW6-4	OFF (*)	OFF	OFF	OFF	OFF	OFF	OFF	OFF	ON	ON	ON	ON

Parity: SW6-5, 6-6*1

SW	PARITY			
	NONE (*)	ODD	EVEN	N/A
SW6-5	OFF	ON	OFF	ON
SW6-6	OFF	OFF	ON	ON

Data Mode: SW6-7*1

SW	DATA MODE	
	RTU (Binary)(*)	ASCII
SW6-7	OFF	ON

*1. Bit assignment according to Parity and Data Mode setting.

MODE	START	DATA	PARITY	STOP
RTU	1	8	1	1
	1	8	None	2
ASCII	1	7	1	1
	1	7	None	2

Note: Be sure to set unused SW6-8 to OFF.

■ SIDE DIP SW

(*) Factory setting

• Data Allocation: SW1, SW2

Data Allocation Type*2 must be assigned to each I/O module slot position to specify how many data areas (four types) are to be occupied by each.

Two bits from SW1 and SW2 are assigned to each position, and data areas can be specified from the slot No. 1 through 8. Setting for No. 9 and later slots is identical to No. 8.

SW ASSIGNMENT		SLOT
SW1-1	SW1-2	1
SW1-3	SW1-4	2
SW1-5	SW1-6	3
SW1-7	SW1-8	4
SW2-1	SW2-2	5
SW2-3	SW2-4	6
SW2-5	SW2-6	7
SW2-7	SW2-8	8

SW SETTING		DATA ALLOCATION
OFF	OFF	1
ON	OFF	4
OFF	ON	8
ON	ON	16

*2. Refer to the specifications of the related series for the Data Allocation Type of I/O modules.

• Dual Communication: SW3-1

When two network modules are mounted, one must be 'Main' (OFF) network and the other must be 'Sub' (ON) network. For single communication, the network module must always be set to 'Main' (OFF).

SW	DUAL COMMUNICATION	
	MAIN (*)	SUB
SW3-1	OFF	ON

• Input Error Data: SW3-2

Hold: When the communication from an input module is lost due to the input module error, the network module holds the signal and stands by until the communication recovers.

Set to '0': When the communication from an input module is lost due to the input module error, the network module outputs '0.'

SW	INPUT ERROR DATA	
	HOLD (*)	SET '0'
SW3-2	OFF	ON

• Main/Sub Switching Control: SW3-3

The host PC or PLC can choose whether 'Main' or 'Sub' bus is used when the switching control is set to 'Host.'

In 'Normal' mode, 'Main' bus is normally used, while 'Sub' bus is when the main communication has failed.

Be sure to match this control mode for both network modules in dual communication mode.

SW	MAIN/SUB SWITCHING CONTROL	
	NORMAL (*)	HOST
SW3-3	OFF	ON

Note: Set SW3-3 to OFF for use in single communication mode.

• LED Function: SW3-4

Functions assigned to the front RUN and ERR LEDs can be selected.

SW3-4	LED FUNCTION	
	RUN	ERR
OFF (*)	Green when normal	Green when abnormal
ON	Red when receiving	Red when transmitting

PC CONFIGURATOR

The following parameter items can be set with PC Configurator Software (model: R3CON). Refer to the users manual for the R3CON for detailed operation of the software program.

■ NETWORK MODULE SETTING

PARAMETER	SETTING RANGE	DEFAULT SETTING
Time (no communication time)	0.2 – 3200.0 (sec.)	3.0 (sec.)

TERMINAL CONNECTIONS

Connect the unit as in the diagram below.

EXTERNAL DIMENSIONS unit: mm (inch)

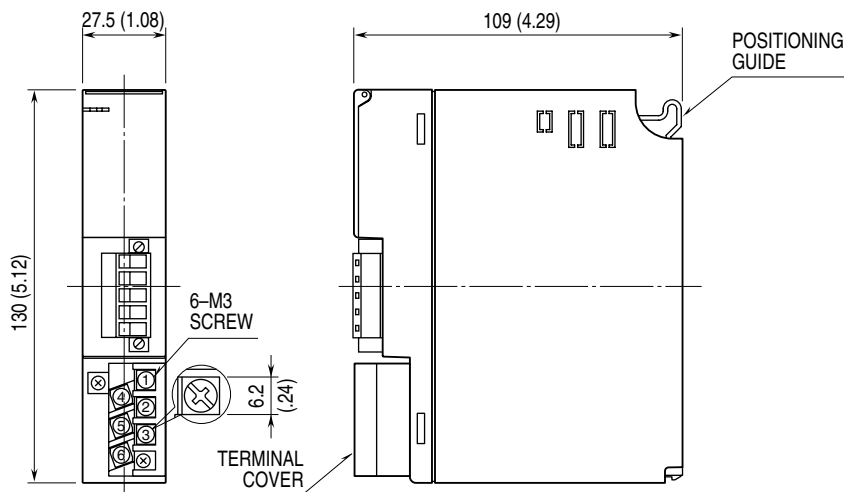

CONNECTION DIAGRAM

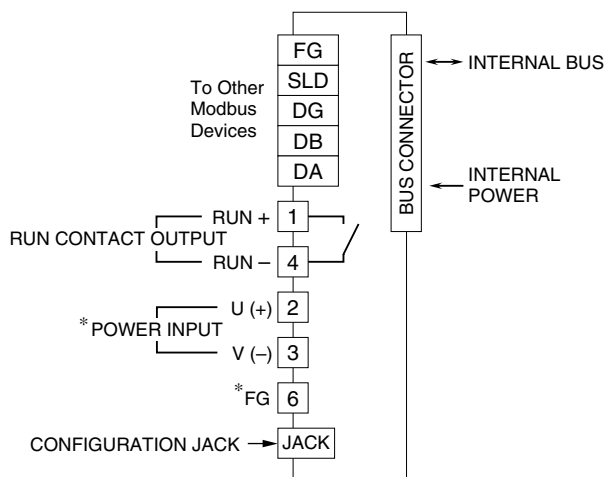

*Not provided with 'No Power Supply' type module.
Caution: FG terminal is NOT a protective conductor terminal.

WIRING INSTRUCTIONS

■ M3 SCREW TERMINAL (power input, RUN contact output)
Torque: 0.5 N·m

■ SOLDERLESS TERMINAL

Refer to the drawing below for recommended ring tongue terminal size. Spade tongue type is also applicable. Solderless terminals with insulation sleeve do not fit.

Recommended manufacturer: Japan Solderless Terminal MFG.Co.Ltd, Nichifu Co.,ltd

Applicable wire size: 0.75 to 1.25 mm²

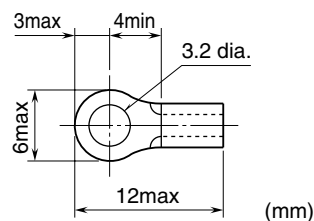

■ EURO TYPE CONNECTOR TERMINAL (Modbus)

Applicable wire size: 0.2 to 2.5 mm² (AWG24 to 12)

Stripped length: 7 mm

COMMUNICATION CABLE CONNECTIONS

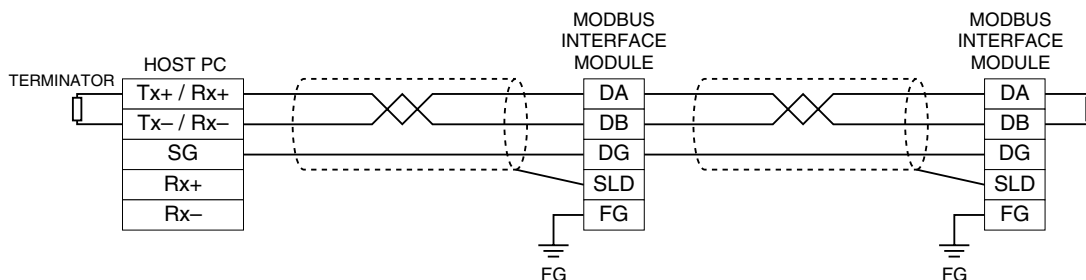

MODBUS FUNCTION CODES & SUPPORTED CODES

■ Data and Control Functions

CODE	NAME		
01	Read Coil Status	X	Digital output from the slave
02	Read Input Status	X	Status of digital inputs to the slave
03	Read Holding Registers	X	General purpose register within the slave
04	Read Input Registers	X	Collected data from the field by the slave
05	Force Single Coil	X	Digital output from the slave
06	Preset Single Register	X	General purpose register within the slave
07	Read Exception Status		
08	Diagnostics	X	
09	Program 484		
10	Poll 484		
11	Fetch Comm. Event Counter	X	Fetch a status word and an event counter
12	Fetch Comm. Event Log	X	A status word, an event counter, a message count and a field of event bytes
13	Program Controller		
14	Poll Controller		
15	Force Multiple Coils	X	Digital output from the slave
16	Preset Multiple Registers	X	General purpose register within the slave
17	Report Slave ID	X	Slave type / 'RUN' status
18	Program 884/M84		
19	Reset Comm. Link		
20	Read General Reference		
21	Write General Reference		
22	Mask Write 4X Register		
23	Read/Write 4X Register		
24	Read FIFO Queue		

■ Exception Codes

CODE	NAME		
01	Illegal Function	X	Function code is not allowable for the slave
02	Illegal Data Address	X	Address is not available within the slave
03	Illegal Data Value	X	Data is not valid for the function
04	Slave Device Failure		
05	Acknowledge		
06	Slave Device Busy		
07	Negative Acknowledge		
08	Memory Parity Error		

■ Diagnostic Subfunctions

CODE	NAME		
00	Return Query Data	X	Loop back test
01	Restart Comm. Option		Reset the slave and clear all counters
02	Return Diagnostic Register		Contents of the diagnostic data (2 bytes)
03	Change ASCII Input Delimiter		Delimiter character of ASCII message
04	Force Listen Only Mode		Force the slave into Listen Only Mode

MODBUS I/O ASSIGNMENTS

	ADDRESS	DATA FORMAT	NAME
Coil (0X)	1 – 1024		Digital Output (discrete output)
	1025		Main / Sub Switching Command (valid only with SW3-3 set to ON)
Inputs (1X)	1 – 1024		Digital Input (discrete input)
	1025 – 1040		Module Status
	1041 – 1056		Error Status
	1057 – 1072		Data Error Status
Input Registers (3X)	1 – 256	I	Analog Input
	257 – 768	F	Analog Input
Holding Registers (4X)	1 – 256	I	Analog Output
	257 – 768	F	Analog Output

I: Integer, 0 – 10000 (0 – 100%)

F: Floating (32-bit data cannot be accessed using floating addresses.)

Note: DO NOT access addresses other than mentioned above. Such access may cause problems such as inadequate operation.

- Module Status indicates whether individual I/O modules are mounted or not. The bit corresponding to the mounted slot turns to “1,” and the unmounted slot to “0.”
- Error Status indicates error status for each module as described below. The bit corresponding to such module turns to “1.”
R3-TSx, R3-RSx, R3-US4: Input burnout
R3-DA16A: Power input in error or disconnected
R3-YSx: Output current error (e.g. load unconnected)
R3-PC16A: External power supply in error or disconnected
- Data Error Status indicates overrange (R3-US4: out of -10% to +110%; the other types: out of -15% to +115%) status for each module. The bit corresponding to such module turns to “1.”
- Main / Sub Switching Commands given to the network modules result as follows:

'MAIN' MODULE	'SUB' MODULE	OUTPUT MODE
1	0	Main bus is used; Red light turns on at RUN LED of the I/O modules.
0	1	Sub bus is used; Green light turns on at RUN LED of the I/O modules.
1	1	Main bus is used; Amber light turns on at RUN LED of the I/O modules.
0	0	Output is invalid; RUN LED of the I/O modules turns off.

TRANSMISSION DATA ASSIGNMENTS

DIP SW located at the side of the module specifies each I/O module's data allocation (occupied data area).

For example, when the data areas are assigned as shown below:

Module 1	4
Module 2	4
Module 3	4
Module 4	1
Module 5	1
Module 6	1
Module 7	1

Then the I/O data are assigned as in the table below:

	ADDRESS	POSITION		ADDRESS	POSITION
Input Registers (3X)	1 – 4, 257 – 264	Slot 1	Coil (0X)	1 – 64	Slot 1
Holding Registers (4X)	5 – 8, 265 – 272	Slot 2	Inputs (1X)	65 – 128	Slot 2
	9 – 12, 273 – 280	Slot 3		129 – 192	Slot 3
	13, 281 – 282	Slot 4		193 – 208	Slot 4
	14, 283 – 284	Slot 5		209 – 224	Slot 5
	15, 285 – 286	Slot 6		225 – 240	Slot 6
	16, 287 – 288	Slot 7		241 – 256	Slot 7

For Coil (0X) and Inputs (1X), addresses 16 times assigned data areas (Data Allocation Type) are allotted with the Data Allocation Type '1' and '4.' With '8' and '16,' 64 (4 × 16) are automatically allotted.

MODULE STATUS, ERROR STATUS, DATA ERROR STATUS

Shows each module's availability and error status.

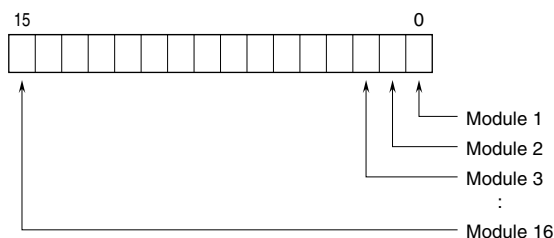

I/O DATA DESCRIPTIONS

The data allocations for typical I/O modules are shown below.
Refer to the manual for each module for detailed data allocations.

■ ANALOG DATA (16-bit data, models: R3-SV4, YV4, DS4, YS4 and US4, etc.)

16-bit binary data.

Basically, 0 to 100% of the selected I/O range is converted into 0 to 10000 (binary).

-15 to 0 % is a negative range represented in 2's complement.

In case of R3-US4, -10 to 0% is a negative range represented in 2's complement.



■ TEMPERATURE DATA (16-bit data, models: R3-RS4, TS4 and US4, etc.)

16-bit binary data.

With °C temperature unit, raw data is multiplied by 10. For example, 25.5°C is converted into 255.

With °F temperature unit, the integer section of raw data is directly converted into the data. For example, 135.4°F is converted into 135.

Minus temperature is converted into negative values, represented in 2's complements.



■ ANALOG DATA (16-bit data, models: R3-CT4A, CT4B, etc.)

16-bit binary data.

Integer obtained by multiplying unit value (A) by 100.

In case of CLSE-R5, integer obtained by multiplying unit value (A) by 1000.



■ ACCUMULATED COUNT DATA (32-bit data, models: R3-PA2, PA4A, WT1, WT4, etc.)

32-bit binary data is used for accumulated counts and encoder positions.

Lower 16 bits are allocated from the lowest address to higher ones, higher 16 bits in turn.

32-bit data cannot be accessed using floating addresses.



■ BCD DATA (32-bit data, models: R3-BA32A, BC32A, etc.)

32-bit binary data is used for BCD.

Lower 16 bits are allocated from the lowest address to higher ones, higher 16 bits in turn.

32-bit data cannot be accessed using floating addresses.



■ DISCRETE DATA (models: R3-DA16 and DC16, etc.)

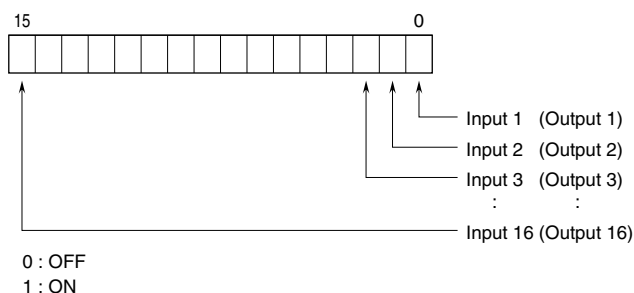

■ COUNT PRESET (models: R3-PA16, R3-PA8)

It is possible to preset the values of each input CH of R3-PA16 and R3-PA8 from R3-NM4 (Ver. 2.00 or later).

For details, refer to R3-PA16 instruction manual (EM-8389) and R3-PA8 instruction manual (EM-8457).

■ MAIN / SUB SWITCHING CONTROL

R3 main network

(main/sub switching control)

Address : 01025 = 1

Address : 01025 = 0

Communication Status

Start

Main Lost

Main Restored

Switching by Host

R3 sub network

(main/sub switching control)

Address : 01025 = 1

Address : 01025 = 0

- 1) When the main/sub switching control for both main and sub network is set to '0,' all contact outputs are off, and analog output modules output -15%.
- 2) When the main's setting is switched to '1,' the output modules are in control of the main host device.
- 3) When a loss of communication is detected in the main network, the output signal is held for the preset time period. (Timer is programmable with the PC Configurator Software, R3CON.) After the time has been elapsed, the output control is switched from the main to the sub network. Be sure to set an appropriate output signal to the sub network and switch the sub's setting to '1' before such switching occurs.
- 4) The output modules' control does not automatically switched back to the main's when the main network is restored if the main's setting is '0.' Be sure to switch the setting back to '1' before the communication is restored.
- 5) When both the main and the sub network modules are in communication, the output can be switched without delay.