

**TOTALIZED PULSE INPUT MODULE**  
(Pi 16 points)MODEL **R3-PA16****BEFORE USE ....**

Thank you for choosing us. Before use, please check contents of the package you received as outlined below.

If you have any problems or questions with the product, please contact our sales office or representatives.

**■ PACKAGE INCLUDES:**

Totalized pulse input module .....(1)

**■ MODEL NO.**

Confirm Model No. marking on the product to be exactly what you ordered.

**■ INSTRUCTION MANUAL**

This manual describes necessary points of caution when you use this product, including installation, connection and basic maintenance procedures.

**POINTS OF CAUTION****■ CONFORMITY WITH EU DIRECTIVES**

- The equipment must be mounted inside the instrument panel of a metal enclosure.
- The actual installation environments such as panel configurations, connected devices, connected wires, may affect the protection level of this unit when it is integrated in a panel system. The user may have to review the CE requirements in regard to the whole system and employ additional protective measures to ensure the CE conformity.  
\* For example, installation of noise filters and clamp filters for the power source, input and output connected to the unit, etc.

**■ HOT SWAPPABLE MODULES**

- Replacing the module does not affect other modules on the same base. Thus, the module can be replaced while the power is ON. However, replacing multiple modules at once may greatly change live voltage levels. We highly recommend to replace them one by one.

**■ GENERAL PRECAUTIONS**

- DO NOT set the switches on the module while the power is supplied. The switches are used only for maintenance without the power.

**■ ENVIRONMENT**

- Indoor use.
- When heavy dust or metal particles are present in the air, install the unit inside proper housing with sufficient ventilation.
- Do not install the unit where it is subjected to continuous vibration. Do not subject the unit to physical impact.
- Environmental temperature must be within -10 to +55°C (14 to 131°F) with relative humidity within 30 to 90% RH in order to ensure adequate life span and operation.

**■ WIRING**

- Do not install cables close to noise sources (relay drive cable, high frequency line, etc.).
- Do not bind these cables together with those in which noises are present. Do not install them in the same duct.

**■ AND ....**

- The unit is designed to function as soon as power is supplied, however, a warm up for 10 minutes is required for satisfying complete performance described in the data sheet.

**INSTALLATION**

Use the Installation Base (model: R3-BSx).

## COMPONENT IDENTIFICATION

### ■ FRONT VIEW

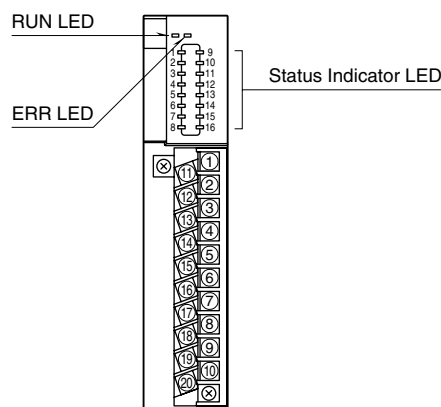

### ■ SIDE VIEW

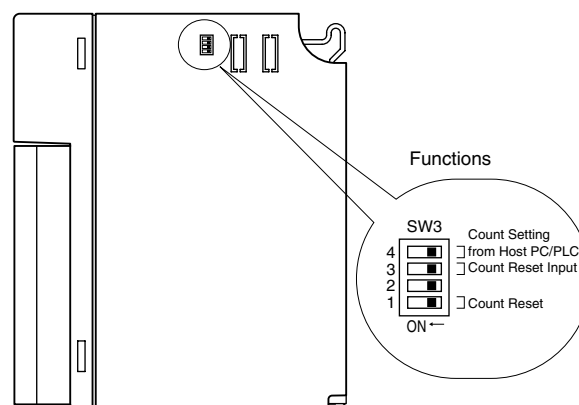

Set the Count Reset SW to OFF to start counting.

### ■ STATUS INDICATOR LED

**RUN indicator:** Bi-color (red/green) LED;

- Red when the bus A operates normally;
- Green when the bus B operates normally;
- Amber when both buses operate normally.

**ERR indicator:** Bi-color (red/green) LED;

- Red with excitation abnormality;
- Green in normal operating conditions.

**Input status indicator:** Red LED; turns on with the input ON.

### ■ SIDE DIP SW

(\*)Factory setting

#### • Count Reset: SW3-1

SW	COUNT RESET	
	NORMAL	COUNT RESET
SW3-1	OFF (*)	ON

Note: Be sure to turn OFF during use.

#### • Count Reset Input: SW3-3

SW	COUNT RESET INPUT	
	INVALID	VALID
SW3-3	OFF (*)	ON

#### • Count Setting from Host PC/PLC: SW3-4

SW	COUNT SETTING FROM HOST PC/PLC	
	COUNT RESET	COUNT PRESET
SW3-4	OFF (*)	ON

(For option /PRS, count preset is ON)

Note : Be sure to set unused SW3-2 to OFF.

## PC CONFIGURATOR

With configurator software, settings shown below are available.

Refer to the software manual of R3CON for detailed operation.

- Max. Pulse count: 1 to 65,535 (factory setting: 10,000)
- Totalized count value (V2.01 or higher)
- Accumulated pulse count (Pulse counts are changeable by using the PC Configurator, refer to "Counter setting from host PC/ PLC" section hereafter.)

---

## FUNCTIONS

### ■ MANUAL COUNT RESET

- 1) Remove Network Module or its cables and interrupt communication with other devices.
- 2) Turn ON the Count Reset SW.
- 3) Return the module to the base and turn the power supply on.
- 4) ERR LED turns on and the module starts resetting its counter. When the resetting is complete, the LED turns to green. DO NOT remove the power while the red LED is on. The RUN LED starts blinking at the same time.
- 5) After the green LED is confirmed, turn the power supply off.
- 6) Turn OFF the Count Reset SW.
- 7) Return the Network module onto the base and turn the power supply on.

Note: Count Reset SW must be turned OFF after this procedure because the module does not start counting with ON state.

### ■ REMOTE COUNT RESET INPUT

With the Count Reset Input SW (SW3-3) turned ON, the Pi 16 pulse input can be used to remotely reset the count values.

SW3-3 = OFF: Pi 16 is used as a pulse input.

SW3-3 = ON: Pi 16 is used to reset the count values for the Pi 1 through Pi 15. One pulse supplied at the Pi 16 will be recognized as a reset signal.

### ■ REMOTE COUNT RESET OPERATION

- 1) ERR LED turns on (red color) when the reset signal is received.
- 2) In 1 second, the module starts resetting its counter. When the resetting is complete, the LED turns to green.
- 3) After 1 second, ERR LED turns back to the state before the reset signal has been received.

Note: Reset signals received while the module is processing (1) through (3) are ignored.

### ■ COUNT RESET FROM HOST PC/PLC

Refer to "COUNTER SETTING FROM HOST PC/PLC" section hereafter.

## COUNTER SETTING FROM HOST PC/PLC

### ■ COUNTER RESET

(Available for R3-NCx, R3-NCIE1, R3-NE1, R3-NMx, R3-NDx, R3-NFL1, R3-NP1, R3-NML3 (Firmware version 2.00 or later, R3-NM3: Firmware version V1.00 or later))

Setting SW3-4 OFF and turning power on enable the function.

The bits indicating the channels to reset counter are allocated in the first word from host PC/PLC.

When these bits are changed from 0 to 1, the counter is reset. When it is confirmed that the counter is reset, return to 0.

Notice that if the bit remains at 1, the next reset will not work.

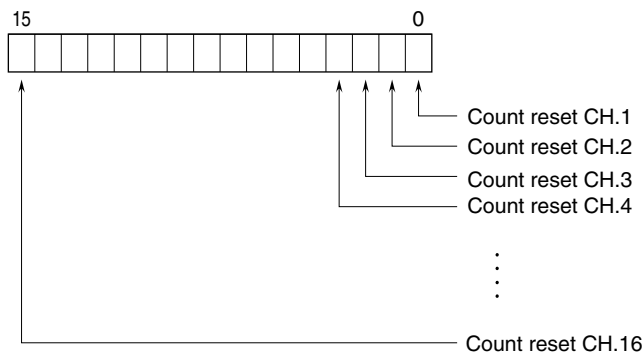

### ■ COUNTER PRESET

(Available in combination with R3-NE1, R3-NMx (Firmware version 2.00 or later, R3-NM3: Firmware version V1.00 or later), and R3-PA16 displayed 'SW3-4 RESET/PRESET' on the right side)

Setting SW3-4 ON and turning power on enable the function.

Write the preset value to the Holding Registers, which has same address as the Input Registers.

When writing the same preset value consecutively, perform the following steps.

- Reset the power of the main unit.
- Temporarily write a different preset value. (e.g. 1000 > 2000 > 1000 etc.)

#### • Input Registers

#### • Holding Registers

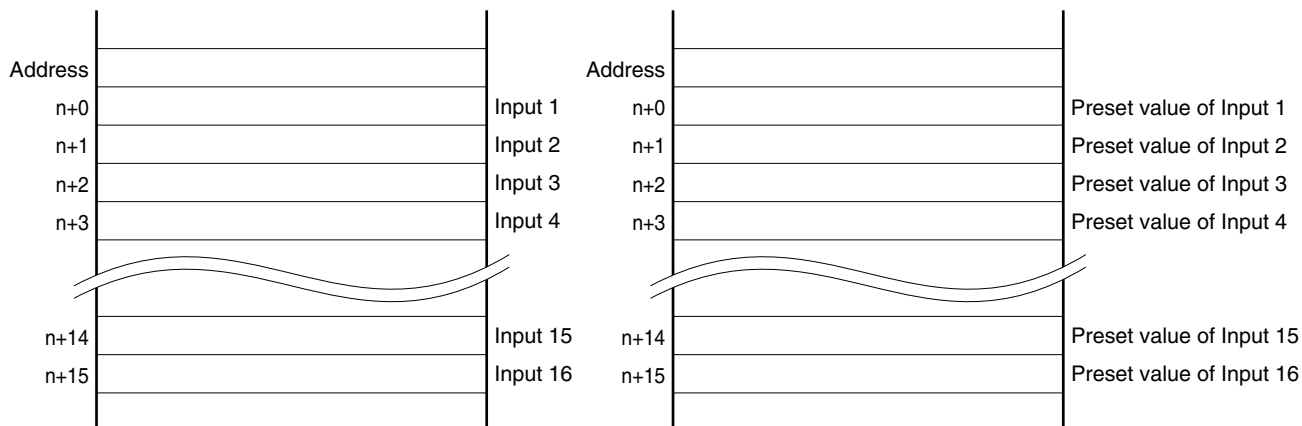

## TERMINAL CONNECTIONS

Connect the unit as in the diagram below.

### EXTERNAL DIMENSIONS unit: mm (inch)

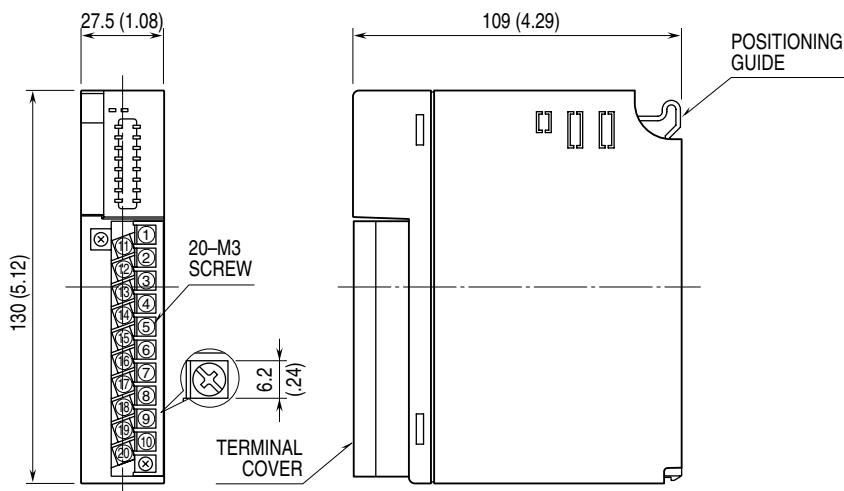

### CONNECTION DIAGRAM

#### R3-PA16x

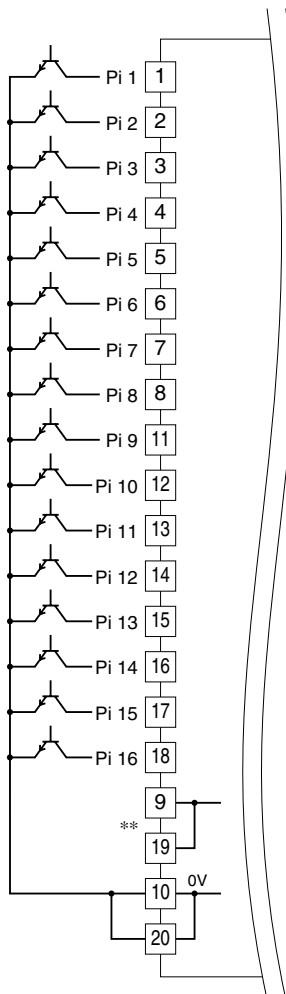

#### R3-PA16x/A

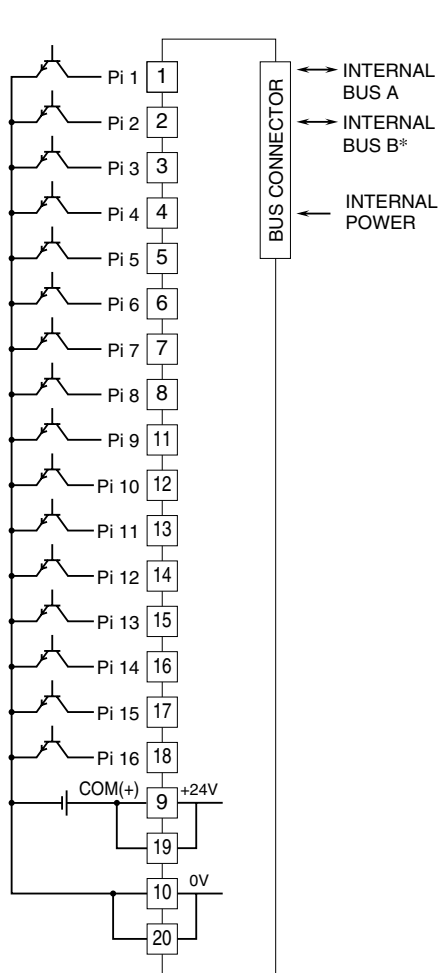

\* For dual redundant communication.  
 \*\*DO NOT use the terminals No. 9 and 19.

## WIRING INSTRUCTIONS

### ■ SCREW TERMINAL

Torque: 0.5 N·m

### ■ SOLDERLESS TERMINAL

Refer to the drawing below for recommended ring tongue terminal size. Spade tongue type is also applicable. Solderless terminals with insulation sleeve do not fit.

Applicable wire size: 0.3 – 0.5 mm<sup>2</sup>

Recommended manufacturer: Japan Solderless Terminal MFG. Co., Ltd., Nichifu Co., Ltd.

