

THERMOCOUPLE INPUT MODULE
(8 points, isolated)MODEL **R3-TS8****BEFORE USE**

Thank you for choosing us. Before use, please check contents of the package you received as outlined below.

If you have any problems or questions with the product, please contact our sales office or representatives.

■ PACKAGE INCLUDES:

Thermocouple input module (body + 8 CJC sensors).....(1)

■ MODEL NO.

Confirm Model No. marking on the product to be exactly what you ordered.

■ INSTRUCTION MANUAL

This manual describes necessary points of caution when you use this product, including installation, connection and basic maintenance procedures.

POINTS OF CAUTION**■ CONFORMITY WITH EU DIRECTIVES**

- The equipment must be mounted inside the instrument panel of a metal enclosure.
- The actual installation environments such as panel configurations, connected devices, connected wires, may affect the protection level of this unit when it is integrated in a panel system. The user may have to review the CE requirements in regard to the whole system and employ additional protective measures to ensure the CE conformity.

■ HOT SWAPPABLE MODULES

- Replacing the module does not affect other modules on the same base. Thus, the module can be replaced while the power is ON. However, replacing multiple modules at once may greatly change live voltage levels. We highly recommend to replace them one by one.

■ GENERAL PRECAUTIONS

- DO NOT set the switches on the module while the power is supplied. The switches are used only for maintenance without the power.

■ ENVIRONMENT

- Indoor use.
- When heavy dust or metal particles are present in the air, install the unit inside proper housing with sufficient ventilation.
- Do not install the unit where it is subjected to continuous vibration. Do not subject the unit to physical impact.
- Environmental temperature must be within -10 to +55°C (14 to 131°F) with relative humidity within 30 to 90% RH in order to ensure adequate life span and operation.

■ WIRING

- Do not install cables close to noise sources (relay drive cable, high frequency line, etc.).
- Do not bind these cables together with those in which noises are present. Do not install them in the same duct.

■ AND

- The unit is designed to function as soon as power is supplied, however, a warm up for 10 minutes is required for satisfying complete performance described in the data sheet.

INSTALLATION

Use the Installation Base (model: R3-BSx).

COMPONENT IDENTIFICATION

■ SIDE VIEW

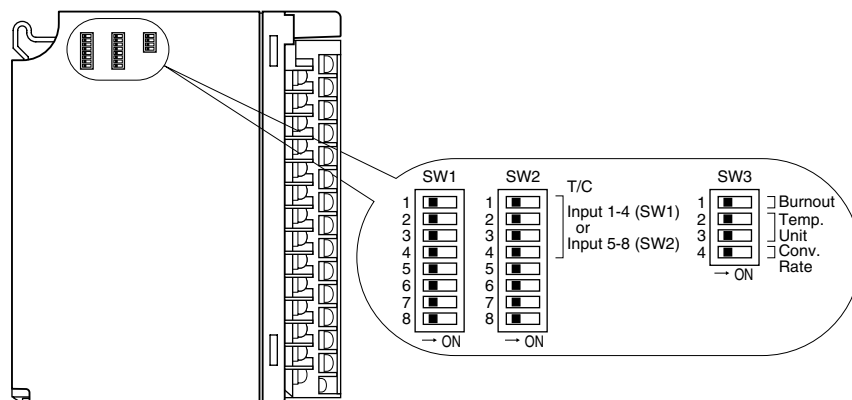

■ FRONT VIEW

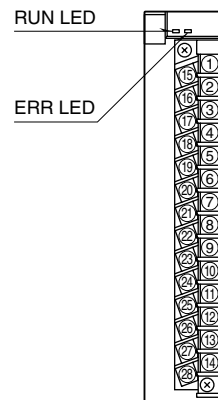

■ SIDE DIP SW

(*) Factory setting

• Thermocouple Type: SW1, SW2 (selectable per 4 channels)

INPUT 1 through INPUT 4 (SW1)				T/C
INPUT 5 through INPUT 8 (SW2)				
1	2	3	4	
OFF	OFF	OFF	OFF	K (CA) (*)
ON	OFF	OFF	OFF	E (CRC)
OFF	ON	OFF	OFF	J (IC)
ON	ON	OFF	OFF	T (CC)
OFF	OFF	ON	OFF	B (RH)
ON	OFF	ON	OFF	R
OFF	ON	ON	OFF	S
ON	ON	ON	OFF	C (WRe 5-26)
OFF	OFF	OFF	ON	N
ON	OFF	OFF	ON	U
OFF	ON	OFF	ON	L
ON	ON	OFF	ON	P (Platinel II)
OFF	OFF	ON	ON	(PR)

• Burnout: SW3-1

SW3-1	BURNOUT
OFF	Upscale (*)
ON	Downscale

• Temperature Unit: SW3-2, 3-3

SW3-2	SW3-3	TEMP. UNIT
OFF	OFF	°C (*)
ON	OFF	°F
OFF	ON	K (Absolute Temp)

• Conversion Rate: SW3-4

SW3-4	CONV. RATE
OFF	250 msec. (*)
ON	1 sec.

Note: Be sure to set unused SW1-5 through 1-8, SW2-5 through 2-8 to OFF.

■ STATUS INDICATOR LED

RUN indicator: Bi-color (red/green) LED;

Red when the bus A operates normally;
Green when the bus B operates normally;
Amber when both buses operate normally.

ERR indicator: Bi-color (red/green) LED;

Red with burnout;
Green in normal operating conditions.

PC CONFIGURATOR

With configurator software, settings shown below are available.
Refer to the software manual of R3CON for detailed operation.

■ CHANNEL INDIVIDUAL SETTING

PARAMETER	AVAILABLE RANGE	DEFAULT SETTING
Zero Scale	-32000 to +32000	0
Full Scale	-32000 to +32000	10000
Zero Adjust	-320.00 to +320.00	0.00
Full Adjust	-32000 to +32000	1.0000
Zero Base	Depends on sensor type	0.00
Full Base	Depends on sensor type	0.00
Unused	0: Enable 1: Disable	0: Enable

■ CHANNEL BATCH SETTING

PARAMETER	AVAILABLE RANGE	DEFAULT SETTING
Limit (V0.10 or higher)	No check mark: Limits to the scaling values equivalent to -15 % to +115 %. Check-marked: Limits within Zero Scale to Full Scale.	No check mark

TERMINAL CONNECTIONS

Connect the unit as in the diagram below.

■ EXTERNAL DIMENSIONS unit: mm (inch)

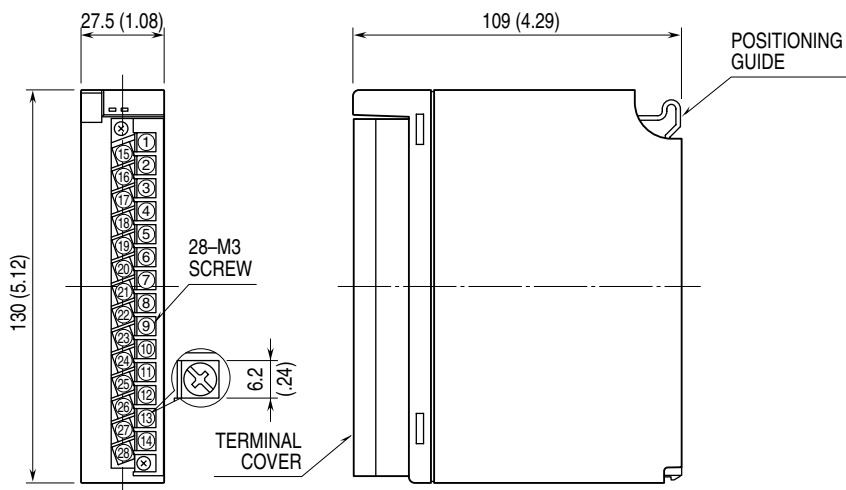

■ CONNECTION DIAGRAM

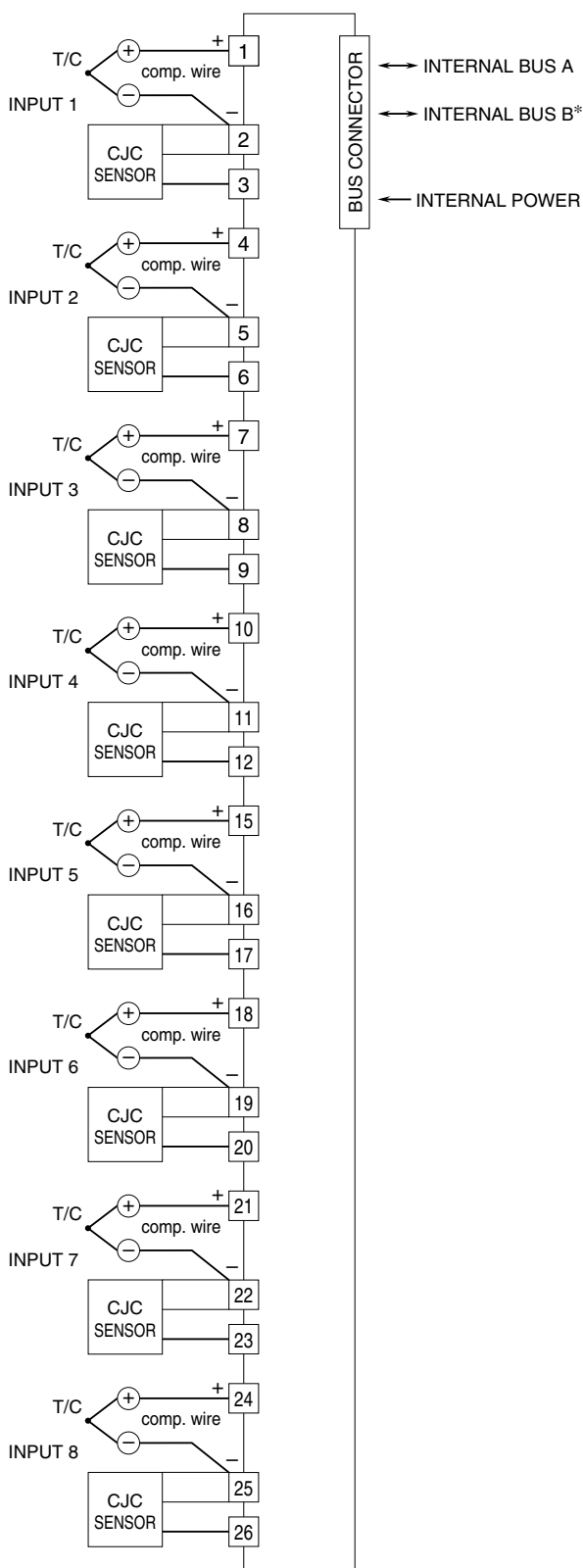

*For dual redundant communication.

● Unused Input Channels

Close across the unused input terminals as shown below.

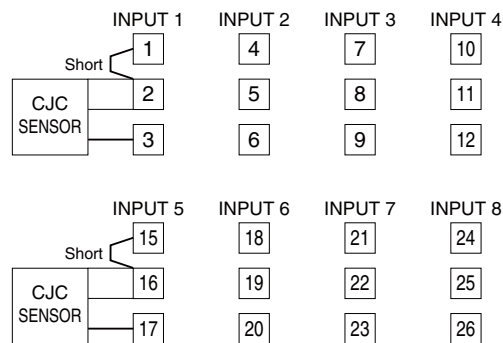

Unused channels left open are equal to the burnout, which turns the red ERR LED on and sets a burnout flag at the PLC or the host device.

When you choose B (RH) thermocouple, shortcircuiting across the terminal may not be effective to cancel the burnout flag. Be sure to use the PC Configurator Software (model: R3CON).

Unused channels can be specified and set so on the PC Configurator Software without needing to short at the field terminals.

WIRING INSTRUCTIONS

■ SCREW TERMINAL

Torque: 0.5 N·m

■ SOLDERLESS TERMINAL

Refer to the drawing below for recommended ring tongue terminal size. Spade tongue type is also applicable. Solderless terminals with insulation sleeve do not fit.

Applicable wire size: 0.3 – 0.5 mm²

Recommended manufacturer: Japan Solderless Terminal MFG. Co., Ltd., Nichifu Co., Ltd.

