

BEFORE USE

Thank you for choosing us. Before use, please check contents of the package you received as outlined below.

If you have any problems or questions with the product, please contact our sales office or representatives.

■ PACKAGE INCLUDES:

DC current output module.....(1)

■ MODEL NO.

Confirm Model No. marking on the product to be exactly what you ordered.

■ INSTRUCTION MANUAL

This manual describes necessary points of caution when you use this product, including installation, connection and basic maintenance procedures.

POINTS OF CAUTION**■ CONFORMITY WITH EU DIRECTIVES**

- The equipment must be mounted inside the instrument panel of a metal enclosure.
- The actual installation environments such as panel configurations, connected devices, connected wires, may affect the protection level of this unit when it is integrated in a panel system. The user may have to review the CE requirements in regard to the whole system and employ additional protective measures to ensure the CE conformity.

■ HOT SWAPPABLE MODULES

- Replacing the module does not affect other modules on the same base. Thus, the module can be replaced while the power is ON. However, replacing multiple modules at once may greatly change live voltage levels. We highly recommend to replace them one by one.

■ GENERAL PRECAUTIONS

- DO NOT set the switches on the module while the power is supplied. The switches are used only for maintenance without the power.

■ ENVIRONMENT

- Indoor use.
- When heavy dust or metal particles are present in the air, install the unit inside proper housing with sufficient ventilation.
- Do not install the unit where it is subjected to continuous vibration. Do not subject the unit to physical impact.
- Environmental temperature must be within -10 to +55°C (14 to 131°F) with relative humidity within 30 to 90% RH in order to ensure adequate life span and operation.

■ WIRING

- Do not install cables close to noise sources (relay drive cable, high frequency line, etc.).
- Do not bind these cables together with those in which noises are present. Do not install them in the same duct.

■ UNUSED OUTPUT CHANNEL

- Close across the unused output terminals or set unused channels to "unused" with PC Configurator software (model:R3CON).

■ AND

- The unit is designed to function as soon as power is supplied, however, a warm up for 10 minutes is required for satisfying complete performance described in the data sheet.

INSTALLATION

Use the Installation Base (model: R3-BSx).

COMPONENT IDENTIFICATION

FRONT VIEW

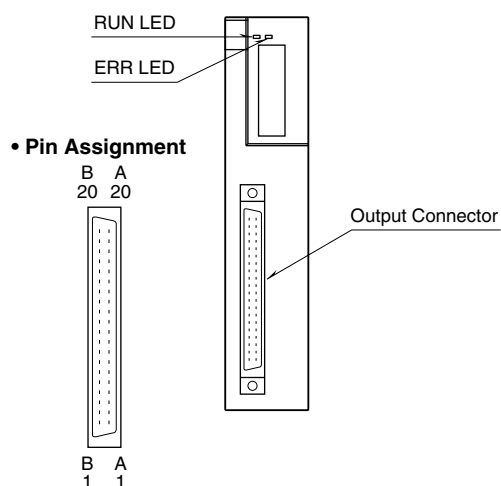

SIDE VIEW

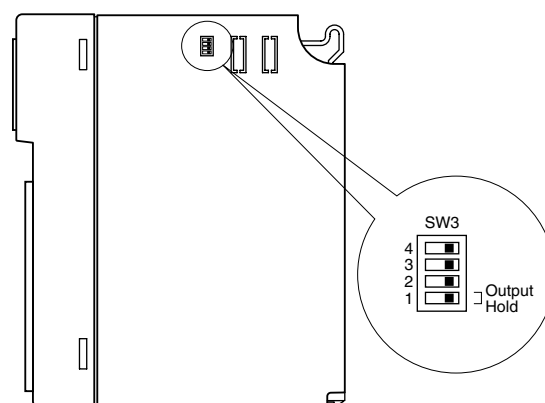

STATUS INDICATOR LED

RUN indicator: Bi-color (red/green) LED;

Red when the bus A operates normally;
Green when the bus B operates normally;
Amber when both buses operate normally.

ERR indicator: Bi-color (red/green) LED;

Red with output abnormality;
Green in normal operating conditions.

SIDE DIP SW

• Output Hold: SW3-1

SW	OUTPUT HOLD	
	HOLD (*)	OFF
SW3-1	OFF	ON

(*) Factory setting

Note: Be sure to set unused SW3-2 through 3-4 to OFF.

PC CONFIGURATOR

With configurator software, settings shown below are available.
Refer to the software manual of R3CON for detailed operation.

CHANNEL INDIVIDUAL SETTING

PARAMETER	AVAILABLE RANGE	DEFAULT SETTING
Zero Scale	-32000 to +32000	0
Full Scale	-32000 to +32000	10000
Zero Adjust	-320.00 to +320.00	0.00
Full Adjust	-32000 to +32000	1.0000
Unused	0: Enable 1: Disable	0: Enable

TERMINAL CONNECTIONS

Connect the unit as in the diagram below.

EXTERNAL DIMENSIONS unit: mm (inch)

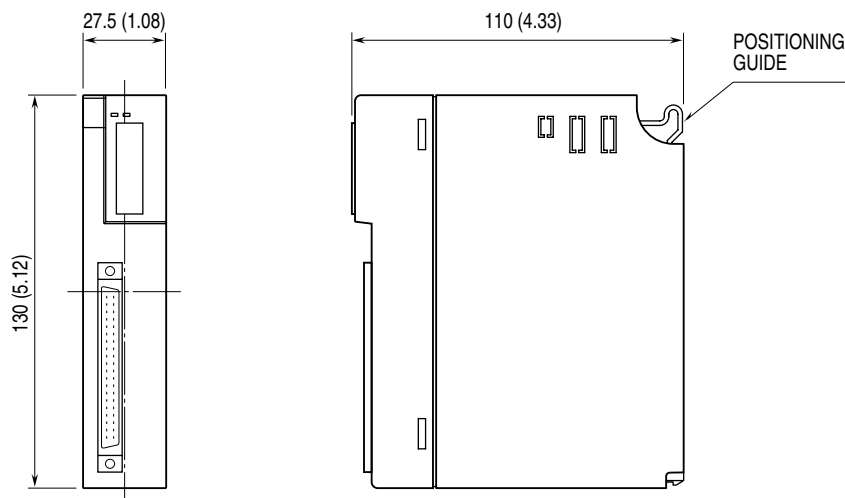

CONNECTION DIAGRAM

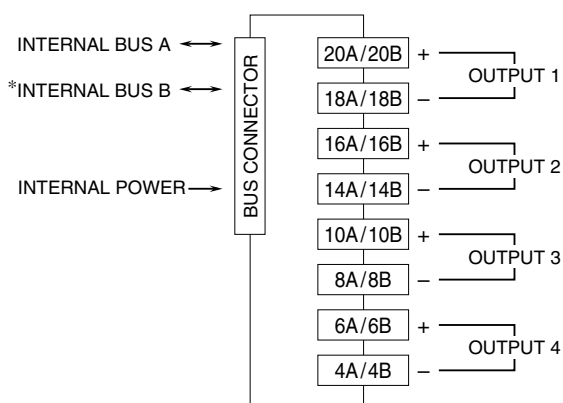

*For dual redundant communication.

Unused Output Channels

Close across the unused output terminals as shown below.

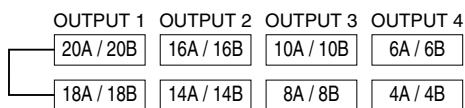

Unused channels left open are equal to the wire breakdown, which turns the red ERR LED on and sets a burnout flag at the PLC or the host device.

Unused channels can be specified and set so on the PC Configurator Software (model: R3CON) without needing to short at the field terminals.

OUTPUT CONNECTOR (40-pin)

PIN NO.	ASSIGNMENT	PIN NO.	ASSIGNMENT
1A	NC	1B	NC
2A	NC	2B	NC
3A	NC	3B	NC
4A	- OUT4	4B	- OUT4
5A	NC	5B	NC
6A	+ OUT4	6B	+ OUT4
7A	NC	7B	NC
8A	- OUT3	8B	- OUT3
9A	NC	9B	NC
10A	+ OUT3	10B	+ OUT3
11A	NC	11B	NC
12A	NC	12B	NC
13A	NC	13B	NC
14A	- OUT2	14B	- OUT2
15A	NC	15B	NC
16A	+ OUT2	16B	+ OUT2
17A	NC	17B	NC
18A	- OUT1	18B	- OUT1
19A	NC	19B	NC
20A	+ OUT1	20B	+ OUT1

FUNCTIONS

OUTPUT HOLD or OUTPUT OFF

In normal conditions, the module outputs the signal from the preferred bus A.

When an error is detected, the output is switched to the data from the bus B.

Output Hold

If both are in error, the module holds the signal and stands by until one of the communications recovers.

Output OFF

If both are in error, the module outputs -15 % and stands by until one of the communications recovers.

At the startup, it outputs -15 % until the communication is established and normal data is received.