

**BEFORE USE ....**

Thank you for choosing us. Before use, please check contents of the package you received as outlined below. If you have any problems or questions with the product, please contact our sales office or representatives.

**■ PACKAGE INCLUDES:**

DC voltage/current input module.....(1)

**■ MODEL NO.**

Confirm that the model number described on the product is exactly what you ordered.

**■ INSTRUCTION MANUAL**

This manual describes necessary points of caution when you use this product, including installation, connection and basic maintenance procedures.

**POINTS OF CAUTION**

**■ CONFORMITY WITH EU DIRECTIVES**

- The actual installation environments such as panel configurations, connected devices and connected wires may affect the protection level of this unit when it is integrated in a panel system. The user may have to review the CE requirements in regard to the whole system and employ additional protective measures to ensure CE conformity.

**■ POWER INPUT RATING & OPERATIONAL RANGE**

- Locate the power input rating marked on the product and confirm its operational range as indicated below:  
24V DC rating: 24V ±10%, approx. 97mA

**■ GENERAL PRECAUTIONS**

- Before you remove the unit or mount it, turn off the power supply and input signal for safety.

**■ ENVIRONMENT**

- Indoor use
- When heavy dust or metal particles are present in the air, install the unit inside proper housing with sufficient ventilation.
- Do not install the unit where it is subjected to continuous vibration. Do not subject the unit to physical impact.
- Environmental temperature must be within -10 to +55°C (14 to 131°F) with relative humidity within 30 to 90% RH in order to ensure adequate life span and operation.

**■ WIRING**

- Do not install cables close to noise sources (relay drive cable, high frequency line, etc.).
- Do not bind these cables together with those in which noises are present. Do not install them in the same duct.

**■ AND ....**

- The unit is designed to function as soon as power is supplied, however, a warm up for 10 minutes is required for satisfying complete performance described in the data sheet.

**COMPONENT IDENTIFICATION**

**■ SIDE VIEW**

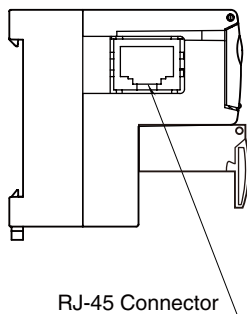

**■ FRONT VIEW**

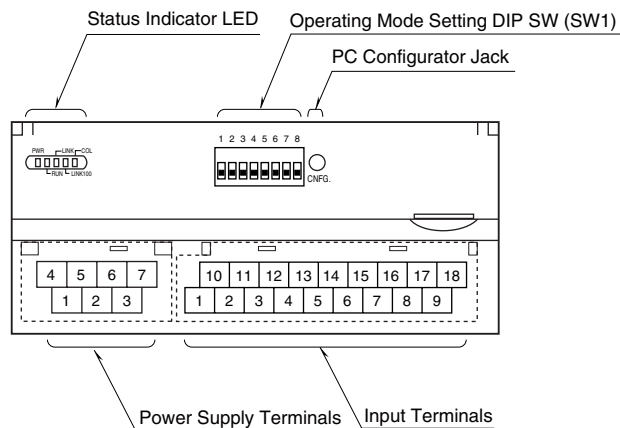

### ■ STATUS INDICATOR LED

ID	COLOR	FUNCTION
PWR	Green	Turns on when the internal 5V is supplied normally.
RUN	Green	Turns on in normal communications conditions.
LINK	Green	Turns on in LINK status.
LINK100	Green	Turns on when connected in 100 Mbps. *1
COL	Green	Blinks in case of collisions.

\*1. Used only in 100BASE link. Dark in 10BASE link.

### ■ EXTENSION MODULE

Combination with all the extension modules is available.

### ■ OPERATING MODE

(\*) Factory setting

#### • Extension (SW1-1, 1-2)

SW1-1	SW1-2	Extension
OFF	OFF	No extension (*)
ON	OFF	Discrete input, 8 or 16 points
OFF	ON	Discrete output, 8 or 16 points

#### • Conversion Rate / Accuracy (SW1-3, 1-4)

SW1-3	SW1-4	Conversion rate / Accuracy
OFF	OFF	80 msec. / $\pm 0.1\%$ (*)
ON	OFF	40 msec. / $\pm 0.2\%$
OFF	ON	20 msec. / $\pm 0.4\%$
ON	ON	10 msec. / $\pm 0.8\%$

#### • Input Range (SW1-5, 1-6, 1-7, 1-8)

SW1-5	SW1-6	SW1-7	SW1-8	Input range
OFF	OFF	OFF	OFF	-10 – +10V DC (*)
ON	OFF	OFF	OFF	-5 – +5V DC
OFF	ON	OFF	OFF	-1 – +1V DC
ON	ON	OFF	OFF	0 – 10V DC
OFF	OFF	ON	OFF	0 – 5V DC
ON	OFF	ON	OFF	1 – 5V DC
OFF	ON	ON	OFF	0 – 1V DC
ON	ON	ON	OFF	-0.5 – +0.5V DC
ON	OFF	OFF	ON	-20 – +20mA DC
OFF	ON	OFF	ON	4 – 20mA DC
ON	ON	OFF	ON	0 – 20mA DC
ON	ON	ON	ON	PC Configurator setting

### ■ POWER SUPPLY TERMINAL ASSIGNMENT

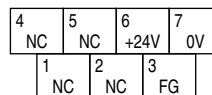

NO.	ID	FUNCTION, NOTES
1	NC	----
2	NC	----
3	FG	FG
4	NC	----
5	NC	----
6	+24V	Power input (24V DC)
7	0V	Power input (0V)

### ■ INPUT TERMINAL ASSIGNMENT

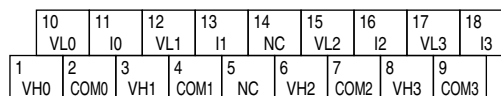

NO.	ID	FUNCTION	NO.	ID	FUNCTION
1	VH0	Wide span volt. 0	10	VL0	Narrow span volt. 0
2	COM0	Common 0	11	I0	Current range 0
3	VH1	Wide span volt. 1	12	VL1	Narrow span volt. 1
4	COM1	Common 1	13	I1	Current range 1
5	NC	No connection	14	NC	No connection
6	VH2	Wide span volt. 2	15	VL2	Narrow span volt. 2
7	COM2	Common 2	16	I2	Current range 2
8	VH3	Wide span volt. 3	17	VL3	Narrow span volt. 3
9	COM3	Common 3	18	I3	Current range 3

### ■ PC CONFIGURATOR

The PC Configurator software (model: R7CON) is used to set the ethernet communication setting and check the firmware version and settings. The following parameters for each channel can be set.

#### • SETTINGS FOR INDIVIDUAL CHANNELS

Input range  
Zero / Full scale  
Gain / Bias  
Zero / Full base

#### • SETTINGS FOR ALL CHANNELS

IP address  
Subnet mask

Before starting programming analog input modules, turn on the front SW1-5 through 1-8. For more information about the programming using the R7CON, please refer to the R7CON Users Manual.

## EXTERNAL DIMENSIONS unit: mm (inch)

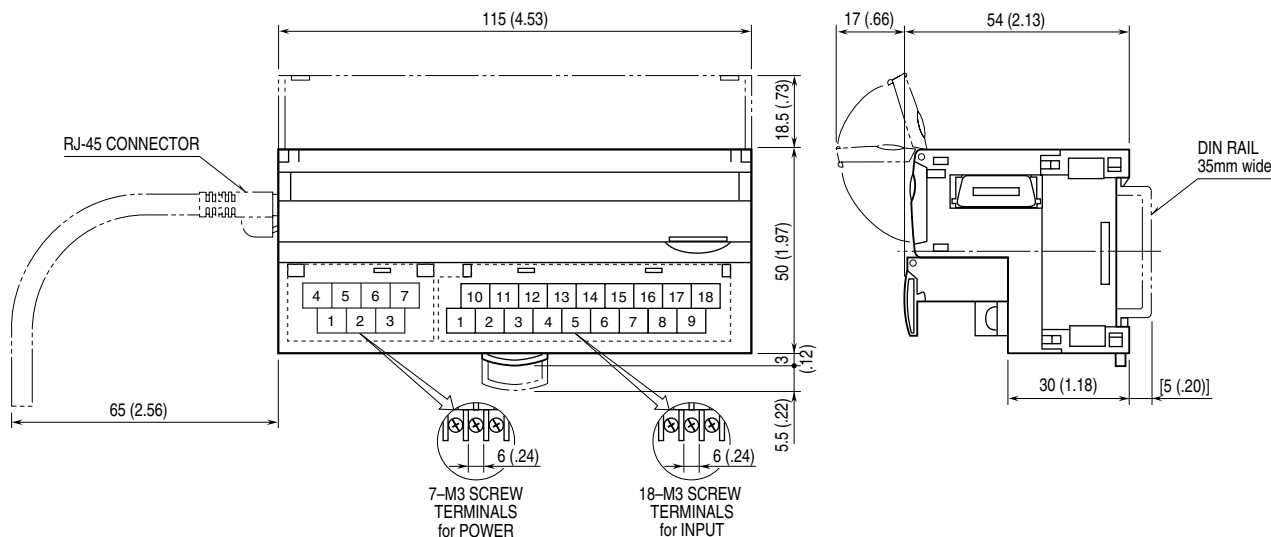

## CONNECTION DIAGRAM

Connect the unit as in the diagram below.

Note: In order to improve EMC performance, bond the FG terminal to ground.

Caution: FG terminal is NOT a protective conductor terminal.

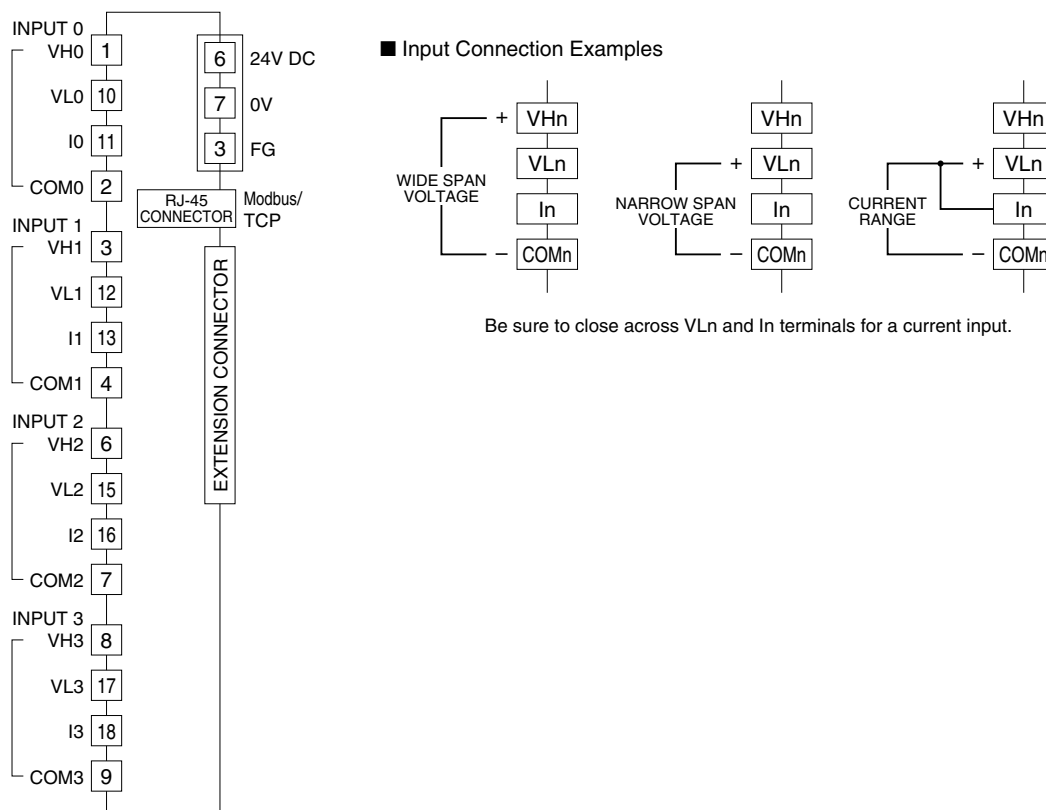

### INPUT RANGE

- **Wide span voltage:** -10 – +10V DC, -5 – +5V DC, 0 – 10V DC, 0 – 5V DC, 1 – 5V DC
- **Narrow span voltage:** -1 – +1V DC, 0 – 1V DC, -0.5 – +0.5V DC
- **Current:** -20 – +20mA DC, 0 – 20mA DC, 4 – 20mA DC

## WIRING INSTRUCTIONS

### ■ SCREW TERMINAL

Torque: 0.5 N·m

### ■ SOLDERLESS TERMINAL mm (inch)

Refer to the drawing below for recommended ring tongue terminal size. Spade tongue type is also applicable.

Applicable wire size: 0.25 to 1.65 mm<sup>2</sup> (AWG22 to 16)

Recommended manufacturer: Japan Solderless Terminal MFG. Co.,Ltd., Nichifu Co.,Ltd.

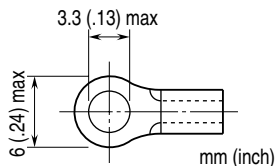

## CONFIRMING ETHERNET CONNECTION

### ■ IP ADDRESS

The R7E does not support BootP Table Software. The IP Address and Subnet Mask can be configured using the R7CON Configurator Software.

The Modbus/TCP Port No. is fixed at 502.

### ■ CHECK WIRING

Connect an Ethernet cable to the RJ-45 connector.

### ■ CHECK LED

When wiring is correct, LINK is turned on. When the module is connected in 100 Mbps, LINK100 is blinking.\*

\*. For firmware revision V0.20 or later, LINK100 is ON.

### ■ CHECK R7E CONNECTION

Enter "ping command" on the Windows MS-DOS as follows:

```
C:¥WINDOWS>ping ***.***.***.***
(***.***.***.***: Enter IP address in decimal.)
```

```
ping ***.***.***.*** with 32 bytes of data:
Reply from ***.***.***.*** : bytes=32 time<10ms TTL=64
Reply from ***.***.***.*** : bytes=32 time<10ms TTL=64
Reply from ***.***.***.*** : bytes=32 time<10ms TTL=64
Reply from ***.***.***.*** : bytes=32 time<10ms TTL=64
```

```
Ping statistics for ***.***.***.***
Packets: Sent=4, Received=4, Lost=0 (0% loss)
```

Replies in case of normal connection are as shown above. If the connection cannot be established normally due to e.g. wrong IP address, other replies such as 'timeout' will be received.

### ■ CHECK CONNECTION TO THE APPLICATION SOFTWARE

#### Check Point 1: LINK LEDs

When normal connection with PC, PLC or hub is established, the front LINK and LINK100 (when connected in 100 Mbps) is/are turned on regardless of data sending/receiving status. Check power supply to the switch/hub in case that these LEDs are not on.

#### Check Point 2: RUN Indicator LED

A green light turns on at the RUN Indicator LED in normal data sending/receiving with an application.

## MODBUS FUNCTION CODES & SUPPORTED CODES

### ■ Data and Control Functions

CODE	NAME		
01	Read Coil Status	X	Digital output from the slave (read/write)
02	Read Input Status	X	Status of digital inputs to the slave (read only)
03	Read Holding Registers	X	General purpose register within the slave (read/write)
04	Read Input Registers	X	Collected data from the field by the slave (read only)
05	Force Single Coil	X	Digital output from the slave (read/write)
06	Preset Single Registers	X	General purpose register within the slave (read/write)
07	Read Exception Status		
08	Diagnostics	X	
09	Program 484		
10	Poll 484		
11	Fetch Comm. Event Counter	X	Fetch a status word and an event counter
12	Fetch Comm. Event Log	X	A status word, an event counter, a message count and a field of event bytes
13	Program Controller		
14	Poll Controller		
15	Force Multiple Coils	X	Digital output from the slave (read/write)
16	Preset Multiple Registers	X	General purpose register within the slave (read/write)
17	Report Slave ID	X	Slave type / 'RUN' status
18	Program 884/M84		
19	Reset Comm. Link		
20	Read General Reference		
21	Write General Reference		
22	Mask Write 4X Register		
23	Read/Write 4X Register		
24	Read FIFO Queue		

### ■ Exception Codes

CODE	NAME		
01	Illegal Function	X	Function code is not allowable for the slave
02	Illegal Data Address	X	Address is not available within the slave
03	Illegal Data Value	X	Data is not valid for the function
04	Slave Device Failure		
05	Acknowledge		
06	Slave Device Busy		
07	Negative Acknowledge		
08	Memory Parity Error		

### ■ Diagnostic Subfunctions

CODE	NAME		
00	Return Query Data	X	Loop back test
01	Restart Comm. Option		
02	Return Diagnostic Register		
03	Change ASCII Input Delimiter		
04	Force Listen Only Mode		

## MODBUS I/O ASSIGNMENTS

	ADDRESS	DATA TYPE	DATA
Coil (0X)	1 – 16		Digital Output (discrete output of the basic module)
	17 – 32		Digital Output (discrete output of the extension module)
Inputs (1X)	1 – 16		Digital Input (discrete input of the basic module)
	17 – 32		Digital Input (discrete input of the extension module)
	33 – 48		Reserved (unused)
	49 – 64		Module Status
	65 – 80		Reserved (unused)
Input Registers (3X)	1 – 4	I	Analog Input
	5 – 16	----	Reserved (unused)
	17 – 24	F	Analog Input
	25 – 48	----	Reserved (unused)
Holding Registers (4X)	1 – 2	I	Analog Output
	3 – 16	----	Reserved (unused)
	17 – 20	F	Analog Output
	21 – 48	----	Reserved (unused)

I : Integer, -1500 – +11500 (-15 – +115%)

F : Floating

Note: DO NOT access addresses other than mentioned above. Such access may cause problems such as inadequate operation.

### ■ STATUS

Analog input modules (models: R7E-SV4, R7E-TS4, R7E-RS4, R7E-MS4, R7E-CT4E) can show input status of each channel. Analog output modules (models: R7E-YS2, R7E-YV2) and discrete I/O modules (models: R7E-DA16, R7E-DC16A, R7E-DC16B) shows '0' at the same address.

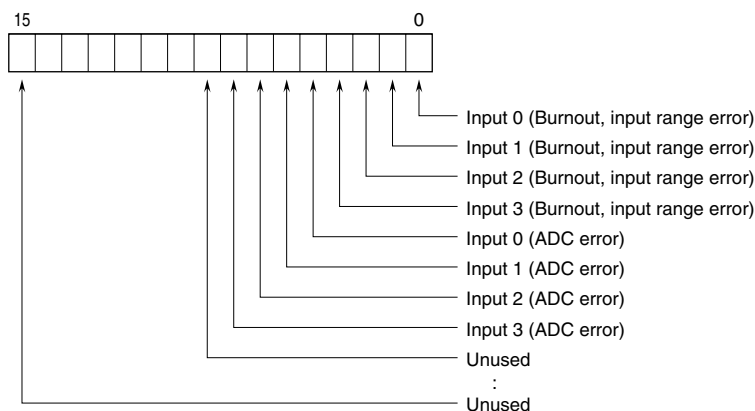

Burnout, input range error ( $\leq -15\%$ ,  $\geq +115\%$ )

0 : Normal 1 : Error

ADC error (no response from ADC)

0 : Normal 1 : Error