

**CC-Link I/O MODULE**  
(PNP discrete input & PNP transistor output,  
8 points each, tension clamp terminal block)MODEL **R7F4DC-DAC16D-C****BEFORE USE ....**

Thank you for choosing us. Before use, please check contents of the package you received as outlined below. If you have any problems or questions with the product, please contact our sales office or representatives.

**■ PACKAGE INCLUDES:**

Discrete I/O module .....(1)  
DIN rail mounter slider .....(2)

**■ MODEL NO.**

Confirm Model No. marking on the product to be exactly what you ordered.

**■ INSTRUCTION MANUAL**

This manual describes necessary points of caution when you use this product, including installation, connection and basic maintenance procedures.

**■ CSP+ file**

CSP+ file is downloadable at our web site or CC-Link Partner Association's web site (<https://www.cc-link.org>).

**POINTS OF CAUTION****■ CONFORMITY WITH EU DIRECTIVES**

- The equipment must be mounted inside the instrument panel of a metal enclosure.
- The actual installation environments such as panel configurations, connected devices, connected wires, may affect the protection level of this unit when it is integrated in a panel system. The user may have to review the CE requirements in regard to the whole system and employ additional protective measures\* to ensure the CE conformity.

\* For example, installation of noise filters and clamp filters for the power source, input and output connected to the unit, etc.

**■ POWER INPUT RATING & OPERATIONAL RANGE**

- Locate the power input rating marked on the product and confirm its operational range as indicated below:  
24V DC rating: 24V ±10%, approx. 30 mA

**■ GENERAL PRECAUTIONS**

- Before you remove the unit or mount it, turn off the power supply and I/O signal for safety.
- Before you remove the connector or mount it, make sure to turn off the power supply and I/O signal for safety.
- DO NOT set the switches on the module while the power is supplied. The switches are used only for maintenance without the power.

**■ ENVIRONMENT**

- Indoor use.
- When heavy dust or metal particles are present in the air, install the unit inside proper housing with sufficient ventilation.
- Do not install the unit where it is subjected to continuous vibration. Do not subject the unit to physical impact.
- Environmental temperature must be within -10 to +55°C (14 to 131°F) with relative humidity within 30 to 90% RH in order to ensure adequate life span and operation.
- With vertical mounting, for heat dissipation leave at least 10 mm (.39 in.) at the both side of the unit.

**■ WIRING**

- Do not install cables close to noise sources (relay drive cable, high frequency line, etc.).
- Do not bind these cables together with those in which noises are present. Do not install them in the same duct.

**■ AND ....**

- The unit is designed to function as soon as power is supplied, however, a warm up for 10 minutes is required for satisfying complete performance described in the data sheet.

## COMPONENT IDENTIFICATION

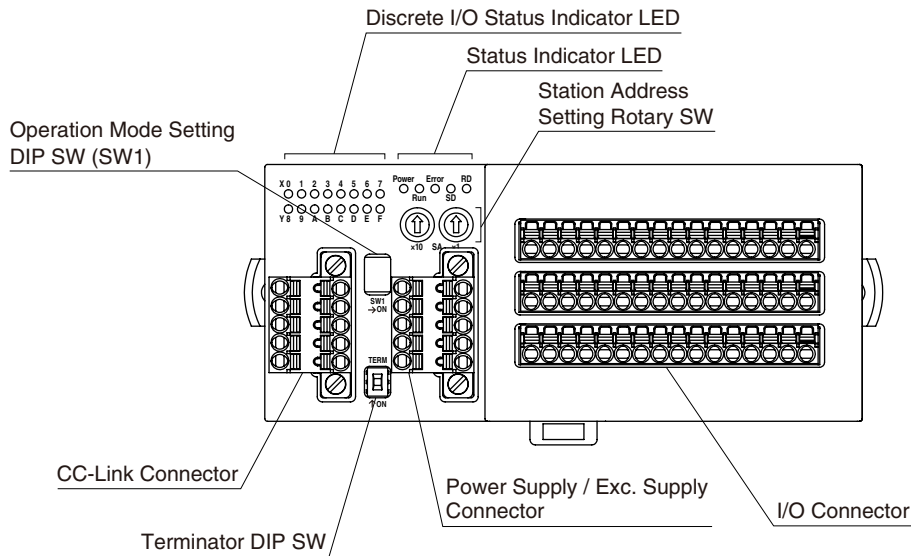

### ■ STATUS INDICATOR LED

ID	COLOR	FUNCTION
Power	Green	ON when internal 5V power is in normal status.
Run	Green	ON when the communication is normal*1
Error	Red	ON when the received data is abnormal.
SD	Green	ON when the module is transmitting.
RD	Green	ON when the module is receiving.

\*1. Run LED turns off when no command is received from the master device.

### ■ DISCRETE I/O STATUS INDICATOR LED

Green LED shows the I/O status.

ON : LED ON  
OFF : LED OFF

### ■ STATION ADDRESS

The left switch determines the tenth place digit, while the right one does the ones place digit of the station address (1 - 64).

(Factory setting: 00)

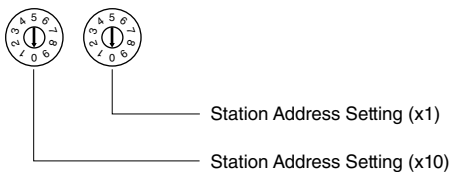

### ■ OPERATING MODE

(\*) Factory setting

#### • Baud Rate (SW1-1, 1-2, 1-3)

Baud Rate is selected with the DIP switch

BAUD RATE	SW1		
	1	2	3
156 kbps (*)	OFF	OFF	OFF
625 kbps	ON	OFF	OFF
2.5 Mbps	OFF	ON	OFF
5 Mbps	ON	ON	OFF
10 Mbps	OFF	OFF	ON

#### • Output at the Loss of Communication (SW1-4)

OUTPUT AT THE LOSS OF COMMUNICATION	SW1
	4
Output clear (output OFF)	OFF
Hold the output (*) (maintains the last data received normally)	ON

### ■ TERMINATING RESISTOR

To use the terminating resistor, turn the switch ON, and OFF to invalidate. (Factory setting OFF)

## ■ STATUS INDICATOR LED

PWR	RUN	ERR	SD *1	RD	STATUS *2
ON	ON	BL	BL	ON	Communicates normally with occasional CRC errors due to noise interference.
ON	ON	BL	BL	ON	Communicates normally but the Baud Rate and/or Station Address switches failed. ERR LED blinks approximately in 0.5 seconds intervals.
ON	ON	BL	BL	OFF	----
ON	ON	BL	OFF	ON	CRC error detected in the received data. Unable to respond.
ON	ON	BL	OFF	OFF	----
ON	ON	OFF	BL	ON	Normal communication
ON	ON	OFF	BL	OFF	----
ON	ON	OFF	OFF	ON	Unable to receive data addressed to the station.
ON	ON	OFF	OFF	OFF	----
ON	OFF	BL	BL	ON	Polling response is made but CRC error is detected in received refresh data.
ON	OFF	BL	BL	OFF	----
ON	OFF	BL	OFF	ON	CRC error detected in the data addressed to the station.
ON	OFF	BL	OFF	OFF	----
ON	OFF	OFF	BL	ON	Link is not started.
ON	OFF	OFF	BL	OFF	----
ON	OFF	OFF	OFF	ON	No data addressed to the station. Or unable to receive data addressed to the station due to noise interference. (Missing parts of the data sent from the master)
ON	OFF	OFF	OFF	OFF	Unable to receive data due to wire breakdown
ON	OFF	ON	OFF	ON/OFF	Faulty Baud Rate and/or Station Address setting
OFF	OFF	OFF	OFF	OFF	Power input removed or power supply failure.

OFF = OFF, ON = ON, BL = Blinking

\*1. SD LED which is blinking may appear to be ON with high baud rate especially when fewer modules are connected.

\*2. LED combinations indicated with "----" do not occur in normal operation unless LED failure or the like occurs.

## ■ TERMINAL ASSIGNMENTS

### • CC-Link, Power Supply, Exc. Supply Assignment

Unit side connector: MCV1,5/5-GF-3,5 (Phoenix contact)

Cable side connector: TFMC1,5/5-STF-3,5 (Phoenix contact)

Applicable wire size: 0.2 - 1.5mm<sup>2</sup>

Stripped length: 10mm

Recommended solderless terminal:

AI0,25-10YE 0.25mm<sup>2</sup> (Phoenix contact)

AI0,34-10TQ 0.34mm<sup>2</sup> (Phoenix contact)

AI0,5-10WH 0.5mm<sup>2</sup> (Phoenix contact)

AI0,75-10GY 0.75mm<sup>2</sup> (Phoenix contact)

AI1-10 1.0mm<sup>2</sup> (Phoenix contact)

AI1,5-10 1.5mm<sup>2</sup> (Phoenix contact)

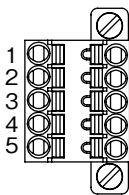

### • CC-Link

PIN NO.	ID	FUNCTION
1	FE	Function earth
2	SLD	Shield
3	DB	DB
4	DG	DG
5	DA	DA

Note: The numbers marked on the connector have no relationship to the pin number of the unit. Wire according to the instruction manual of the unit.

### • POWER SUPPLY / EXC. SUPPLY

PIN NO.	ID	FUNCTION
1	PWR+	Power supply +
2	PWR-	Power supply -
3	FE1	Grounding
4	SNSR.EXC+	Exc. supply +
5	SNSR.EXC-	Exc. supply -

### • I/O Terminal Assignment

Unit side connector: MCV1,5/16-G-3,5 (Phoenix Contact)

Cable side connector: FMC1,5/16-ST-3,5 (Phoenix Contact)

Applicable wire size: 0.2 - 1.5mm<sup>2</sup>

Stripped length: 10mm

Recommended solderless terminal

AI0,25-10YE 0.25mm<sup>2</sup> (Phoenix Contact)

AI0,34-10TQ 0.34mm<sup>2</sup> (Phoenix Contact)

AI0,5-10WH 0.5mm<sup>2</sup> (Phoenix Contact)

AI0,75-10GY 0.75mm<sup>2</sup> (Phoenix Contact)

AI1-10 1.0mm<sup>2</sup> (Phoenix Contact)

AI1,5-10 1.5mm<sup>2</sup> (Phoenix Contact)

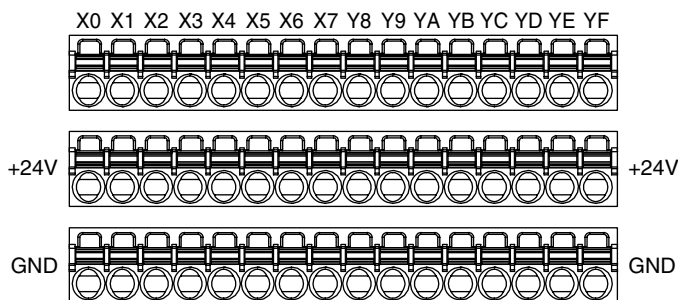

PIN NO.	ID	FUNCTION	PIN NO.	ID	FUNCTION
X0	1	X0	Y8	1	Y8
	2	+24V		2	+24V
	3	GND		3	GND
X1	1	X1	Y9	1	Y9
	2	+24V		2	+24V
	3	GND		3	GND
X2	1	X2	YA	1	YA
	2	+24V		2	+24V
	3	GND		3	GND
X3	1	X3	YB	1	YB
	2	+24V		2	+24V
	3	GND		3	GND
X4	1	X4	YC	1	YC
	2	+24V		2	+24V
	3	GND		3	GND
X5	1	X5	YD	1	YD
	2	+24V		2	+24V
	3	GND		3	GND
X6	1	X6	YE	1	YE
	2	+24V		2	+24V
	3	GND		3	GND
X7	1	X7	YF	1	YF
	2	+24V		2	+24V
	3	GND		3	GND

## MOUNTING INSTRUCTIONS

### ■ DIN RAIL MOUNTING (PARALLEL)

#### • Mounting

- A) Set the upper hook at the rear side of the unit on the DIN rail.
- B) Push in the lower.

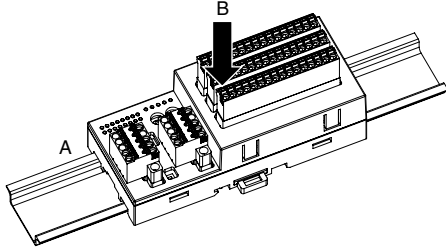

#### • Dismounting

- A) Push down the DIN rail mounter slider with tip of a minus screwdriver.
- B) Pull the lower of the unit.
- C) Remove the upper hook of the unit from the DIN rail.

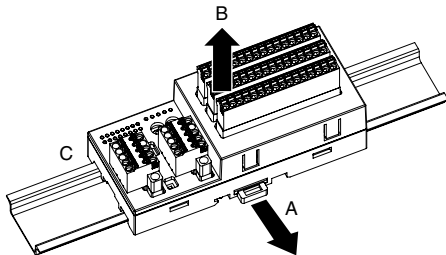

### ■ DIN RAIL MOUNTING (RIGHT ANGLE)

#### • Mounting

- A) Insert the longer DIN rail mounter slider until it clicks twice, as shown below.

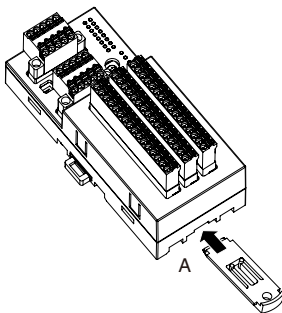

- B) Set the upper hook at the rear side of the unit on the DIN rail.
- C) Push in the lower.

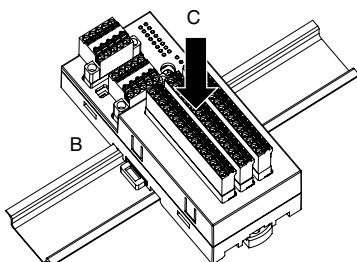

#### • Dismounting

- A) Push down the DIN rail mounter slider with tip of a minus screwdriver.
- B) Pull the lower of the unit.
- C) Remove the upper hook of the unit from the DIN rail.

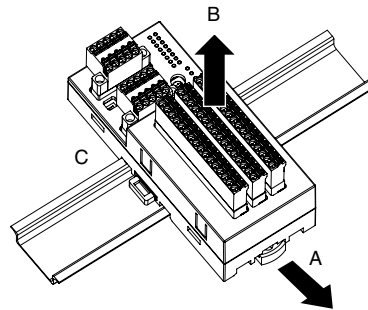

### ■ SURFACE MOUNTING

- A) Insert the two DIN rail mounter sliders until it clicks once, as shown below.

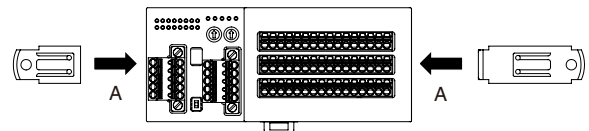

- B) Mount the unit with M4 screws referring the External Dimensions. (Torque: 1.4 N·m)

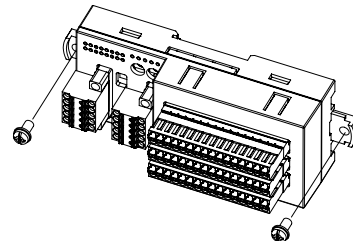

Note: leave at least 10 mm (.39 in.) at the both side of the unit.

# TERMINAL CONNECTIONS

Connect the unit as in the diagram below.

## EXTERNAL DIMENSIONS unit: mm [inch]

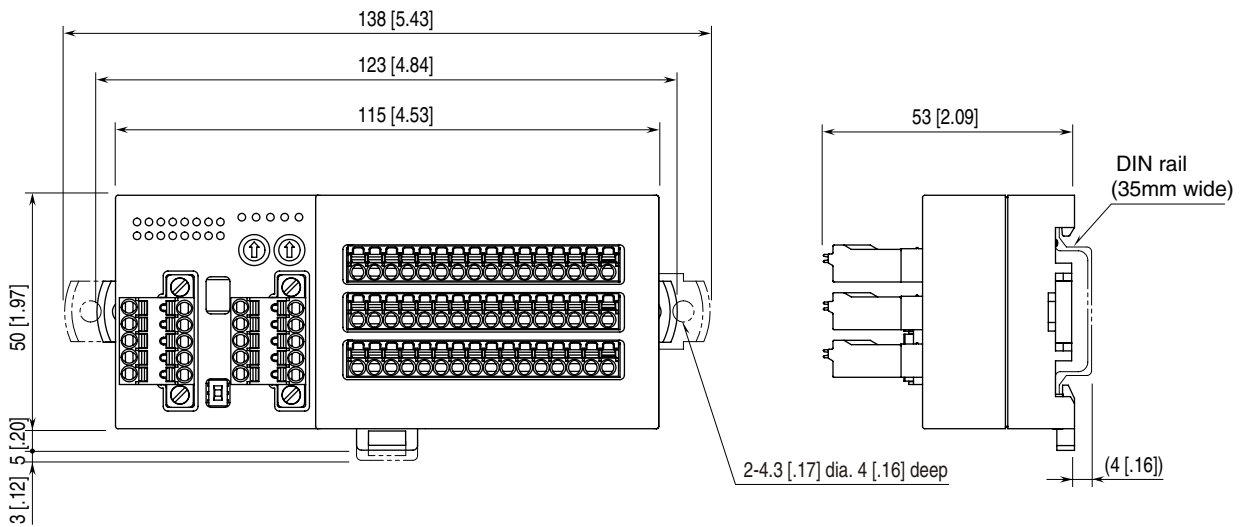

## CONNECTION DIAGRAM

Note: In order to improve EMC performance, bond the FE1 terminal to ground.  
 Caution: FE1 terminal is NOT a protective conductor terminal.

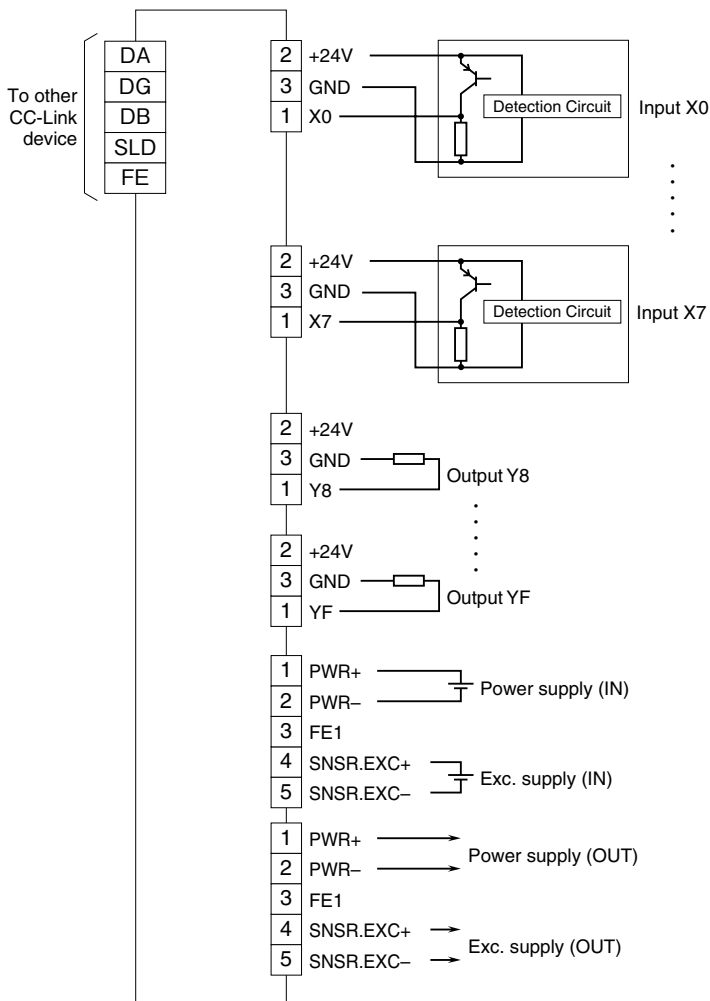

## 2-WIRE SENSOR

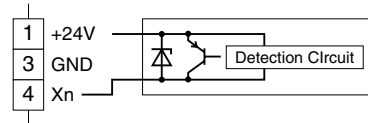

## MOUNTING REQUIREMENTS unit: mm [inch]

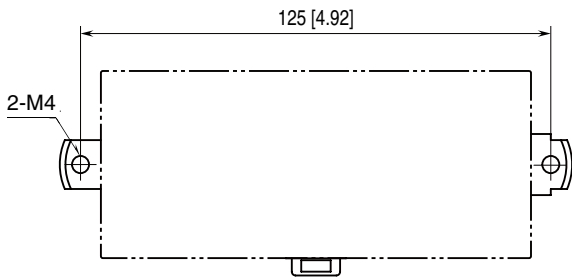

## DATA ALLOCATION

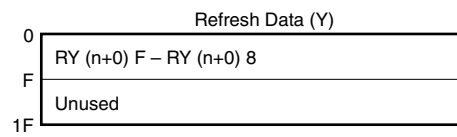
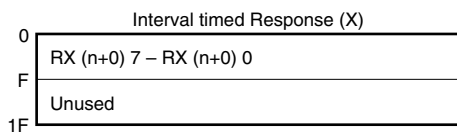

## I/O DATA DESCRIPTIONS

### ■ DISCRETE I/O

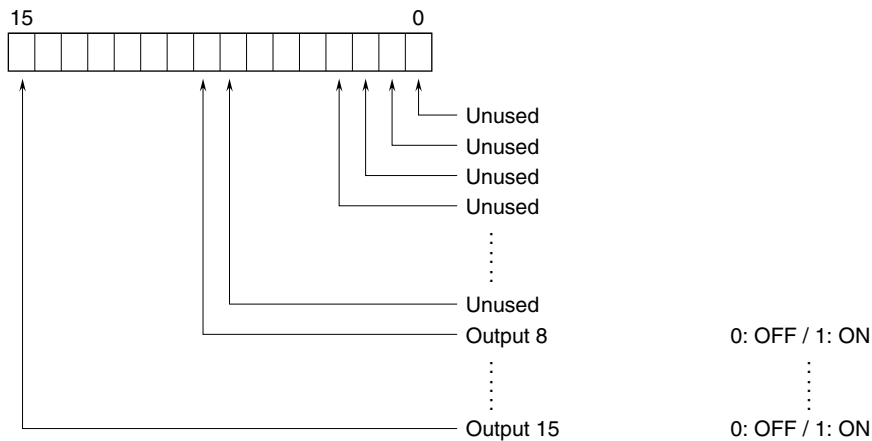
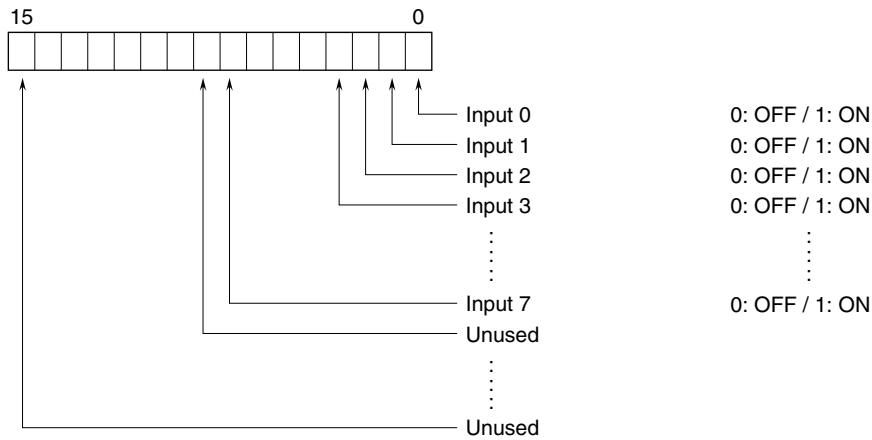

## COMMUNICATION CABLE WIRING

### ■ MASTER CONNECTION

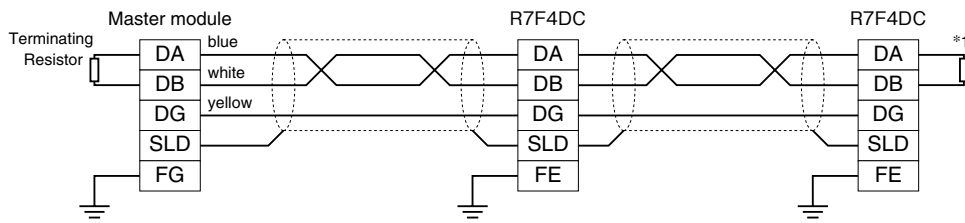

\*1. Turn on the terminator DIP switch to activate the internal terminating resistor.