

CC-Link I/O MODULE

(NPN/PNP discrete input, 32 points, FCN connector)

MODEL R7F4HC-DA32-K

BEFORE USE

Thank you for choosing us. Before use, please check contents of the package you received as outlined below. If you have any problems or questions with the product, please contact our sales office or representatives.

■ PACKAGE INCLUDES:

Discrete input module.....(1)
DIN rail mouser slider.....(2)

■ MODEL NO.

Confirm Model No. marking on the product to be exactly what you ordered.

■ INSTRUCTION MANUAL

This manual describes necessary points of caution when you use this product, including installation, connection and basic maintenance procedures.

■ CSP+ file

CSP+ file is downloadable at our web site or CC-Link Partner Association's web site (<https://www.cc-link.org>).

POINTS OF CAUTION

■ CONFORMITY WITH EU DIRECTIVES

- The equipment must be mounted inside the instrument panel of a metal enclosure.
- The actual installation environments such as panel configurations, connected devices, connected wires, may affect the protection level of this unit when it is integrated in a panel system. The user may have to review the CE requirements in regard to the whole system and employ additional protective measures* to ensure the CE conformity.

* For example, installation of noise filters and clamp filters for the power source, input and output connected to the unit, etc.

■ POWER INPUT RATING & OPERATIONAL RANGE

- Locate the power input rating marked on the product and confirm its operational range as indicated below:
24V DC rating: 24V \pm 10%, \leq 40 mA

■ GENERAL PRECAUTIONS

- Before you remove the unit or mount it, turn off the power supply and input signal for safety.
- Before you remove the connector or mount it, make sure to turn off the power supply and input signal for safety.
- DO NOT set the switches on the module while the power is supplied. The switches are used only for maintenance without the power.

■ ENVIRONMENT

- Indoor use.
- When heavy dust or metal particles are present in the air, install the unit inside proper housing with sufficient ventilation.
- Do not install the unit where it is subjected to continuous vibration. Do not subject the unit to physical impact.
- Environmental temperature must be within -10 to +55°C (14 to 131°F) with relative humidity within 30 to 90% RH in order to ensure adequate life span and operation.
- With vertical mounting, for heat dissipation leave at least 10 mm (.39 in.) at the both side of the unit.

■ WIRING

- Do not install cables close to noise sources (relay drive cable, high frequency line, etc.).
- Do not bind these cables together with those in which noises are present. Do not install them in the same duct.

■ AND

- The unit is designed to function as soon as power is supplied, however, a warm up for 10 minutes is required for satisfying complete performance described in the data sheet.

COMPONENT IDENTIFICATION

■ TOP VIEW

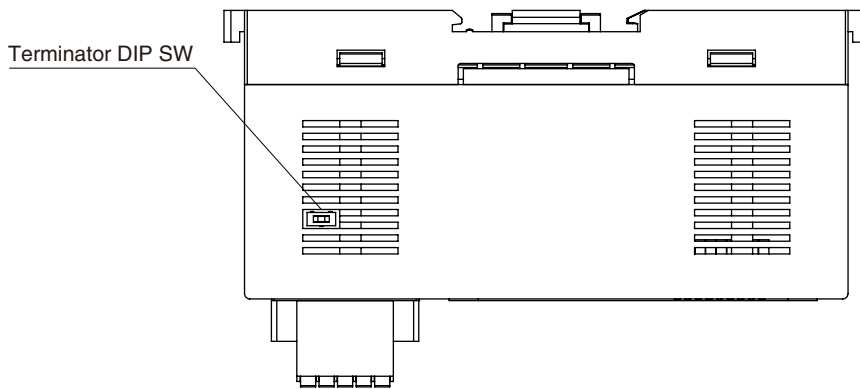

■ FRONT VIEW

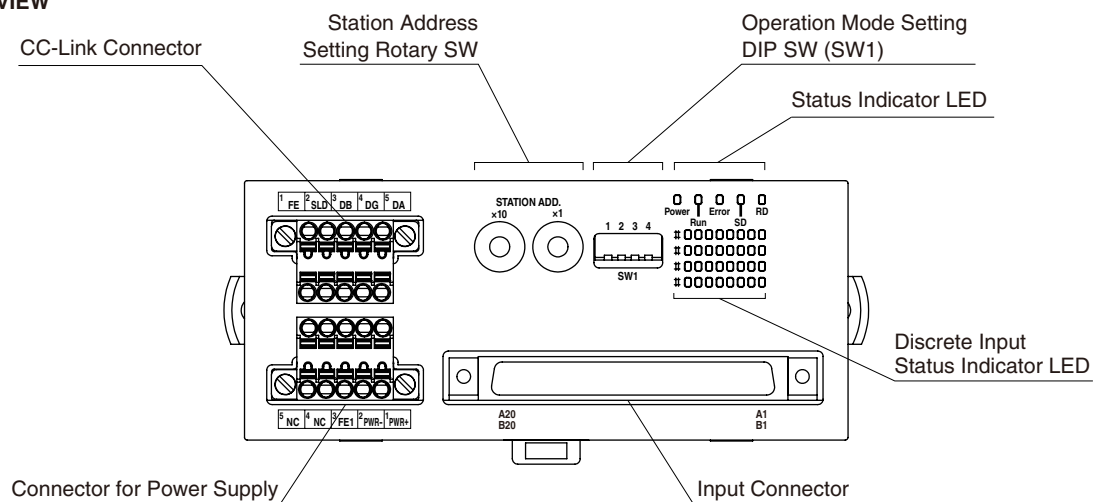

■ STATUS INDICATOR LED

ID	STATUS	COLOR	FUNCTION
Power	ON	Green	Internal 5V power is in normal status.
Run	ON	Green	The refresh data is received normally
Error	ON	Red	The received data is abnormal.
SD	ON	Green	The module is transmitting.
RD	ON	Green	The module is receiving.

■ DISCRETE INPUT STATUS INDICATOR LED

Green LED shows the input status.

ON : LED ON
OFF : LED OFF

■ STATION ADDRESS

The left switch determines the tenth place digit, while the right one does the ones place digit of the station address (1 - 64).

(Factory setting: 00)

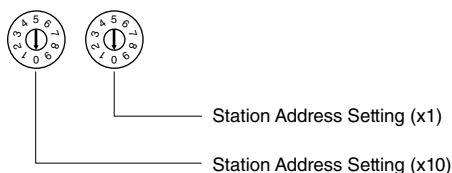

■ OPERATING MODE

(*) Factory setting

• Read Rate (SW1-1, 1-2, 1-3)

BAUD RATE	SW1		
	1	2	3
0:156 kbps (*)	OFF	OFF	OFF
1:625 kbps	ON	OFF	OFF
2:2.5 Mbps	OFF	ON	OFF
3:5 Mbps	ON	ON	OFF
4:10 Mbps	OFF	OFF	ON

Note: Be sure to set unused SW1-4 to OFF.

■ TERMINATING RESISTOR

To use the terminating resistor, turn the switch ON, and OFF to invalidate. (Factory setting OFF)

■CC-Link, POWER SUPPLY ASSIGNMENT

Unit side connector: MC1,5/5-GF-3,5 (Phoenix Contact)

Cable side connector: TFMC1,5/5-STF-3,5 (Phoenix Contact)

Applicable wire size: 0.2 - 1.5mm², stripped length 10mm

A10,25-10YE 0.25mm² (Phoenix Contact)

A0,34-10TQ 0.34mm² (Phoenix Contact)

A10,5-10WH 0.5mm² (Phoenix Contact)

A10,75-10GY 0.75mm² (Phoenix Contact)

A11-10 1.0mm² (Phoenix Contact)

A11,5-10 1.5mm² (Phoenix Contact)

· CC-Link

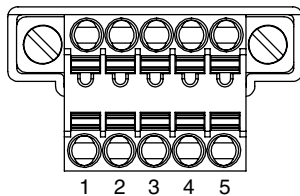

NO.	ID	FUNCTION
1	FE	Functional earth
2	SLD	Shield
3	DB	DB (white)
4	DG	DG (yellow)
5	DA	DA (blue)

· POWER SUPPLY

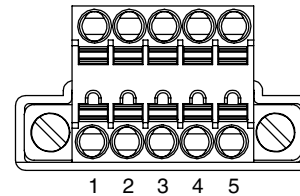

NO.	ID	FUNCTION
1	PWR+	Power supply +
2	PWR-	Power supply -
3	FE1	Grounding
4	NC	Unused
5	NC	Unused

Note: The numbers marked on the connector have no relationship to the pin number of the unit.

Wire according to the instruction manual of the unit.

■ INPUT, SENSOR EXC. ASSIGNMENT

Unit side connector: N365P040AU (OTAX) (FCN-365P040-AU (Fujitsu)...discontinued)

Cable side connector: N36()J040AU(OTAX) (FCN-36()J040-AU (Fujitsu)...discontinued)

(The cable connector is not included in the package. Specify wire size instead of (); refer to the specifications of the product)



PIN NO.	ID	FUNCTION	PIN NO.	ID	FUNCTION
A1	NC	Unused	B1	COM	Common (exc. supply)
A2	NC	Unused	B2	COM	Common (exc. supply)
A3	NC	Unused	B3	NC	Unused
A4	NC	Unused	B4	NC	Unused
A5	X31	Input 31	B5	X15	Input 15
A6	X30	Input 30	B6	X14	Input 14
A7	X29	Input 29	B7	X13	Input 13
A8	X28	Input 28	B8	X12	Input 12
A9	X27	Input 27	B9	X11	Input 11
A10	X26	Input 26	B10	X10	Input 10
A11	X25	Input 25	B11	X9	Input 9
A12	X24	Input 24	B12	X8	Input 8
A13	X23	Input 23	B13	X7	Input 7
A14	X22	Input 22	B14	X6	Input 6
A15	X21	Input 21	B15	X5	Input 5
A16	X20	Input 20	B16	X4	Input 4
A17	X19	Input 19	B17	X3	Input 3
A18	X18	Input 18	B18	X2	Input 2
A19	X17	Input 17	B19	X1	Input 1
A20	X16	Input 16	B20	X0	Input 0

MOUNTING INSTRUCTIONS

■ DIN RAIL MOUNTING (PARALLEL)

• Mounting

- A) Set the upper hook at the rear side of the unit on the DIN rail.
B) Push in the lower.

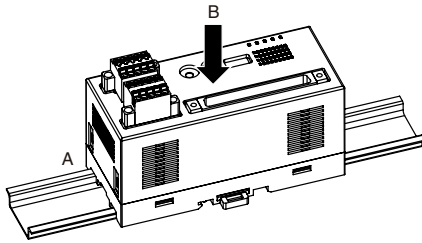

• Dismounting

- A) Push down the DIN rail mounter slider with tip of a minus screwdriver.
B) Pull the lower of the unit.
C) Remove the upper hook of the unit from the DIN rail.

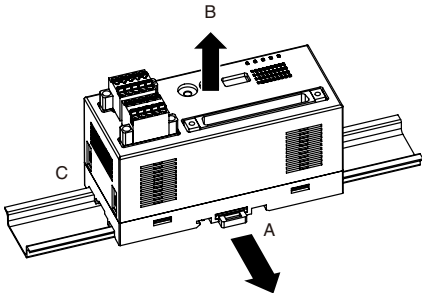

■ DIN RAIL MOUNTING (RIGHT ANGLE)

• Mounting

- A) Insert the longer DIN rail mounter slider until it clicks twice, as shown below.

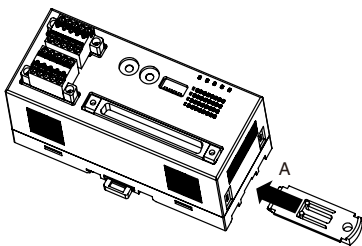

- B) Set the upper hook at the rear side of the unit on the DIN rail.
C) Push in the lower.

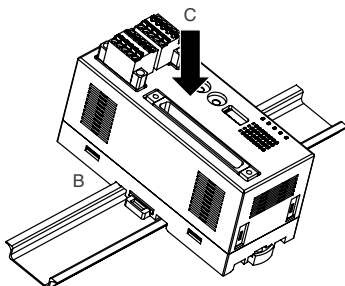

• Dismounting

- A) Push down the DIN rail mounter slider with tip of a minus screwdriver.
B) Pull the lower of the unit.
C) Remove the upper hook of the unit from the DIN rail.

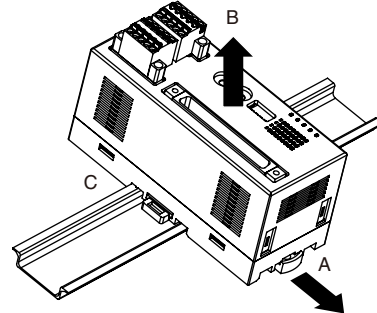

■ SURFACE MOUNTING

- A) Insert the two DIN rail mounter sliders until it clicks once, as shown below.

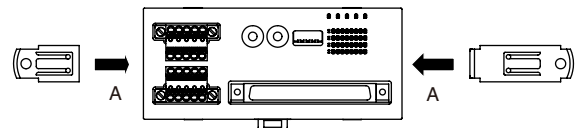

- B) Mount the unit with M4 screws referring the External Dimensions. (Torque: 1.4 N·m)

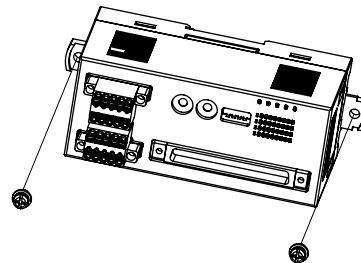

Note: leave at least 10 mm (.39 in.) at the both side of the unit.

TERMINAL CONNECTIONS

Connect the unit as in the diagram below.

EXTERNAL DIMENSIONS unit: mm [inch]

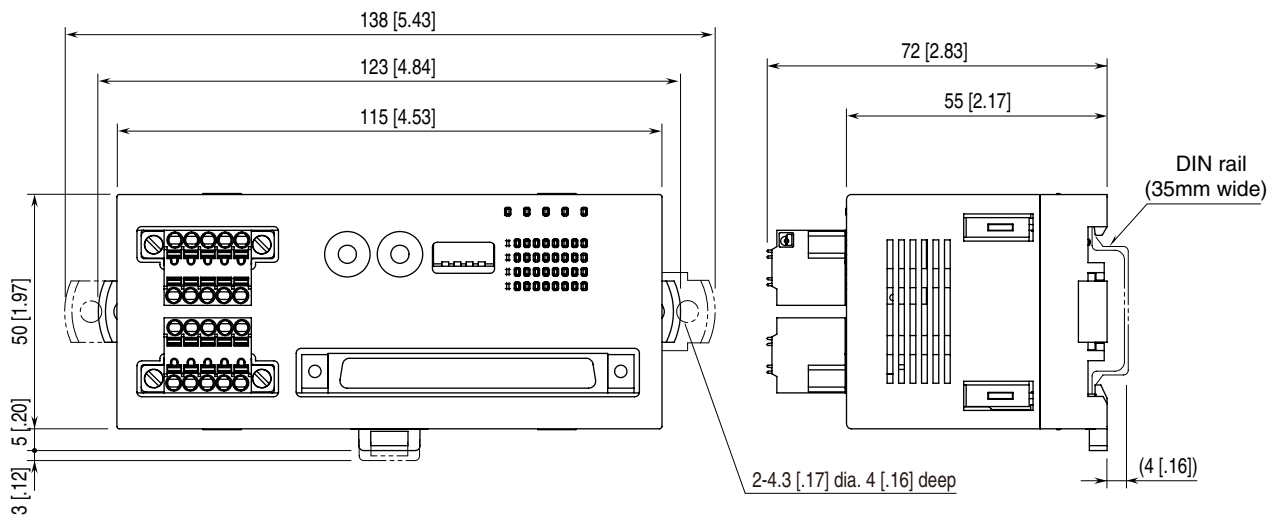

■ CONNECTION DIAGRAM

Note: In order to improve EMC performance, bond the FE1 terminal to ground.
 Caution: FE1 terminal is NOT a protective conductor terminal.

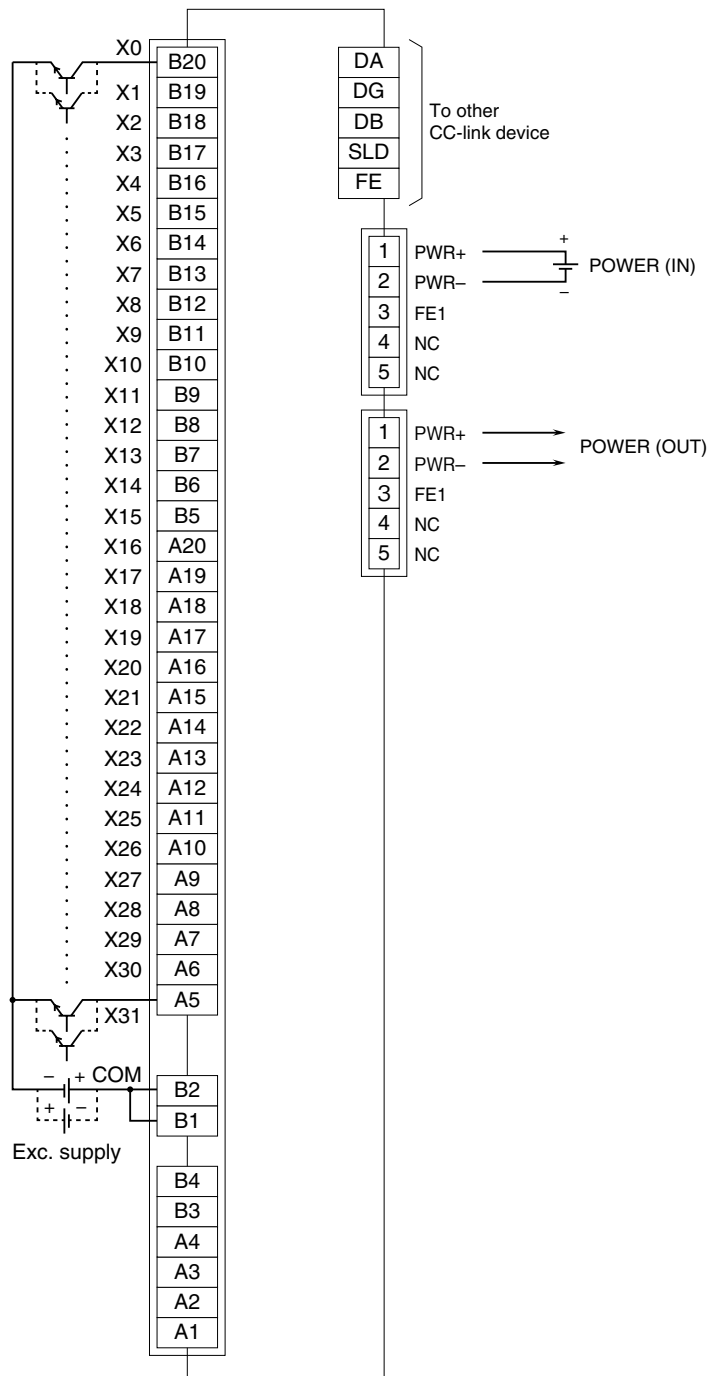

MOUNTING REQUIREMENTS unit: mm (inch)

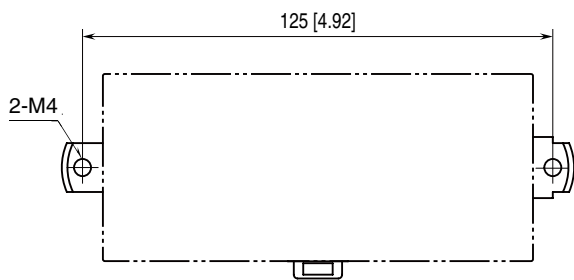

DATA ALLOCATION

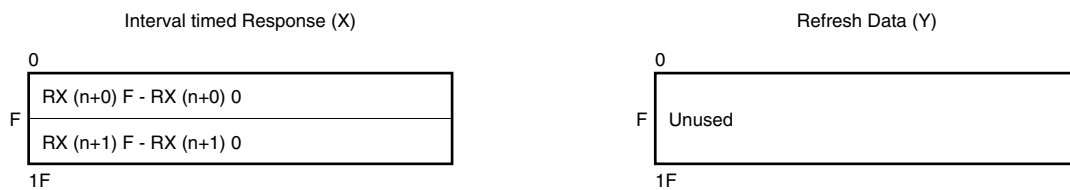

I/O DATA DESCRIPTIONS

DISCRETE INPUT

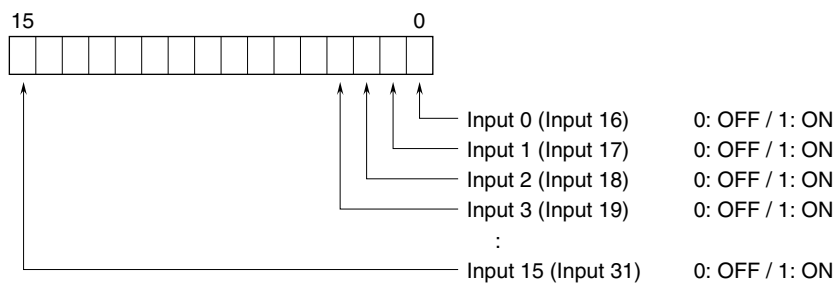

COMMUNICATION CABLE WIRING

MASTER CONNECTION

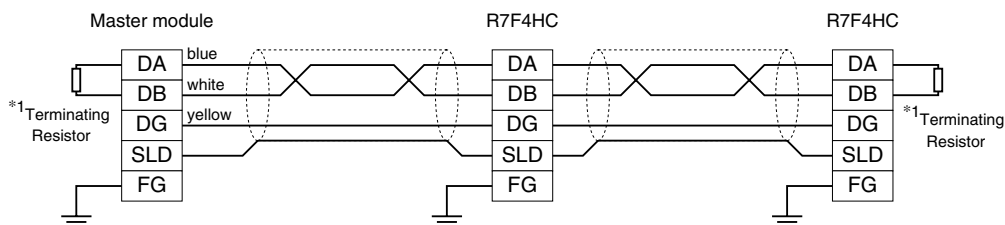

*1. Turn on the terminator DIP switch to activate the internal terminating resistor.