

**BEFORE USE ....**

Thank you for choosing us. Before use, please check contents of the package you received as outlined below.

If you have any problems or questions with the product, please contact our sales office or representatives.

**■ PACKAGE INCLUDES:**

Discrete output module.....(1)  
DIN rail mounter slider.....(2)

**■ MODEL NO.**

Confirm Model No. marking on the product to be exactly what you ordered.

**■ INSTRUCTION MANUAL**

This manual describes necessary points of caution when you use this product, including installation, connection and basic maintenance procedures.

**■ EDS FILE**

EDS files are downloadable at our web site.

**POINTS OF CAUTION****■ CONFORMITY WITH EU DIRECTIVES**

- The equipment must be mounted inside the instrument panel of a metal enclosure.
- The actual installation environments such as panel configurations, connected devices, connected wires, may affect the protection level of this unit when it is integrated in a panel system. The user may have to review the CE requirements in regard to the whole system and employ additional protective measures\* to ensure the CE conformity.

\* For example, installation of noise filters and clamp filters for the power source, input and output connected to the unit, etc.

**■ GENERAL PRECAUTIONS**

- Before you remove the unit or mount it, turn off the power supply and output signal for safety.
- Before you remove the terminal block or mount it, make sure to turn off the power supply and output signal for safety.
- DO NOT set the switches on the module while the power is supplied. The switches are used only for maintenance without the power.

**■ ENVIRONMENT**

- Indoor use.
- When heavy dust or metal particles are present in the air, install the unit inside proper housing with sufficient ventilation.
- Do not install the unit where it is subjected to continuous vibration. Do not subject the unit to physical impact.
- Environmental temperature must be within -10 to +55°C (14 to 131°F) with relative humidity within 30 to 90% RH in order to ensure adequate life span and operation.
- Observe at the minimum of 10 mm left and right the units for heat dissipation when mounting vertically.

**■ WIRING**

- Do not install cables close to noise sources (relay drive cable, high frequency line, etc.).
- Do not bind these cables together with those in which noises are present. Do not install them in the same duct.
- Be sure to close the terminal cover for safety.

**■ AND ....**

- The unit is designed to function as soon as power is supplied, however, a warm up for 10 minutes is required for satisfying complete performance described in the data sheet.

## COMPONENT IDENTIFICATION

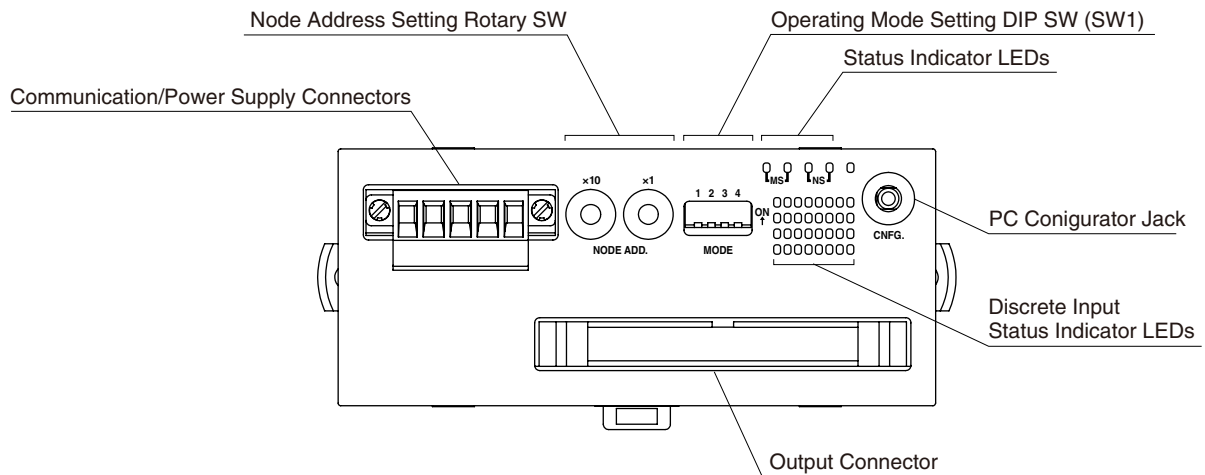

### ■ STATUS INDICATOR LED

ID	STATUS	COLOR	FUNCTION
MS	ON	Green	Normal operation
	Blinking	Green	Not set
	ON	Red	Critical failure
	Blinking	Red	Minor failure
	OFF	–	No power supply
NS	ON	Green	Connections are established
	Blinking	Green	Connections are not established
	ON	Red	Critical Link failure
	Blinking	Red	Minor Link failure
	OFF	–	No power supply

### ■ DISCRETE INPUT STATUS INDICATOR LED

LED green indicators shows the signal status.

ON : LED ON

OFF : LED OFF

### ■ NODE ADDRESS

The left switch determines the tenth place digit, while the right switch does the ones place digit of the address.

Address is selected between 0 to 63.

(Factory setting: 00)

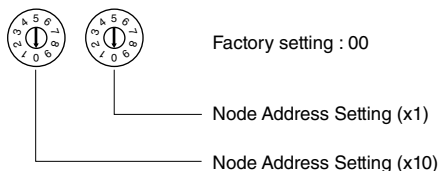

### ■ OPERATION MODE

(\*) Factory default setting

#### • BAUD RATE (SW1-1, 2)

Baud Rate is selected with the rotary switch.

BAUD RATE	SW1	
	1	2
125 kbps	OFF	OFF
250 kbps	ON	OFF
500 kbps	OFF	ON
Auto-tracking (*)	ON	ON

#### • STATUS DATA (SW1-3)

STATUS DATA	SW1
	3
Disable	OFF
Enable	ON

#### • OUTPUT AT THE LOSS OF COMMUNICATION (SW1-4)

Output at the loss of communication	SW1
	4
Hold the output (*) (maintains the last data received normally)	OFF
Reset the output (turned off)	ON

Note: The R7F4HD communicates in the baud rate setting detected at the startup with the switch set to the positions 0 (125 kbps), 1 (250 kbps) or 2 (500 kbps). For the settings auto-tracking, it analyzes the PLC's network to determine the baud rate on the network.

## ■ TERMINAL ASSIGNMENT

### • Communication/power supply Terminal Assignment

Unit side connector: MSTB2,5/5-GF-5,08AU (Phoenix Contact)

Cable side connector: MSTB2,5/5-STF-5,08AU (Phoenix Cont)

Applicable wire size: 0.2 - 2.5mm<sup>2</sup>

Stripped length: 7mm

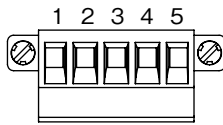

PIN NO.	COLOR	ID	FUNCTION
1	Red	V+	Communication/power supply (+)
2	White	CAN_H	Network data High
3	-	Drain	Shield
4	Blue	CAN_L	Network data Low
5	Black	V-	Communication/power supply (-)

### • Output Terminal Assignment

Applicable connector: XG4M-4030 (Omron)

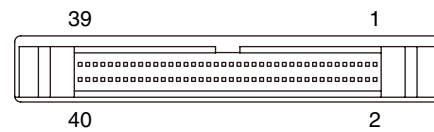

PIN No.	ID	FUNCTION	PIN No.	ID	FUNCTION
1	VS +	Exc. supply +	2	VS +	Exc. supply +
3	VS -	Exc. supply -	4	VS -	Exc. supply -
5	Y31	Output 31	6	Y23	Output 23
7	Y30	Output 30	8	Y22	Output 22
9	Y29	Output 29	10	Y21	Output 21
11	Y28	Output 28	12	Y20	Output 20
13	Y27	Output 27	14	Y19	Output 19
15	Y26	Output 26	16	Y18	Output 18
17	Y25	Output 25	18	Y17	Output 17
19	Y24	Output 24	20	Y16	Output 16
21	VS +	Exc. supply +	22	VS +	Exc. supply +
23	VS -	Exc. supply -	24	VS -	Exc. supply -
25	Y15	Output 15	26	Y7	Output 7
27	Y14	Output 14	28	Y6	Output 6
29	Y13	Output 13	30	Y5	Output 5
31	Y12	Output 12	32	Y4	Output 4
33	Y11	Output 11	34	Y3	Output 3
35	Y10	Output 10	36	Y2	Output 2
37	Y9	Output 9	38	Y1	Output 1
39	Y8	Output 8	40	Y0	Output 0

## MOUNTING INSTRUCTIONS

### ■ DIN RAIL MOUNTING (PARALLEL)

#### • Mounting

- 1) Set the upper hook at the rear side of the unit on the DIN rail.
- 2) Push the lower part in.

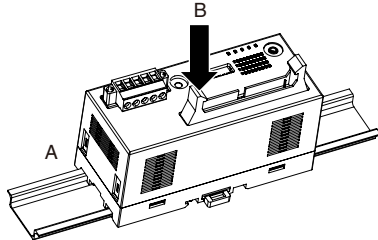

#### • Dismounting

- 1) Push down the DIN rail mouter slider with the tip of a flat-blade screwdriver.
- 2) Pull the lower part of the unit.
- 3) Remove the upper hook of the unit from the DIN rail.

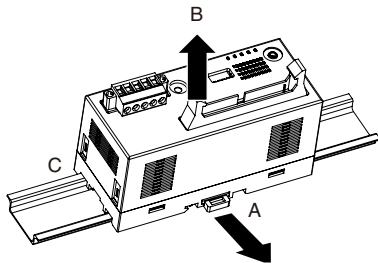

### ■ SURFACE MOUNTING

- 1) Insert the two DIN rail mouter sliders until it clicks once, as shown below.

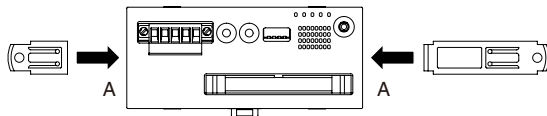

- 2) Mount the unit with M4 screws referring to the External Dimensions. (Torque: 1.4 N·m)

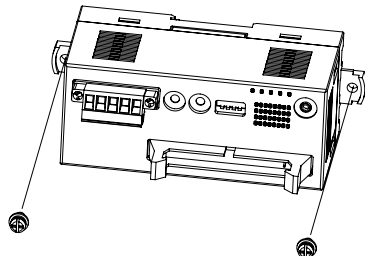

### ■ DIN RAIL MOUNTING (RIGHT ANGLE)

#### • Mounting

- 1) Insert the longer DIN rail mouter slider until it clicks twice, as shown below.

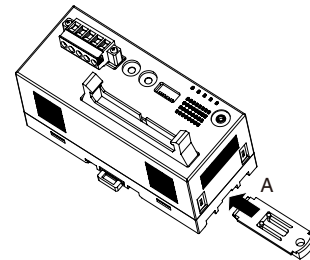

- 2) Set the upper hook at the rear side of the unit on the DIN rail.
- 3) Push the lower part in.

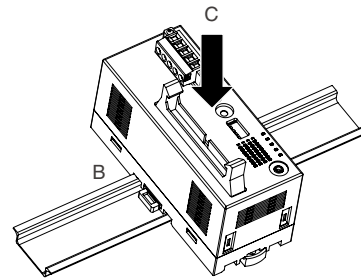

#### • Dismounting

- 1) Push down the DIN rail mouter slider with the tip of a flat-blade screwdriver.
- 2) Pull the lower part of the unit.
- 3) Remove the upper hook of the unit from the DIN rail.

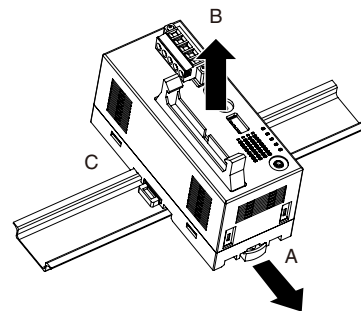

## TERMINAL CONNECTIONS

Connect the unit as in the diagram below.

### EXTERNAL DIMENSIONS unit: mm [inch]

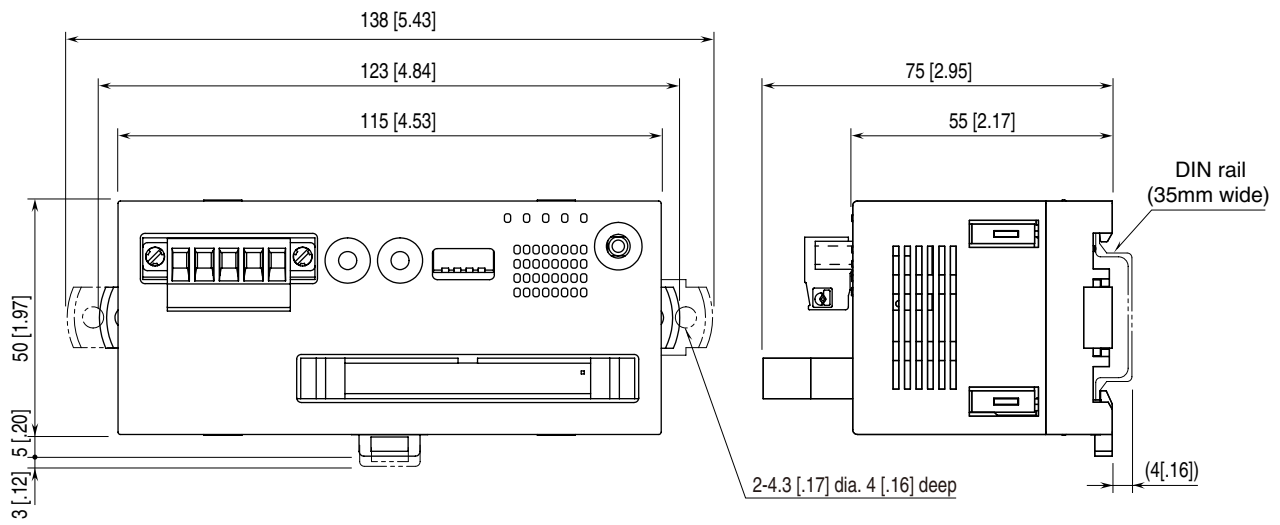

■ CONNECTION DIAGRAM

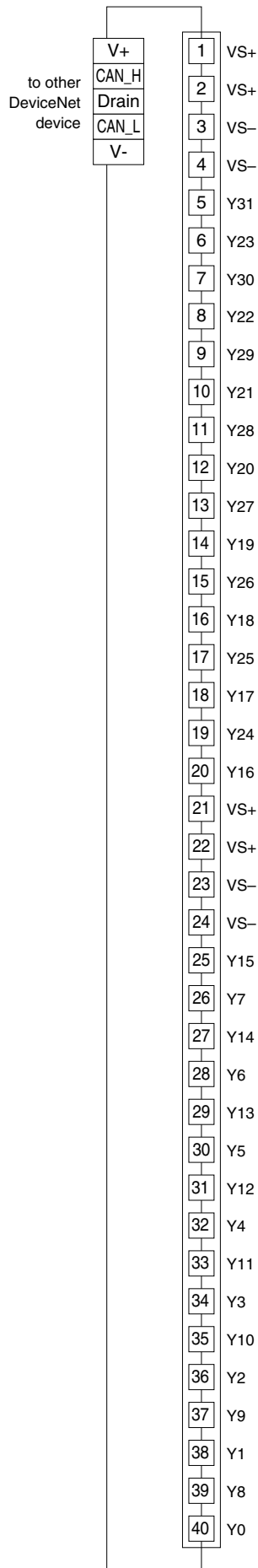

■ Output Connection Example

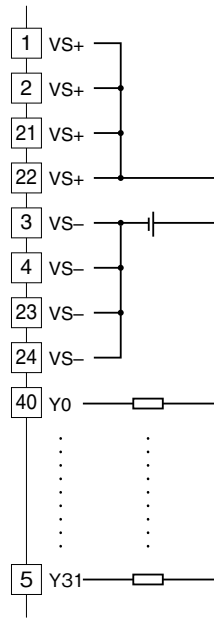

## MOUNTING REQUIREMENTS unit: mm [inch]

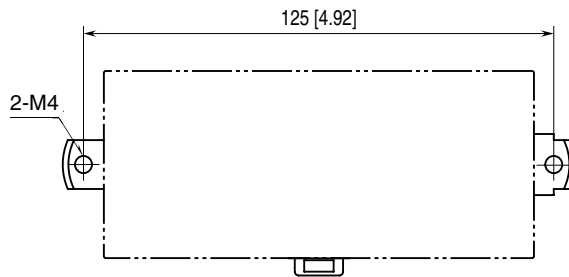

## PC CONFIGURATOR

The following parameter items can be configured with the PC configurator software (model: R7CFG). Refer to the users manual of the software for detailed operations.

### ■ INTERFACE SETTING

PARAMETER	SETTING RANGE	DEFAULT SETTING
Communication Timeout	0.0 – 32767 (0.1 sec.)	10 (0.1 sec.)

## DATA ALLOCATION

'Begin' address is determined by the R7F4HD's node address and the master setting.

### ■ Without Status

Output data

None

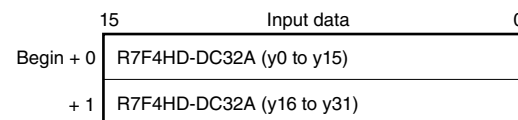

### ■ With Status

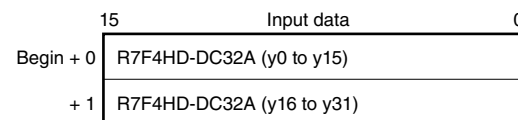
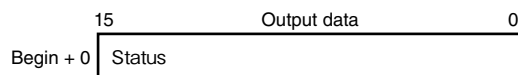

## I/O DATA DESCRIPTION

### ■ OUTPUT DATA

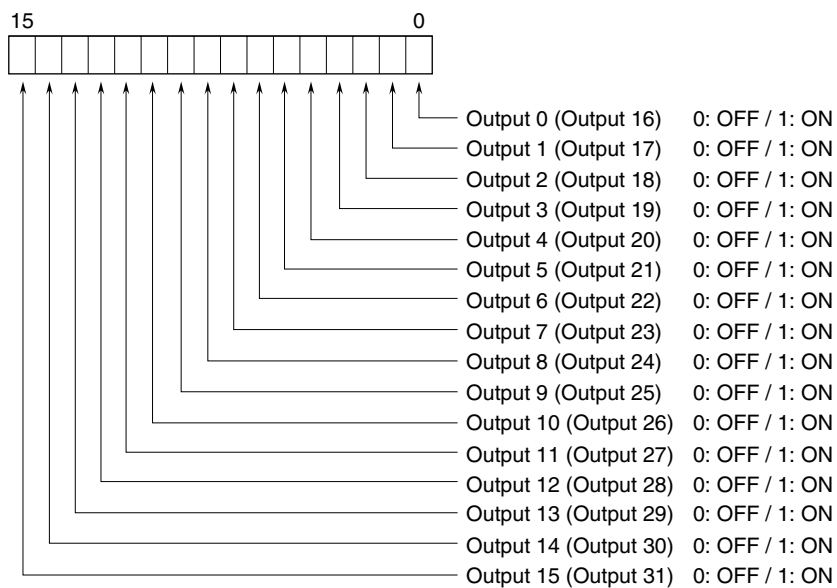

### ■ STATUS

Bit 8 - 10: Shows the power supply status.

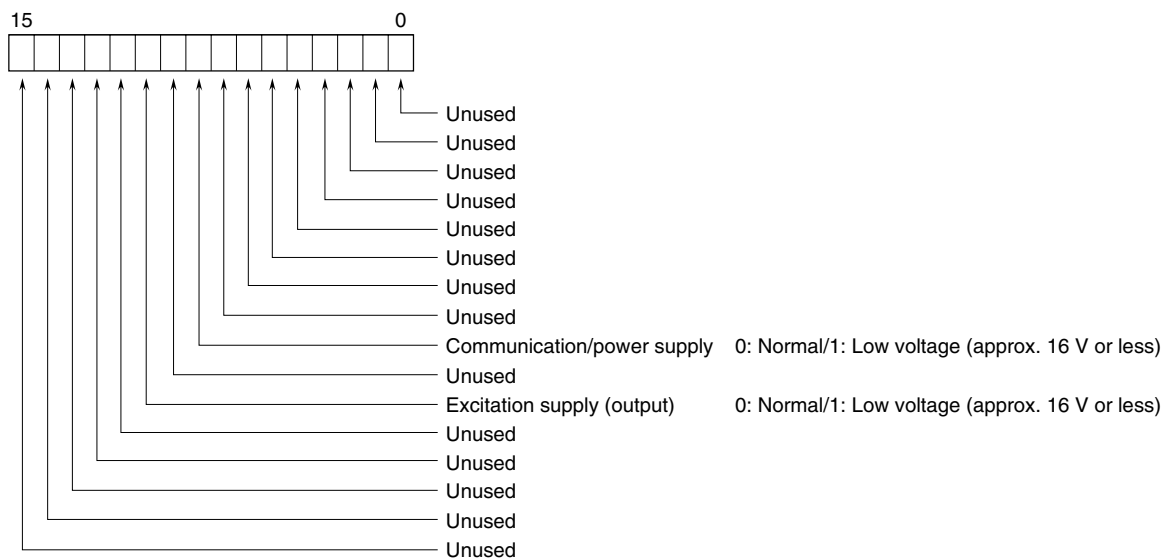



## TRANSMISSION DATA DESCRIPTIONS

### ■ I/O DATA

(Unit: word)

MODEL	OUTPUT DATA* <sup>1</sup> (R7F4HD to master)	INPUT DATA * <sup>2</sup> (Master to R7F4HD)
R7F4HD-DC32A	1	0

### ■ STATUS

Turn SW1-3 to ON to include the status signal in the transmission data.

For details, refer to "STATUS in I/O DATA DESCRIPTIONS"

(Unit: word)

STATUS	OUTPUT DATA* <sup>1</sup> (R7F4HD to master)	INPUT DATA * <sup>2</sup> (Master to R7F4HD)
Enabled	1	0
Disabled	0	0

\*1. Output Data means those sent to the master.

\*2. Input Data means those received from the master.