

**MECHATROLINK I/O MODULE**  
(high-speed DC voltage/current input, 4 points, isolated,  
screw terminal block, MECHATROLINK-I/-II use)MODEL **R7G4HML-6-SVF4****BEFORE USE ....**

Thank you for choosing us. Before use, please check contents of the package you received as outlined below.

If you have any problems or questions with the product, please contact our sales office or representatives.

**■ PACKAGE INCLUDES:**

High-speed DC voltage/current input module.....(1)  
DIN rail mounter slider .....(2)

**■ MODEL NO.**

Confirm Model No. marking on the product to be exactly what you ordered.

**■ INSTRUCTION MANUAL**

This manual describes necessary points of caution when you use this product, including installation, connection and basic maintenance procedures.

**POINTS OF CAUTION****■ CONFORMITY WITH EU DIRECTIVES**

- The equipment must be mounted inside the instrument panel of a metal enclosure.
- The actual installation environments such as panel configurations, connected devices, connected wires, may affect the protection level of this unit when it is integrated in a panel system. The user may have to review the CE requirements in regard to the whole system and employ additional protective measures to ensure the CE conformity.

**■ POWER INPUT RATING & OPERATIONAL RANGE**

- Locate the power input rating marked on the product and confirm its operational range as indicated below:  
24V DC rating: 24V  $\pm$ 10%, approx. 70mA

**■ GENERAL PRECAUTIONS**

- Before you remove the unit or mount it, turn off the power supply and input signal for safety.
- Before you remove the terminal block or mount it, make sure to turn off the power supply and input signal for safety.
- DO NOT set the switches on the module while the power is supplied. The switches are used only for maintenance without the power.

**■ ENVIRONMENT**

- Indoor use.
- When heavy dust or metal particles are present in the air, install the unit inside proper housing with sufficient ventilation.
- Do not install the unit where it is subjected to continuous vibration. Do not subject the unit to physical impact.
- Environmental temperature must be within 0 to 55°C (32 to 131°F) with relative humidity within 30 to 90% RH in order to ensure adequate life span and operation.

**■ WIRING**

- Do not install cables close to noise sources (relay drive cable, high frequency line, etc.).
- Do not bind these cables together with those in which noises are present. Do not install them in the same duct.
- Be sure to close the terminal cover for safety.

**■ AND ....**

- The unit is designed to function as soon as power is supplied, however, a warm up for 10 minutes is required for satisfying complete performance described in the data sheet.

## COMPONENT IDENTIFICATION

### ■ TOP VIEW

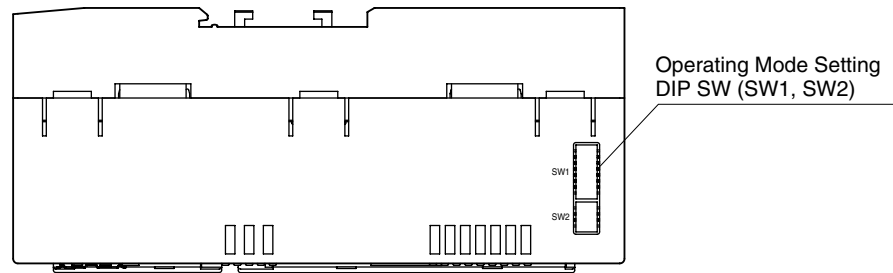

### ■ FRONT VIEW

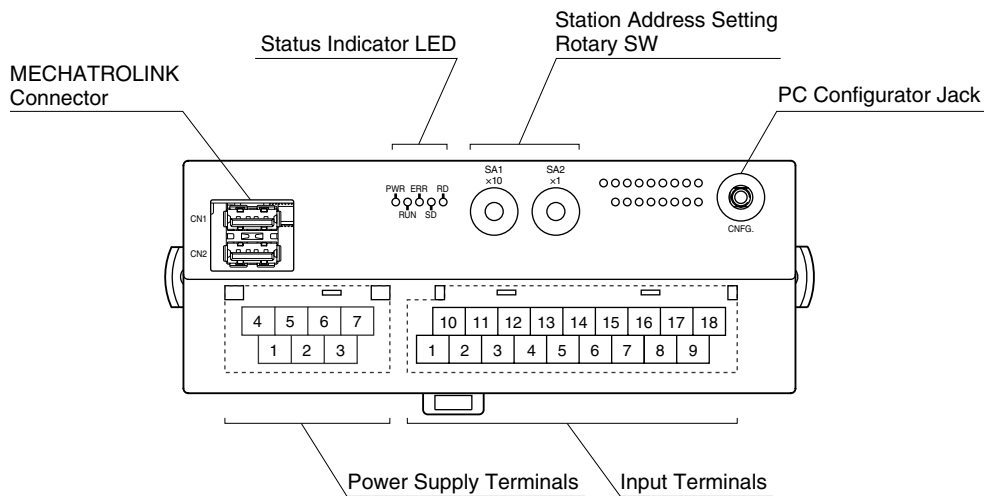

### ■ STATUS INDICATOR LED

ID	COLOR	FUNCTION
PWR	Green	Turns on when the internal power is supplied normally.
RUN	Green	Turns on in normal communications conditions.
ERR	Red	Turns on in no communication or setting error.
SD	Green	Turns on when the module is transmitting.
RD	Green	Turns on when the module is receiving.

### ■ STATION ADDRESS

Station Address is selected between 60H and 7FH (Intelligent I/O) in hexadecimal.

The left switch and the right switch determine the MSD and the LSD of the address, respectively.

(Factory setting: 61H)

Certain numbers may not be selectable depending on the master types.

Refer to the instruction manual of the master unit for detail.

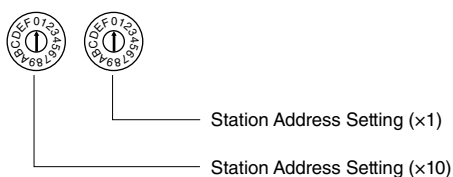

### ■ OPERATING MODE

(\*) Factory setting

#### • Input range: SW1-5, 1-6, 1-7, 1-8

SW1-5	SW1-6	SW1-7	SW1-8	INPUT RANGE
OFF	OFF	OFF	OFF	-10 – +10V DC (*)
ON	OFF	OFF	OFF	-5 – +5V DC
OFF	ON	OFF	OFF	-1 – +1V DC
ON	ON	OFF	OFF	0 – 10V DC
OFF	OFF	ON	OFF	0 – 5V DC
ON	OFF	ON	OFF	1 – 5V DC
OFF	ON	ON	OFF	0 – 1V DC
ON	ON	ON	OFF	-0.5 – +0.5V DC
ON	OFF	OFF	ON	-20 – +20mA DC
OFF	ON	OFF	ON	4 – 20mA DC
ON	ON	OFF	ON	0 – 20mA DC
ON	ON	ON	ON	Configurable via R7CFG

#### • MECHATROLINK mode: SW2-1, 2-2

SW2-1	SW2-2	MECHATROLINK MODE
OFF	OFF	MECHATROLINK-II (17 byte mode) (*)
ON	OFF	MECHATROLINK-II (32 byte mode)
OFF	ON	MECHATROLINK-I (17 byte mode)

Note: Be sure to set unused SW1-1 through 1-4, SW2-3 and 2-4 to OFF.

## POWER SUPPLY TERMINAL ASSIGNMENT

4	5	6	7
NC	NC	+24V	0V
1	2	3	
NC	NC	FE	

1. NC	-
2. NC	-
3. FE	Functional earth
4. NC	-
5. NC	-
6. +24V	Power supply (24V DC)
7. 0V	Power supply (0V)

## INPUT TERMINAL ASSIGNMENT

10	11	12	13	14	15	16	17	18
VL0	I0	VL1	I1	NC	VL2	I2	VL3	I3
1	2	3	4	5	6	7	8	9
VH0	COM0	VH1	COM1	NC	VH2	COM2	VH3	COM3

NO.	ID	FUNCTION	NO.	ID	FUNCTION
1	VH0	Wide span volt. 0	10	VL0	Narrow span volt. 0
2	COM0	Common 0	11	I0	Current range 0
3	VH1	Wide span volt. 1	12	VL1	Narrow span volt. 1
4	COM1	Common 1	13	I1	Current range 1
5	NC	No connection	14	NC	No connection
6	VH2	Wide span volt. 2	15	VL2	Narrow span volt. 2
7	COM2	Common 2	16	I2	Current range 2
8	VH3	Wide span volt. 3	17	VL3	Narrow span volt. 3
9	COM3	Common 3	18	I3	Current range 3

### INPUT RANGE

- **Wide span:** -10 – +10V DC, -5 – +5V DC, 0 – 10V DC, 0 – 5V DC, 1 – 5V DC
- **Narrow span:** -1 – +1V DC, 0 – 1V DC, -0.5 – +0.5V DC
- **Current input:** -20 – +20mA DC, 0 – 20mA DC, 4 – 20mA DC

## PC CONFIGURATOR

The following parameter items can be set with using PC Configurator Software (model: R7CFG).

Refer to the users manual for the R7CFG for detailed operation of the software program.

### CHANNEL INDIVIDUAL SETTING

PARAMETER	SETTING RANGE	DEFAULT SETTING
Validating/ Invalidating	Valid Invalid	Valid
Input range	-10 to +10V DC -5 to +5V DC -1 to +1V DC 0 to 10V DC 0 to 5V DC 1 to 5V DC 0 to 1V DC -0.5 to +0.5V DC -20 to +20mA DC 0 to 20mA DC 4 to 20mA DC	-10 to +10V DC
Bias	-320.00 to +320.00 (%)	0.00 (%)
Gain	-3.2000 to +3.2000	1.0000
Zero scale	-32 000 to +32 000	0
Full scale	-32 000 to +32 000	10 000

### CHANNEL BATCH SETTING

PARAMETER	SETTING RANGE	DEFAULT SETTING
Averaging	1, 2, 4, 8, 16, 32, 64, 128, 256	1

## MOUNTING INSTRUCTIONS

### ■ DIN RAIL MOUNTING (PARALLEL)

#### • Mounting

- 1) Set the upper hook at the rear side of the unit on the DIN rail.
- 2) Push in the lower.

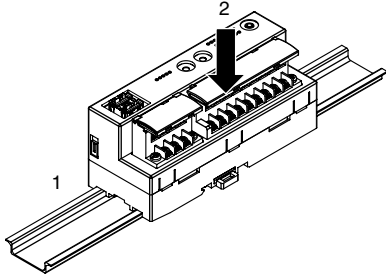

#### • Dismounting

- 1) Push down the DIN rail mounter slider with tip of a minus screwdriver.
- 2) Pull the lower of the unit.
- 3) Remove the upper hook of the unit from the DIN rail.

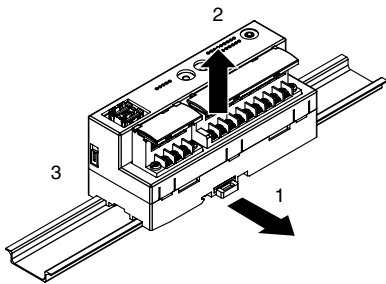

### ■ DIN RAIL MOUNTING (RIGHT ANGLE)

#### • Mounting

- 1) Insert the longer DIN rail mounter slider until it clicks twice, as shown below.

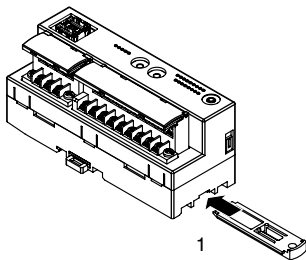

- 2) Set the upper hook at the rear side of the unit on the DIN rail.
- 3) Push in the lower.

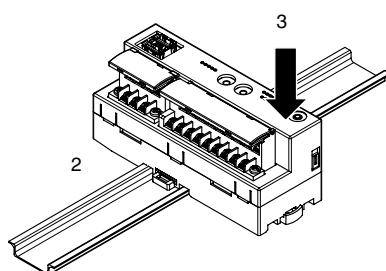

#### • Dismounting

- 1) Push down the DIN rail mounter slider with tip of a minus screwdriver.
- 2) Pull the lower of the unit.
- 3) Remove the upper hook of the unit from the DIN rail.

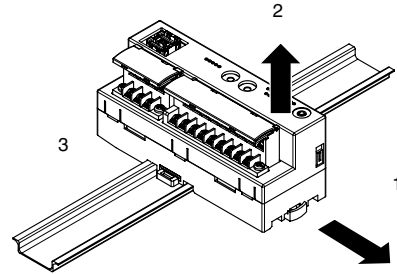

### ■ SURFACE MOUNTING

- 1) Insert the two DIN rail mounter sliders until it clicks once, as shown below.

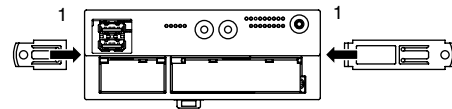

- 2) Mount the unit with M4 screws referring the External Dimensions. (Torque: 1.4 N·m)

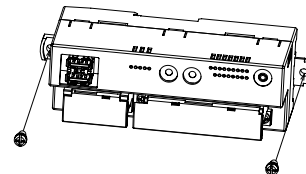

# TERMINAL CONNECTIONS

Connect the unit as in the diagram below.

## EXTERNAL DIMENSIONS unit: mm (inch)

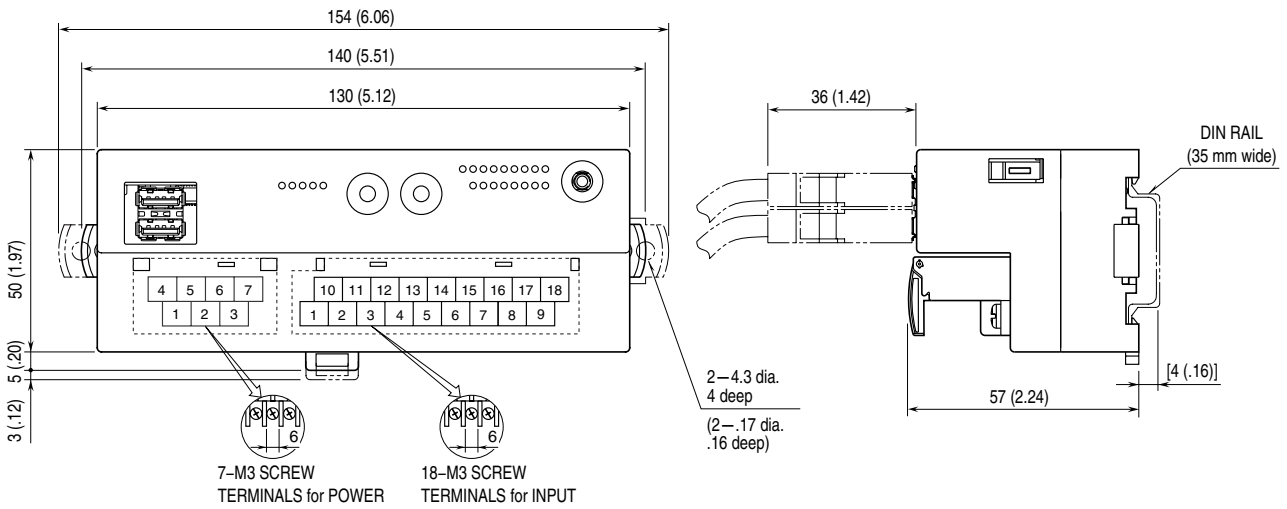

## CONNECTION DIAGRAM

Note: In order to improve EMC performance, bond the FE terminal to ground.  
 Caution: FE terminal is NOT a protective conductor terminal.

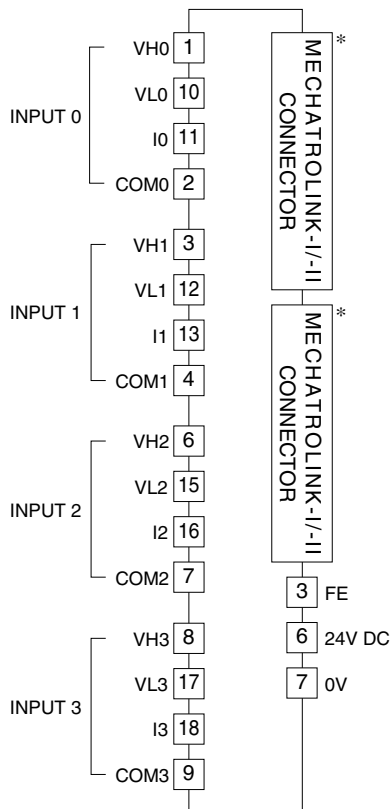

## INPUT CONNECTION EXAMPLES

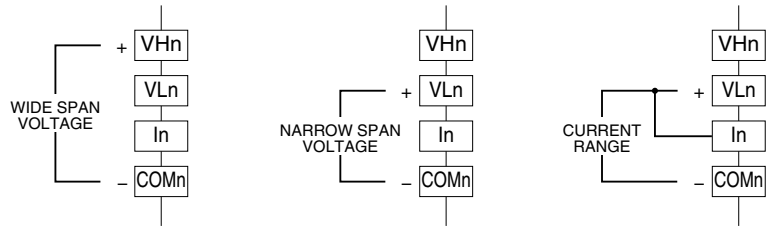

Note: Be sure VLn and In terminals are cross-wired at DC current input.  
 \* MECHATROLINK connectors are internally connected. The network cable can be connected to either one.

## MOUNTING REQUIREMENTS unit: mm (inch)

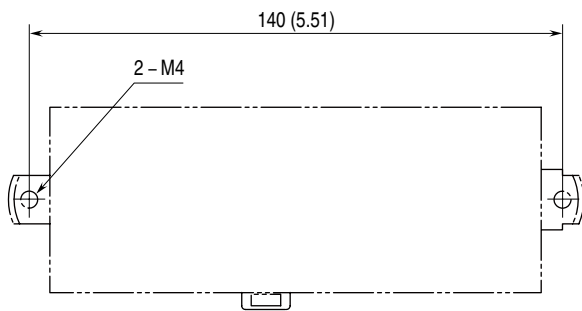

## WIRING INSTRUCTIONS

### ■ TORQUE

Wiring screw for separable terminal: 0.5 N·m  
 Fixing screw for separable terminal: 0.5 N·m

### ■ SOLDERLESS TERMINAL

Refer to the drawing below for recommended ring tongue terminal size. Spade tongue type is also applicable.  
 Applicable wire size: 0.25 to 1.65 mm<sup>2</sup> (AWG 22 to 16)  
 Recommended manufacturer: Japan Solderless Terminal MFG. Co., Ltd, Nichifu Co., Ltd

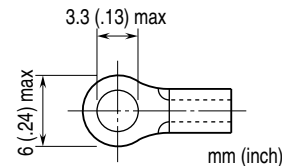

### ■ HOW TO UNMOUNT THE SEPARABLE TERMINAL

The separable terminal of the unit is 2 piece constructions. It is possible to remove the terminal by loosening two screws of terminal alternately.

## COMMUNICATION CABLE CONNECTIONS

### ■ MECHATROLINK CONNECTION

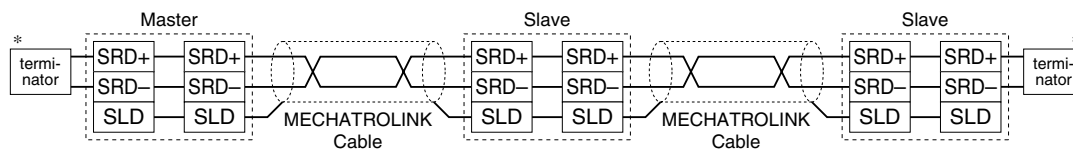

\*Terminator

Be sure to connect the terminating resistors to the unit at both ends of transmission line.

Use the terminating resistor dedicated for MECHATROLINK: Model JEPMC-W6022, Yaskawa Controls Co., Ltd.

Certain types of Master units may have incorporated terminating resistors. Consult the instruction manual for the Master.

## MECHATROLINK COMMUNICATION

### ■ MECHATROLINK-I

**Baud rate:** 4 Mbps

**Transmission distance:** 50 m max.

**Distance between stations:** 30 cm min.

**Transmission media:** MECHATROLINK cable (Model JEPMC-W6003-x-E, Yaskawa Controls Co., Ltd.)

**Max. number of slaves:** 15 (The maximum number of slaves might change depending on the master unit. Refer to the manual of the master unit)

**Transmission cycle:** 2 msec. (fixed)

**Data length:** 17 byte

### ■ MECHATROLINK-II

**Baud rate:** 10 Mbps

**Transmission distance:** 50 m max.

**Distance between stations:** 50 cm min.

**Transmission media:** MECHATROLINK cable (Model JEPMC-W6003-x-E, Yaskawa Controls Co., Ltd.)

**Max. number of slaves:** 30 (The maximum number of slaves might change depending on the master unit. Refer to the manual of the master unit)

**Transmission cycle:** 0.5 msec., 1 msec., 1.5 msec., 2 msec., 4 msec., 8 msec.

**Data length:** 17 bytes / 32 bytes selectable (Must choose identical data size for all stations on the same network)

## MECHATROLINK RELATED COMMANDS

### ■ MECHATROLINK DATA LINK LAYER COMMAND DESCRIPTIONS

The R7G4HML (Intelligent I/O) performs the connection-type communications according to MECHATROLINK protocol. The following tables explain Data Link Layer Commands supported by the R7G4HML.

#### • MDS Command (04H) Data Format

Byte	COMMAND	RESPONSE	REMARKS
0	MDS (04H)	S (0) (90H)	Message Data Search (MDS) Command: Read the ID from the slave station S (0): Response to MDS
1	0	ID1 (00H)	
2	0	ID2 (80H)	Intelligent I/O specified
3	0	0	
4	0	0	
5	0	0	
6	0	0	
7	0	0	
8	0	0	
9	0	0	
10	0	0	
11	0	0	
12	0	0	
13	0	0	
14	0	0	
15	0	0	
16	0	0	
17	0	0	Byte 17 through 31 are always 0 in the 32-byte mode.
:	:	:	These bytes are unavailable for MECHATROLINK-I, or MECHATROLINK-II in the
31	0	0	17-byte mode.

#### • CDRW Command (03H) Data Format

Byte	COMMAND	RESPONSE	REMARKS
0	CDRW (03H)	ACK (01H)	Cyclic Data Read/Write (CDRW) Command: Link transmission Acknowledge (ACK): Positive response to CDRW
1	CMD	RCMD	CMD: Application Layer Command RCMD: Response to Application Layer Command
2			Byte 2 through 16 depend upon the Application Layer Command type.
:			
16			
17			Byte 17 through 31 depend upon the Application Layer Command type.
:			These bytes are unavailable for MECHATROLINK-I, or MECHATROLINK-II in the
31			17-byte mode.

## MECHATROLINK APPLICATION LAYER COMMAND DESCRIPTIONS

The following tables explain Application Layer Commands supported by the R7G4HML (Intelligent I/O).

### • NOP Command (00H) Data Format

Byte	COMMAND	RESPONSE	REMARKS
0	CDRW (03H)	ACK (01H)	Cyclic Data Read/Write (CDRW) Command: Link transmission Acknowledge (ACK): Positive response to CDRW
1	NOP (00H)	NOP (00H)	No Operation (NOP) Command: Nothing is performed.
2	0	ALARM	Error code: See "MECHATROLINK APPLICATION LAYER DATA DESCRIPTIONS"
3	0	STATUS1	Status code: See "MECHATROLINK APPLICATION LAYER DATA DESCRIPTIONS"
4	0	STATUS2	Status code: See "MECHATROLINK APPLICATION LAYER DATA DESCRIPTIONS"
5	0	0	
6	0	0	
7	0	0	
8	0	0	
9	0	0	
10	0	0	
11	0	0	
12	0	0	
13	0	0	
14	0	0	
15	0	0	
16	0	0	
17	0	0	Byte 17 through 31 are always 0 in the 32-byte mode.
:	:	:	These bytes are unavailable for MECHATROLINK-I, or MECHATROLINK-II in the 17-byte mode.
31	0	0	

### • ID\_RD Command (03H) Data Format

Byte	COMMAND	RESPONSE	REMARKS
0	CDRW (03H)	ACK (01H)	Cyclic Data Read/Write (CDRW) Command: Link transmission Acknowledge (ACK): Positive response to CDRW
1	ID_RD (03H)	ID_RD (03H)	Read ID (ID_RD) Command: Read out the device ID
2	0	ALARM	Error code: See "MECHATROLINK APPLICATION LAYER DATA DESCRIPTIONS"
3	0	STATUS1	Status code: See "MECHATROLINK APPLICATION LAYER DATA DESCRIPTIONS"
4	0	STATUS2	Status code: See "MECHATROLINK APPLICATION LAYER DATA DESCRIPTIONS"
5	DEVICE_ CODE	DEVICE_ CODE	Specifies the device code 00H: Product's model number 0FH: Vendor code
6	OFFSET	OFFSET	Indicates where to start reading in the specified device ID
7	SIZE	SIZE	Number of byte counts to read
8	0	ID1	ASCII or binary data
9	0	ID2	ASCII or binary data
10	0	ID3	ASCII or binary data
11	0	ID4	ASCII or binary data
12	0	ID5	ASCII or binary data
13	0	ID6	ASCII or binary data
14	0	ID7	ASCII or binary data
15	0	ID8	ASCII or binary data
16	0	0	
17	0	0	Byte 17 through 31 are always 0 in the 32-byte mode.
:	:	:	These bytes are unavailable for MECHATROLINK-I, or MECHATROLINK-II in the 17-byte mode.
31	0	0	



## • CONNECT Command (0EH) Data Format

Byte	COMMAND	RESPONSE	REMARKS
0	CDRW (03H)	ACK (01H)	Cyclic Data Read/Write (CDRW) Command: Link transmission Acknowledge (ACK): Positive response to CDRW
1	CONNECT (0EH)	CONNECT (0EH)	Establish Connection (CONNECT) Command: Requests to establish connection to MECHATROLINK
2	0	ALARM	Error code: See "MECHATROLINK APPLICATION LAYER DATA DESCRIPTIONS"
3	0	STATUS1	Status code: See "MECHATROLINK APPLICATION LAYER DATA DESCRIPTIONS"
4	0	STATUS2	Status code: See "MECHATROLINK APPLICATION LAYER DATA DESCRIPTIONS"
5	VER	VER	Application Layer version number 10H: MECHATROLINK-I 21H: MECHATROLINK-II
6	COM_MODE	COM_MODE	Communication mode 00H: 17-byte mode 80H: 32-byte mode
7	COM_TIME	COM_TIME	Communication cycle (milliseconds) MECHATROLINK-I: Multiples of two (2) MECHATROLINK-II: Integral multiples of the transmission cycle
8	0	0	
9	0	0	
10	0	0	
11	0	0	
12	0	0	
13	0	0	
14	0	0	
15	0	0	
16	0	0	
17	0	0	Byte 17 through 31 are always 0 in the 32-byte mode.
:	:	:	These bytes are unavailable for MECHATROLINK-I, or MECHATROLINK-II in the
31	0	0	17-byte mode.

## • DISCONNECT Command (0FH) Data Format

Byte	COMMAND	RESPONSE	REMARKS
0	CDRW (03H)	ACK (01H)	Cyclic Data Read/Write (CDRW) Command: Link transmission Acknowledge (ACK): Positive response to CDRW
1	DISCONNECT (0FH)	DISCONNECT (0FH)	Release Connection (DISCONNECT) Command: Requests to release connection to MECHATROLINK
2	0	ALARM	Error code: See "MECHATROLINK APPLICATION LAYER DATA DESCRIPTIONS"
3	0	STATUS1	Status code: See "MECHATROLINK APPLICATION LAYER DATA DESCRIPTIONS"
4	0	STATUS2	Status code: See "MECHATROLINK APPLICATION LAYER DATA DESCRIPTIONS"
5	0	0	
6	0	0	
7	0	0	
8	0	0	
9	0	0	
10	0	0	
11	0	0	
12	0	0	
13	0	0	
14	0	0	
15	0	0	
16	0	0	
17	0	0	Byte 17 through 31 are always 0 in the 32-byte mode.
:	:	:	These bytes are unavailable for MECHATROLINK-I, or MECHATROLINK-II in the
31	0	0	17-byte mode.

• **DATA\_RWA Command (50H) Data Format**

Byte	COMMAND	RESPONSE	REMARKS
0	CDRW (03H)	ACK (01H)	Cyclic Data Read/Write (CDRW) Command: Link transmission Acknowledge (ACK): Positive response to CDRW
1	DATA_RWA (50H)	DATA_RWA (50H)	Data Read/Write_A (DATA_RWA) Command: Refreshes I/O data
2	0	ALARM	Error code: See "MECHATROLINK APPLICATION LAYER DATA DESCRIPTIONS"
3	0	STATUS1	Status code: See "MECHATROLINK APPLICATION LAYER DATA DESCRIPTIONS"
4	0	STATUS2	Status code: See "MECHATROLINK APPLICATION LAYER DATA DESCRIPTIONS"
5	0	CH0 IN LO	CH0 data Lower 8 bits
6	0	CH0 IN HI	CH0 data Upper 8 bits
7	0	CH1 IN LO	CH1 data Lower 8 bits
8	0	CH1 IN HI	CH1 data Upper 8 bits
9	0	CH2 IN LO	CH2 data Lower 8 bits
10	0	CH2 IN HI	CH2 data Upper 8 bits
11	0	CH3 IN LO	CH3 data Lower 8 bits
12	0	CH3 IN HI	CH3 data Upper 8 bits
13	0	0	Unused
14	0	0	
15	0	STATUS LO	Lower byte of R7G4HML status
16	0	STATUS HI	Upper byte of R7G4HML status
17	0	0	Byte 17 through 31 are always 0 in the 32-byte mode. These bytes are unavailable for MECHATROLINK-I, or MECHATROLINK-II in the 17-byte mode.
:	:	:	
31	0	0	

■ **MECHATROLINK APPLICATION LAYER DATA DESCRIPTIONS**

• **Alarm Error Codes**

Errors detected at the slave are set at ALARM in the response and sent to the master.

ERROR CODE	DESCRIPTION	ALARM LEVEL
00H	Normal status	----
01H	Invalid Command: Command is not supported.	Warning
02H	Command Not Allowed: Command execution conditions are not met.	Warning
03H	Invalid Data: Data in the command is not correct.	Warning
04H	Synchronization Error	Alarm

• **STATUS1**

Alarm/Warning classification and status information are set at STATUS1 according to the alarm level and sent to the master.

Bit	DEFINITION	DESCRIPTION
0	Alarm Bit	0 : Normal, 1 : Alarm
1	Warning Bit	0 : Normal, 1 : Warning
2	Command Ready Bit	0 : Command cannot be accepted (busy), 1 : Command can be accepted (ready)
3...7	Unused	----

• **STATUS2**

Reserved for future use.

• **STATUS**

R7G4HML status to be sent to the master.

See Status (Input Area Object) in the section "I/O DATA DESCRIPTION" on page 11.

## I/O DATA DESCRIPTION

### ■ ANALOG INPUT

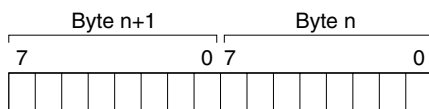

Data is represented in 16-bit binary. Negative value is represented in 2's complements.

### ■ STATUS

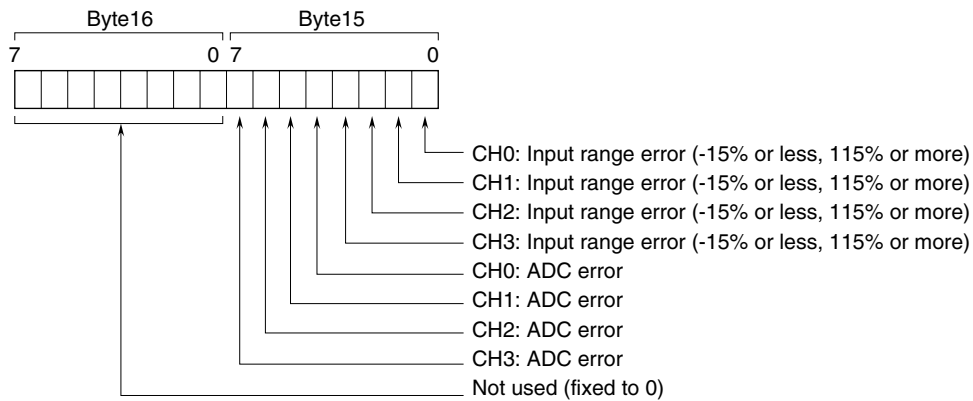

Input range error

0: normal, 1: error

ADC error (no response from ADC)

0: normal, 1: error