

BEFORE USE

Thank you for choosing us. Before use, please check contents of the package you received as outlined below.

If you have any problems or questions with the product, please contact our sales office or representatives.

■ PACKAGE INCLUDES:

Discrete I/O module(1)

■ MODEL NO.

Confirm Model No. marking on the product to be exactly what you ordered.

■ INSTRUCTION MANUAL

This manual describes necessary points of caution when you use this product, including installation, connection and basic maintenance procedures.

POINTS OF CAUTION**■ CONFORMITY WITH EU DIRECTIVE**

- Use dual-shield cables (Shinko Seisen Industry Model ZHY262 PBA) for the network. If it is not sufficient, use a ferrite core (Kitagawa Industries Model GRFC-13) for the network cable.
- The equipment must be mounted inside the instrument panel of a metal enclosure.
- The actual installation environments such as panel configurations, connected devices, connected wires, may affect the protection level of this unit when it is integrated in a panel system. The user may have to review the CE requirements in regard to the whole system and employ additional protective measures to ensure the CE conformity.

■ POWER INPUT RATING & OPERATIONAL RANGE

- Locate the power input rating marked on the product and confirm its operational range as indicated below:
24V DC rating: 24V \pm 10%, approx. 40mA

■ GENERAL PRECAUTIONS

- Before you remove the unit or mount it, turn off the power supply, input signal and output signal for safety.
- DO NOT set the switches on the module while the power is supplied. The switches are used only for maintenance without the power.

■ ENVIRONMENT

- Indoor use.
- When heavy dust or metal particles are present in the air, install the unit inside proper housing with sufficient ventilation.
- Do not install the unit where it is subjected to continuous vibration. Do not subject the unit to physical impact.
- Environmental temperature must be within -10 to +55°C (14 to 131°F) with relative humidity within 30 to 90% RH in order to ensure adequate life span and operation.

■ WIRING

- Do not install cables close to noise sources (relay drive cable, high frequency line, etc.).
- Do not bind these cables together with those in which noises are present. Do not install them in the same duct.

■ AND

- The unit is designed to function as soon as power is supplied, however, a warm up for 10 minutes is required for satisfying complete performance described in the data sheet.

COMPONENT IDENTIFICATION

■ SIDE VIEW

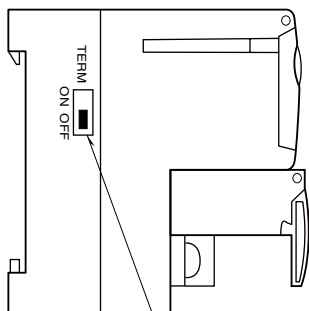

Terminating Resistor SW

■ FRONT VIEW

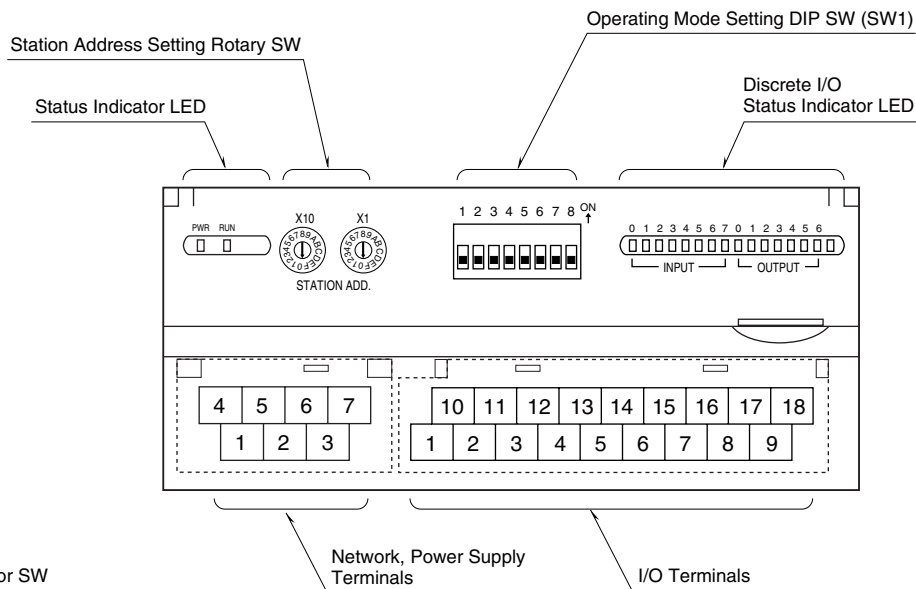

■ STATUS INDICATOR LED

ID	COLOR	FUNCTION
PWR	Green	Turns on when the internal 5V is supplied normally.
RUN	Green	Turns on when the refresh data is received normally.

■ DISCRETE I/O STATUS INDICATOR LED

LED indicators shows the signal status.
 ON : LED ON (red)
 OFF : LED OFF

■ STATION ADDRESS

The left switch determines the sixteenths place digit, while the right switch does the ones place digit of the address. (Range: 01H to 3FH)



Station Address Setting (x1)
 Station Address Setting (x16)

■ OPERATING MODE

(*) Factory setting

• Output at the loss of communication (SW1-7)

SW1-7	OUTPUT AT THE LOSS OF COMMUNICATION
OFF	Hold the output (*) (maintains the last data received normally)
ON	Reset the output (turned off)

• Transfer rate (SW1-8)

SW1-8	TRANSFER RATE
OFF	12 Mbps (*)
ON	6 Mbps

Note: Be sure to set unused SW1-1 through 1-6 to OFF.

■ TERMINATING RESISTOR

To use the terminating resistor, turn the switch ON, and OFF to invalidate. (Factory setting OFF)

■ NETWORK, POWER SUPPLY TERMINAL ASSIGNMENT

• Full-duplex communication

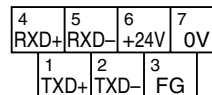

NO.	ID	FUNCTION, NOTES
1	TXD+	Network (slave, transmission +)
2	TXD-	Network (slave, transmission -)
3	FG	FG
4	RXD+	Network (master, transmission +)
5	RXD-	Network (master, transmission -)
6	+24V	Power input (24V DC)
7	0V	Power input (0V)

• Half-duplex communication

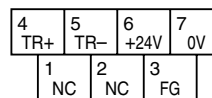

NO.	ID	FUNCTION, NOTES
1	NC	No connection
2	NC	No connection
3	FG	FG
4	TR+	Network
5	TR-	Network
6	+24V	Power input (24V DC)
7	0V	Power input (0V)

■ I/O TERMINAL ASSIGNMENT

10	11	12	13	14	15	16	17	18
+24V	X1	X3	X5	X7	Y1	Y3	Y5	Y7
1	2	3	4	5	6	7	8	9
COM	X0	X2	X4	X6	Y0	Y2	Y4	Y6

NO.	ID	FUNCTION	NO.	ID	FUNCTION
1	COM	Common	10	+24V	24V DC
2	X0	Input 0	11	X1	Input 1
3	X2	Input 2	12	X3	Input 3
4	X4	Input 4	13	X5	Input 5
5	X6	Input 6	14	X7	Input 7
6	Y0	Output 0	15	Y1	Output 1
7	Y2	Output 2	16	Y3	Output 3
8	Y4	Output 4	17	Y5	Output 5
9	Y6	Output 6	18	Y7	Output 7

TERMINAL CONNECTIONS

Connect the unit as in the diagram below.

■ EXTERNAL DIMENSIONS unit: mm (inch)

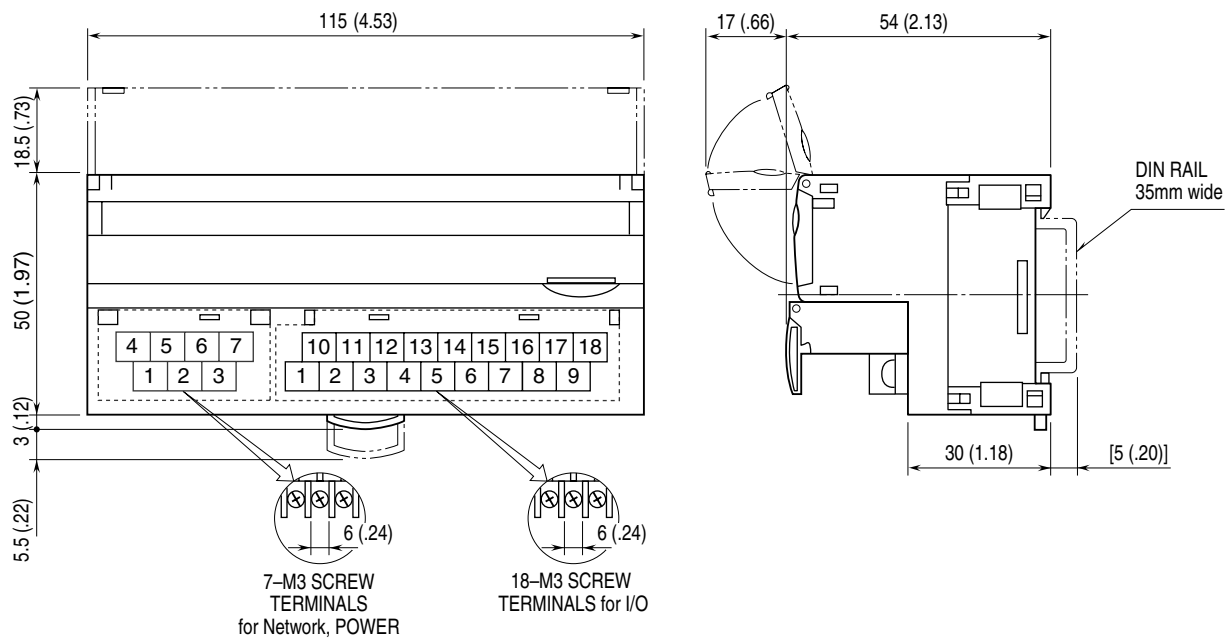

■ CONNECTION DIAGRAM

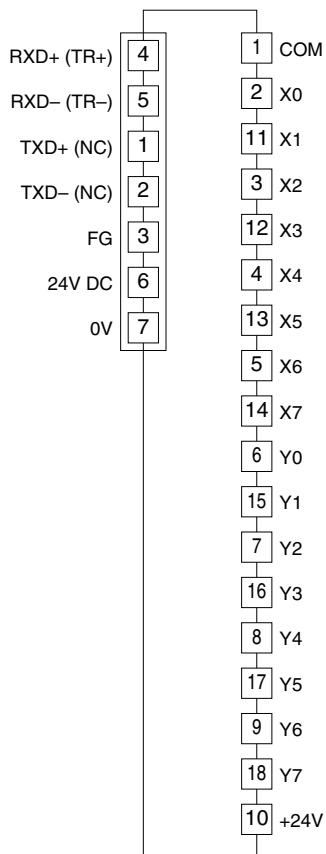

Note 1: Terminal numbers in parentheses are for half-duplex communication models.

Note 2: In order to improve EMC performance, bond the FG terminal to ground.

Caution: FG terminal is NOT a protective conductor terminal.

■ I/O Connection Example

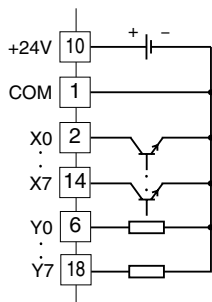

WIRING INSTRUCTIONS

■ SCREW TERMINAL

Torque: 0.5 N·m

■ SOLDERLESS TERMINAL

Refer to the drawing below for recommended ring tongue terminal size. Spade tongue type is also applicable.

Recommended solderless terminal:

• Communication cables

Applicable wire size: 0.2 to 0.5 mm² (AWG 26 to 22)

Recommended manufacturer: Japan Solderless Terminal MFG. Co., Ltd.

• Others

Applicable wire size: 0.25 to 1.65 mm² (AWG 22 to 16)

Recommended manufacturer: Japan Solderless Terminal MFG. Co., Ltd. or Nichifu Co., Ltd.

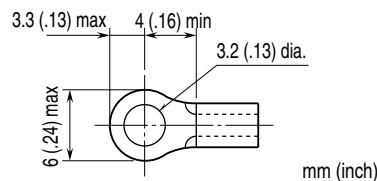

COMMUNICATION CABLE CONNECTIONS

■ MASTER CONNECTION

• Full-duplex communication

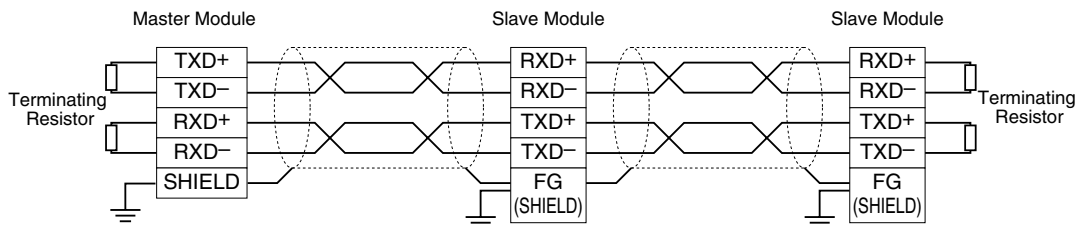

• Half-duplex communication

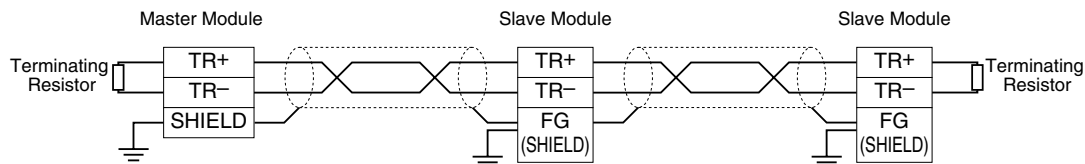

Note: Be sure to turn ON the switch of the terminating resistor located at both ends of the modules.

I/O DATA DESCRIPTIONS

■ DISCRETE I/O

• Di

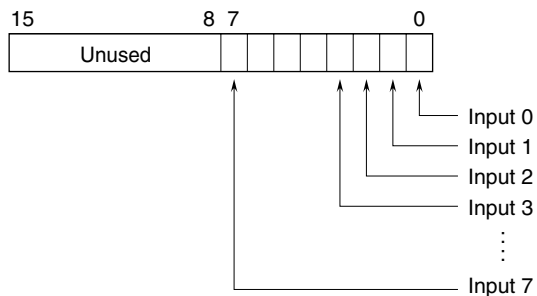

• Do

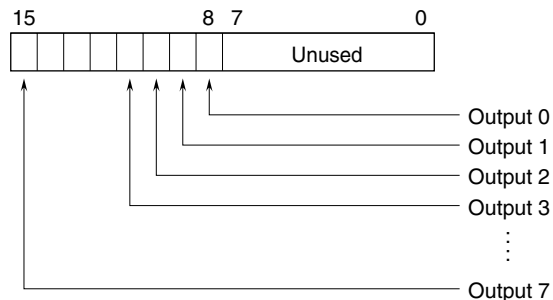

0: OFF

1: ON