

BEFORE USE

Thank you for choosing us. Before use, please check contents of the package you received as outlined below.

If you have any problems or questions with the product, please contact our sales office or representatives.

■ PACKAGE INCLUDES:

RTD input module.....(1)

■ MODEL NO.

Confirm Model No. marking on the product to be exactly what you ordered.

■ INSTRUCTION MANUAL

This manual describes necessary points of caution when you use this product, including installation, connection and basic maintenance procedures.

POINTS OF CAUTION**■ CONFORMITY WITH EU DIRECTIVE**

- Use dual-shield cables (Shinko Seisen Industry Model ZHY262 PBA) for the network. If it is not sufficient, use a ferrite core (Kitagawa Industries Model GRFC-13) for the network cable.
- The equipment must be mounted inside the instrument panel of a metal enclosure.
- The actual installation environments such as panel configurations, connected devices, connected wires, may affect the protection level of this unit when it is integrated in a panel system. The user may have to review the CE requirements in regard to the whole system and employ additional protective measures to ensure the CE conformity.

■ POWER INPUT RATING & OPERATIONAL RANGE

- Locate the power input rating marked on the product and confirm its operational range as indicated below:
24V DC rating: 24V \pm 10%, approx. 90mA

■ GENERAL PRECAUTIONS

- Before you remove the unit or mount it, turn off the power supply and input signal for safety.
- DO NOT set the switches on the module while the power is supplied. The switches are used only for maintenance without the power.

■ ENVIRONMENT

- Indoor use.
- When heavy dust or metal particles are present in the air, install the unit inside proper housing with sufficient ventilation.
- Do not install the unit where it is subjected to continuous vibration. Do not subject the unit to physical impact.
- Environmental temperature must be within -10 to +55°C (14 to 131°F) with relative humidity within 30 to 90% RH in order to ensure adequate life span and operation.

■ WIRING

- Do not install cables close to noise sources (relay drive cable, high frequency line, etc.).
- Do not bind these cables together with those in which noises are present. Do not install them in the same duct.

■ AND

- The unit is designed to function as soon as power is supplied, however, a warm up for 10 minutes is required for satisfying complete performance described in the data sheet.

COMPONENT IDENTIFICATION

■ SIDE VIEW

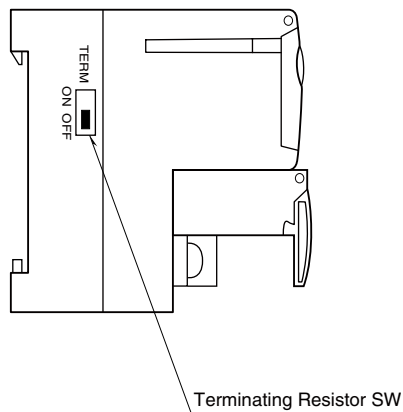

■ FRONT VIEW

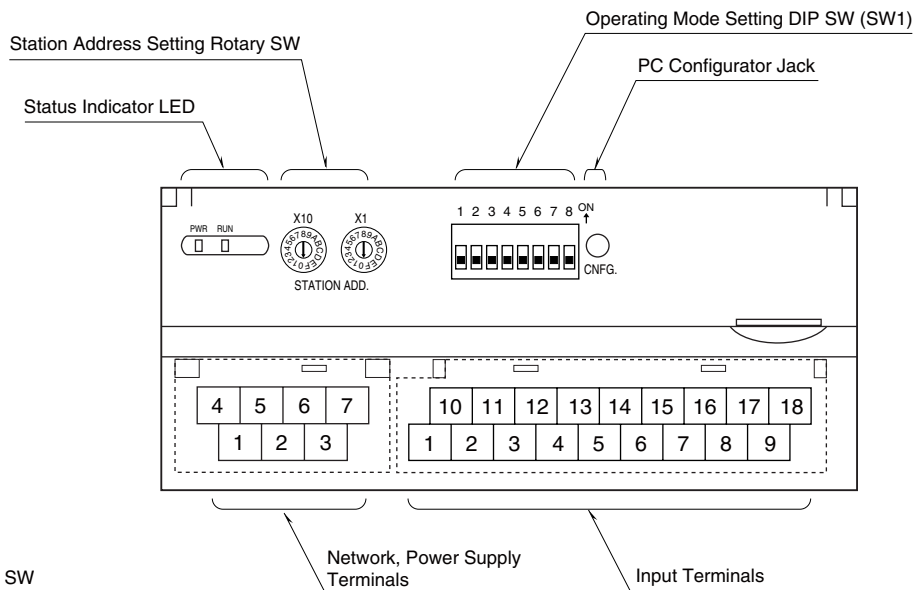

■ STATUS INDICATOR LED

ID	COLOR	FUNCTION
PWR	Green	Turns on when the internal 5V is supplied normally.
RUN	Green	Turns on when the refresh data is received normally.

■ STATION ADDRESS

The left switch determines the sixteenths place digit, while the right switch does the ones place digit of the address. The data allocation is 4.

• Full-duplex communication

Setting “n” with the rotary switches, the addresses are n, n+2, n+4 and n+6. (Range: 01H to 39H)

• Half-duplex communication

Four (4) addresses are assigned from the one set with the rotary switch. (Range: 01H to 3CH)

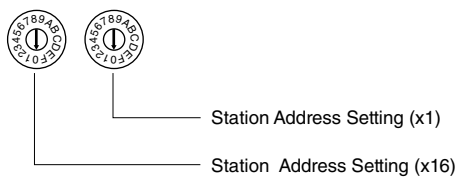

■ OPERATING MODE

(*) Factory setting

• Burnout (SW1-2)

SW1-2	BURNOUT
OFF	Upscale (*)
ON	Downscale

• RTD type (SW1-3, 1-4, 1-5, 1-6)

SW1-3	SW1-4	SW1-5	SW1-6	RTD TYPE
OFF	OFF	OFF	OFF	Pt 100 (JIS '97, IEC) (*)
ON	OFF	OFF	OFF	Pt 100 (JIS '89)
OFF	ON	OFF	OFF	JPt 100 (JIS '89)
ON	ON	OFF	OFF	Pt 50 Ω (JIS '81)
OFF	OFF	ON	OFF	Ni 100
ON	OFF	ON	OFF	Cu 10 @ 25°C
OFF	OFF	OFF	ON	Cu 50
ON	ON	ON	ON	PC Configurator setting

• Transfer rate (SW1-8)

SW1-8	TRANSFER RATE
OFF	12 Mbps (*)
ON	6 Mbps

Note: Be sure to set unused SW1-1 and 1-7 to OFF.

■ TERMINATING RESISTOR

To use the terminating resistor, turn the switch ON, and OFF to invalidate. (Factory setting OFF)

NETWORK, POWER SUPPLY TERMINAL ASSIGNMENT

Full-duplex communication

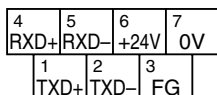

NO.	ID	FUNCTION, NOTES
1	TXD+	Network (slave, transmission +)
2	TXD-	Network (slave, transmission -)
3	FG	FG
4	RXD+	Network (master, transmission +)
5	RXD-	Network (master, transmission -)
6	+24V	Power input (24V DC)
7	0V	Power input (0V)

Half-duplex communication

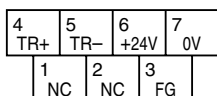

NO.	ID	FUNCTION, NOTES
1	NC	No connection
2	NC	No connection
3	FG	FG
4	TR+	Network
5	TR-	Network
6	+24V	Power input (24V DC)
7	0V	Power input (0V)

INPUT TERMINAL ASSIGNMENT

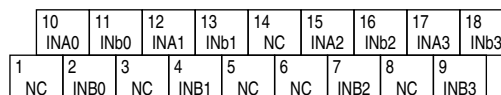

NO.	ID	FUNCTION	NO.	ID	FUNCTION
1	NC	No connection	10	INA0	RTD 0-A
2	INB0	RTD 0-B	11	INb0	RTD 0-b
3	NC	No connection	12	INA1	RTD 1-A
4	INB1	RTD 1-B	13	INb1	RTD 1-b
5	NC	No connection	14	NC	No connection
6	NC	No connection	15	INA2	RTD 2-A
7	INB2	RTD 2-B	16	INb2	RTD 2-b
8	NC	No connection	17	INA3	RTD 3-A
9	INB3	RTD 3-B	18	INb3	RTD 3-b

PC CONFIGURATOR

With configurator software, settings shown below are available.
Refer to the software manual of R7CON for detailed operation.

CHANNEL INDIVIDUAL SETTING

PARAMETER	AVAILABLE RANGE	DEFAULT SETTING
RTD Type	Pt 100 (JIS '97, IEC) Pt 100 (JIS '89) JPt 100 (JIS '89) Pt 50 Ω (JIS '81) Ni 100 Cu 10 @ 25°C Cu 50	Pt 100 (JIS '97, IEC)
Temp Unit	C, F, K	C
Zero scale	-32000 to +32000	0
Full scale	-32000 to +32000	10000
Bias	-320.00 to +320.00	0.00
Gain	-3.2000 to +3.2000	1.0000
Zero temp	Depends on sensor type	0.00 (degC)
Full temp	Depends on sensor type	0.00 (degC)

CHANNEL BATCH SETTING

PARAMETER	AVAILABLE RANGE	DEFAULT SETTING
Conversion rate	0: 250 msec. 1: 500 msec.	0: 250 msec.

TERMINAL CONNECTIONS

Connect the unit as in the diagram below.

EXTERNAL DIMENSIONS unit: mm (inch)

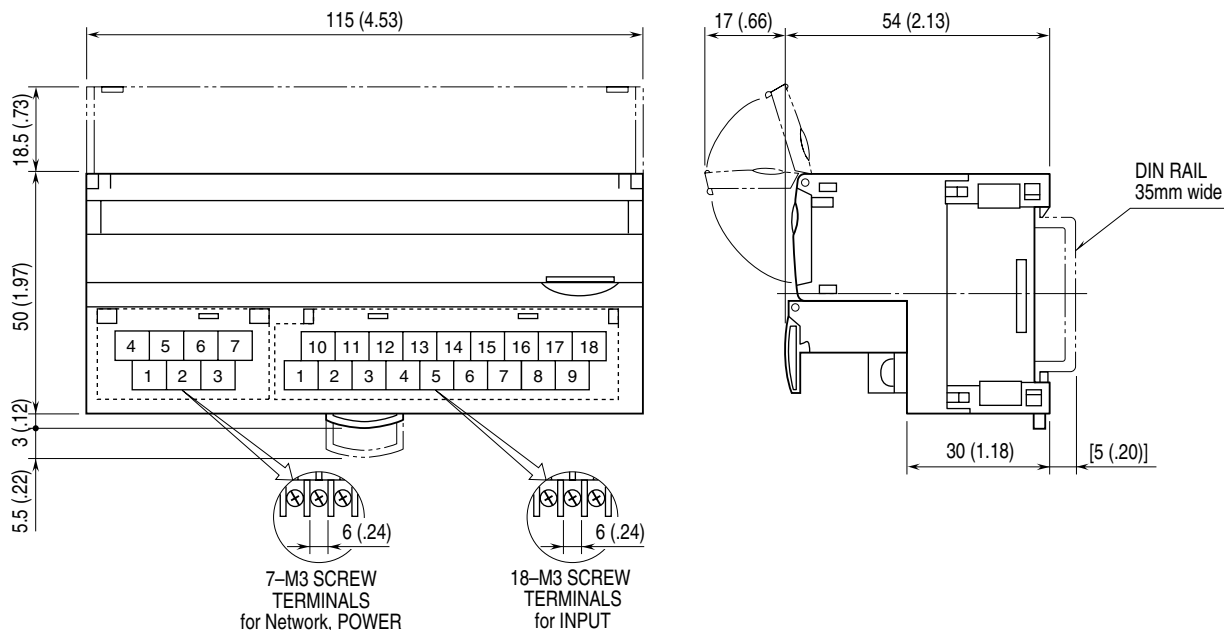

CONNECTION DIAGRAM

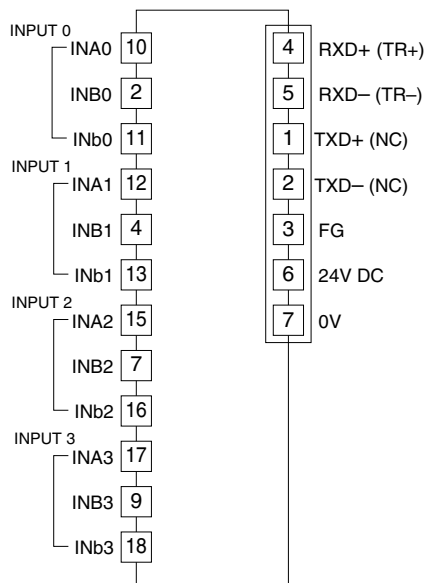

Note 1: Terminal numbers in parentheses are for half-duplex communication model.

Note 2: In order to improve EMC performance, bond the FG terminal to ground.

Caution: FG terminal is NOT a protective conductor terminal.

Input Connection Examples

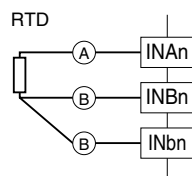

WIRING INSTRUCTIONS

SCREW TERMINAL

Torque: 0.5 N·m

SOLDERLESS TERMINAL

Refer to the drawing below for recommended ring tongue terminal size. Spade tongue type is also applicable.

Recommended solderless terminal:

Communication cables

Applicable wire size: 0.2 to 0.5 mm² (AWG 26 to 22)

Recommended manufacturer: Japan Solderless Terminal MFG. Co., Ltd.

Others

Applicable wire size: 0.25 to 1.65 mm² (AWG 22 to 16)

Recommended manufacturer: Japan Solderless Terminal MFG. Co., Ltd. or Nichifu Co., Ltd.

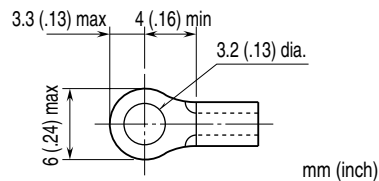

COMMUNICATION CABLE CONNECTIONS

■ MASTER CONNECTION

• Full-duplex communication

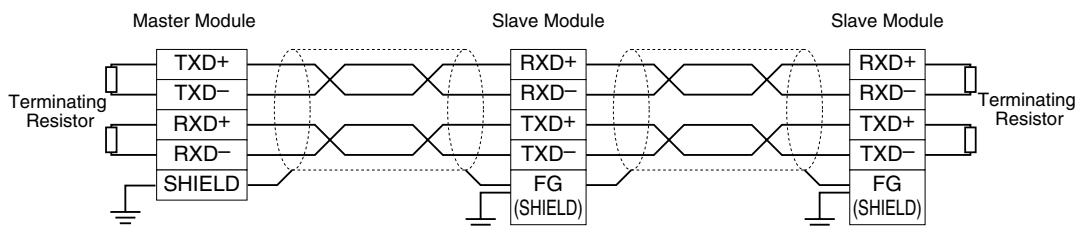

• Half-duplex communication

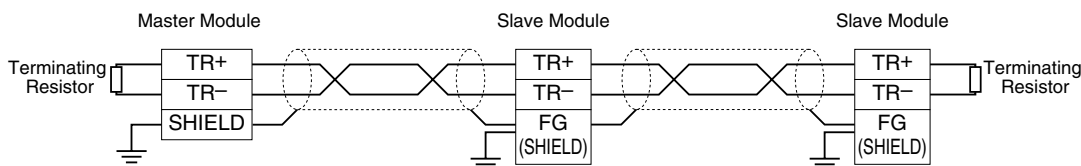

Note: Be sure to turn ON the switch of the terminating resistor located at both ends of the modules.

I/O DATA DESCRIPTIONS

Scaling of analog input is configurable with the configurator software (model: R7CON). Refer to the software manual for details.

■ ANALOG INPUT

• Di

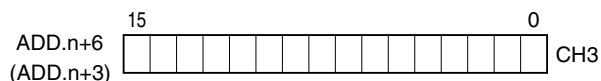
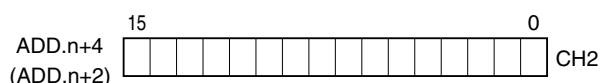
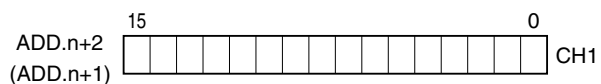
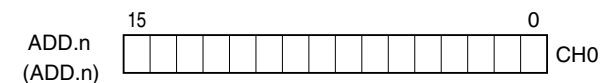

• Do

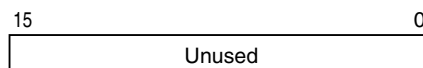
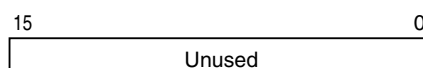
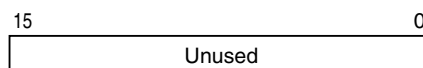
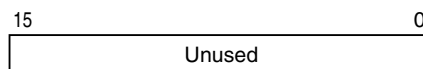

The data is 16-bit binary.

Negative value is represented in 2's complements.

Address in parentheses are for half-duplex mode.