

DC CURRENT INPUT MODULE
(4 points, isolated, screw terminal block)

MODEL **R8-SSN4**

BEFORE USE

Thank you for choosing us. Before use, please check contents of the package you received as outlined below. If you have any problems or questions with the product, please contact our sales office or representatives.

■ **PACKAGE INCLUDES:**

DC current input module.....(1)

■ **MODEL NO.**

Confirm Model No. marking on the product to be exactly what you ordered.

■ **INSTRUCTION MANUAL**

This manual describes necessary points of caution when you use this product, including installation, connection and basic maintenance procedures.

POINTS OF CAUTION

■ **CONFORMITY WITH EU DIRECTIVES**

- The equipment must be mounted inside a panel.
- The actual installation environments such as panel configurations, connected devices, connected wires, may affect the protection level of this device when it is integrated in a panel system. The user may have to review the CE requirements in regard to the whole system and employ additional protective measures* to ensure the CE conformity.

* For example, installation of noise filters and clamp filters for the power source, input and output connected to the device, etc.

■ **GENERAL PRECAUTIONS**

- Before you remove or mount the device, turn off the power supply and input signal for safety.
- Do not touch the terminal block while the power is supplied. Static electricity may cause a malfunction.
- Switches on the side of the device can be set for maintenance only while the power supply is off. Do not access them while the power is supplied.

■ **ENVIRONMENT**

- Indoor use.
- When heavy dust or metal particles are present in the air, install the device inside proper housing with sufficient ventilation.
- Do not install the device where it is subjected to continuous vibration. Do not subject the device to physical impact.
- Environmental temperature must be within -10 to +55°C (14 to 131°F) with relative humidity within 30 to 90% RH in order to ensure adequate life span and operation.

■ **WIRING**

- Do not install cables close to noise sources (relay drive cable, high frequency line, etc.).

- Do not bind these cables together with those in which noises are present. Do not install them in the same duct.
- Be sure to close the terminal cover for safety.

■ **AND**

- The device is designed to function as soon as power is supplied, however, a warm up for 10 minutes is required for satisfying complete performance described in the data sheet.

INSTALLATION

■ **HOW TO MOUNT THE DEVICE ON DIN RAIL**

• **I/O Module**

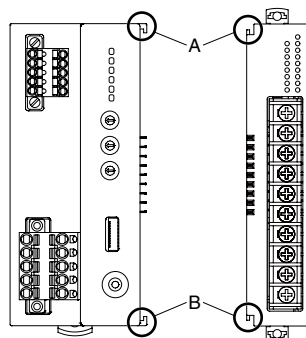

Confirm that the locking clamps of the I/O module are set. Insert the module in parallel to the next one while aligning the grooves of both modules (A & B in the above figure). Maintain it perpendicularly to the rail.

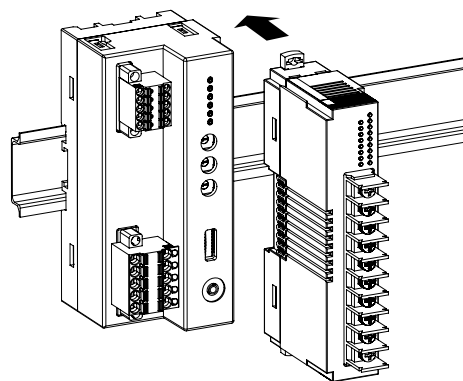

More I/O modules can be added in the same manner.

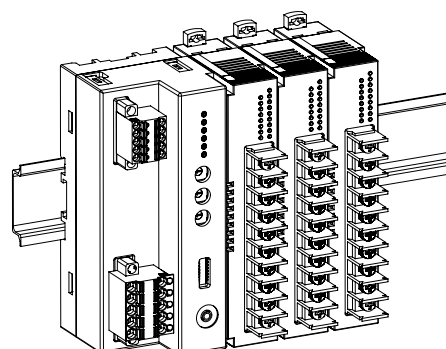

• Protective Cover

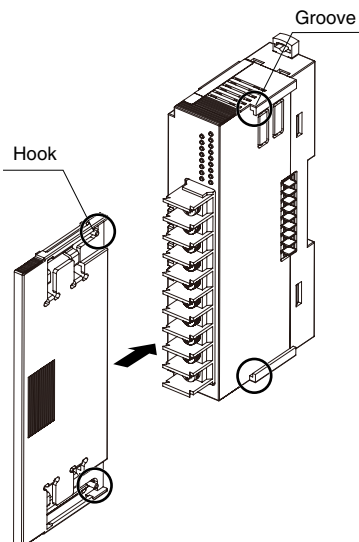

The protective cover is to be attached over the connected I/O module at the right end.
Align the hooks on the cover with the grooves of the module and slide it straight until the hooks are latched.

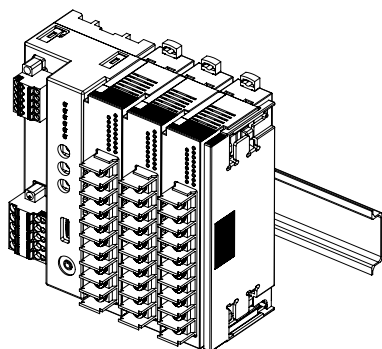

When removing the cover, pull it out while squeezing the hooks inward.

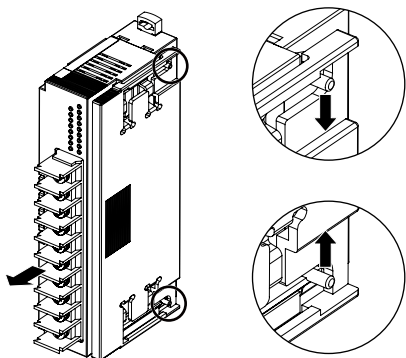

■ HOW TO UNMOUNT THE DEVICE ON DIN RAIL

Release the locking clamps and pull out straight the module.

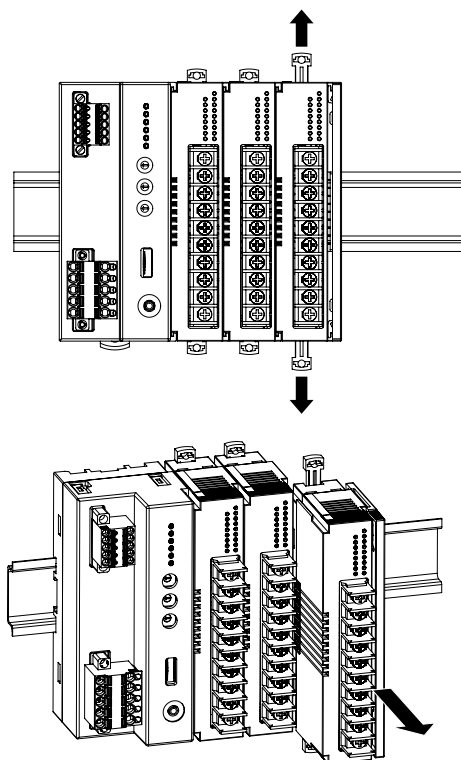

• Removing an intermediate module

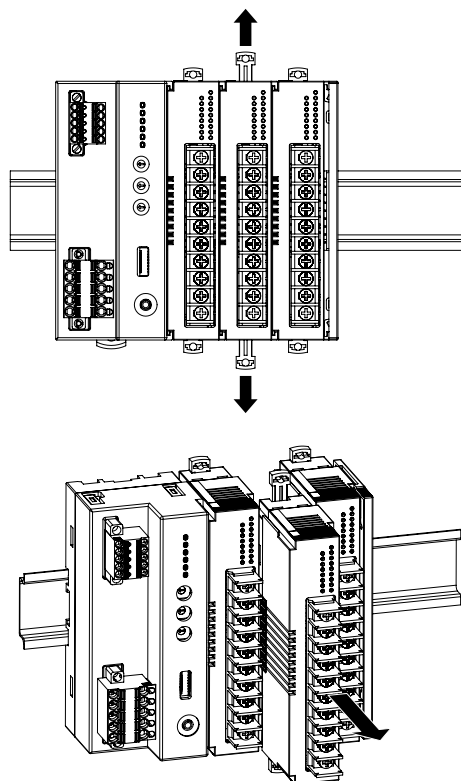

Caution !

- 1) Be careful not to hurt your hand by pointed edges of the internal bus connector.
- 2) I/O modules cannot hold tightly on the DIN rail by themselves without power/network module.
Secure them to the position if necessary by using DIN rail end plates.

COMPONENT IDENTIFICATION

FRONT VIEW

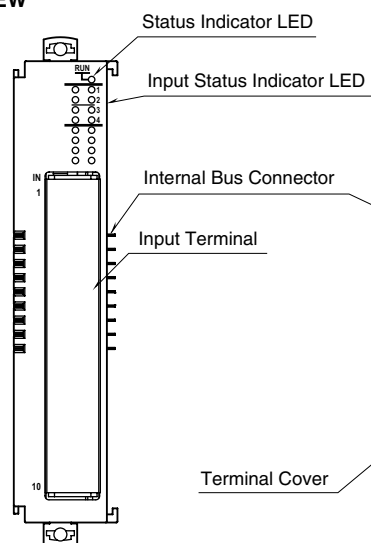

SIDE VIEW

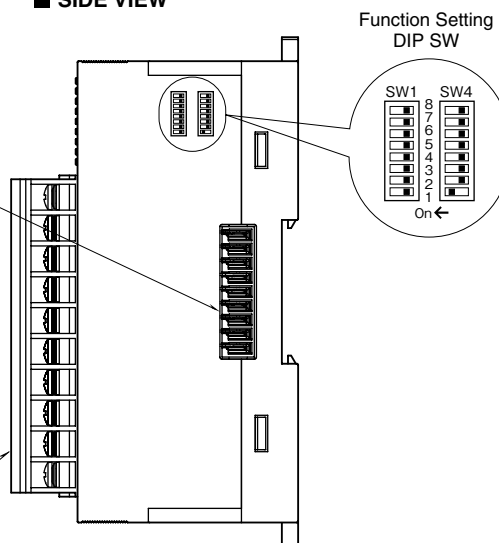

INDICATOR LED

ID	OPERATION	FUNCTION
Status	OFF	Stopping
	Green ON	Valid host communication
	Green Blinking	Reading/writing configuration
	Red ON	Setting error
	Red Blinking	Parameter error
Input Status	OFF	Input data in the range
	Red Blinking	Input data out of range

MODULE ADDRESS: SW1

SW1-1 through 1-4 determine the tenth place digit, while SW1-5 through 1-8 do the ones place digit of the module address.

Address is selected between 0 to 30.

(Factory setting: 0)

MODULE ADDRESS	SW1								
	×10	1	2	3	4				
	×1	5	6	7	8				
0		OFF	OFF	OFF	OFF				
1		OFF	OFF	OFF	ON				
2		OFF	OFF	ON	OFF				
3		OFF	OFF	ON	ON				
4		OFF	ON	OFF	OFF				
5		OFF	ON	OFF	ON				
6		OFF	ON	ON	OFF				
7		OFF	ON	ON	ON				
8		ON	OFF	OFF	OFF				
9		ON	OFF	OFF	ON				

OPERATING MODE

(*) Factory setting

Input Range: SW4-1, 4-2

Same setting for all channels. Use PC Configurator to set independent ranges per channel.

INPUT RANGE	SW4-1	SW4-2
0 – 20mA DC	OFF	OFF
4 – 20mA DC (*)	ON	OFF

Terminator: SW4-6

TERMINATOR	SW4-6
Without (*)	OFF
With	ON

Configuration Mode: SW4-8

CONFIGURATION MODE	SW4-8
DIP switch setting (*)	OFF
PC Configurator and communication	ON

Note: Be sure to set unused SW4-3 through 4-5 and SW4-7 to OFF.

INPUT TERMINAL ASSIGNMENT



PIN No.	ID	FUNCTION
1	In1	Input 1 (+)
2		Input 1 (-)
3	In2	Input 2 (+)
4		Input 2 (-)
5	NC	No connection
6	In3	Input 3 (+)
7		Input 3 (-)
8	In4	Input 4 (+)
9		Input 4 (-)
10	NC	No connection

PC CONFIGURATOR

The following parameter items can be set with using PC Configurator Software (model: R8CFG). Refer to the users manual for the R8CFG for detailed operation of the software program.

■ CHANNEL INDIVIDUAL SETTING

PARAMETER	SETTING RANGE	DEFAULT SETTING
Input Range	-20 to +20 (mA DC)	-20 to +20 (mA DC)
Lower range value	-20.00 to +20.00 (mA)	4.00 (mA)
Upper range value	-20.00 to +20.00 (mA)	20.00 (mA)
Fine zero adjustment	-320.00 to +320.00 (%)	0.00 (%)
Fine gain adjustment	-3.2000 to +3.2000	1.0000
Scaled range Zero	-32000 to +32000	0
Scaled range Span	-32000 to +32000	10000

■ CHANNEL BATCH SETTING

PARAMETER	SETTING RANGE	DEFAULT SETTING
Loss of internal bus communication detection time	0.0 to 99.9 (sec.)	1.0 (sec.)
Moving average	Disable/Enable (8 times)	Disable
Configuration mode	DIP switch (OFF), PC (ON)	DIP switch (OFF)

Note: Be sure to set SW4-8 to ON to configure input range by the PC configurator. Settings are programmed by the PC Configurator via the Power/Network Module.

TERMINAL CONNECTIONS

Connect the device as in the diagram below.

■ EXTERNAL DIMENSIONS unit: mm [inch]

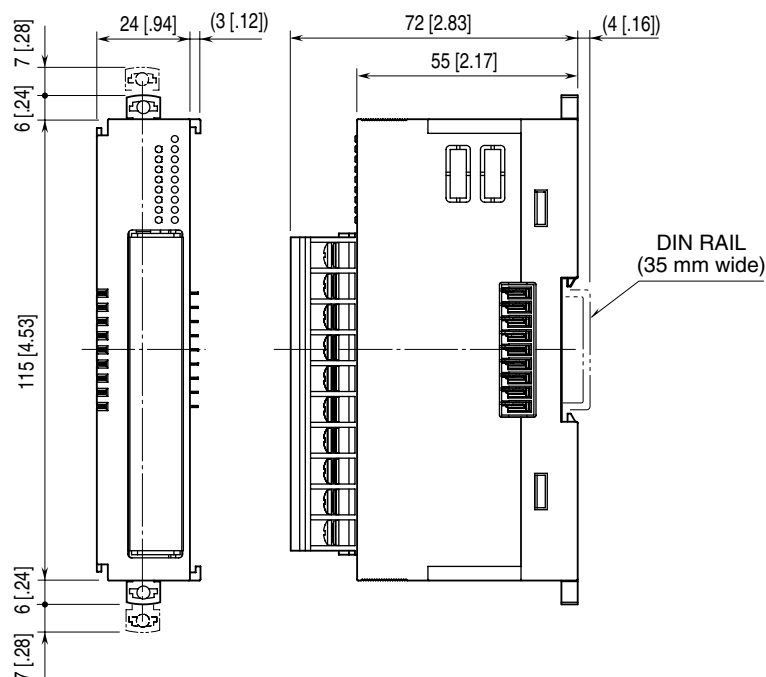

CONNECTION DIAGRAM

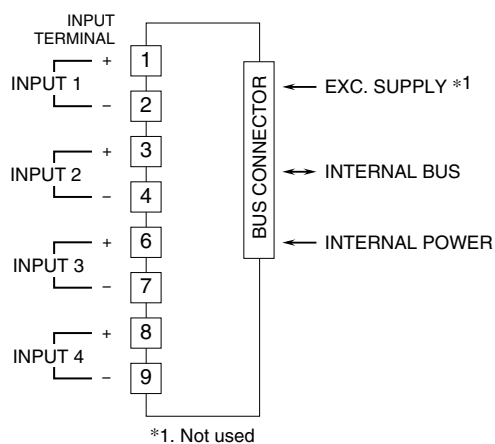

WIRING INSTRUCTIONS

SCREW TERMINAL

Torque: 0.6 N·m

SOLDERLESS TERMINAL

Refer to the drawing below for recommended ring tongue terminal size. Spade tongue type is also applicable.

Applicable wire size: 0.3 to 0.75 mm² (AWG 22 to 20)

Recommended manufacturer: Japan Solderless Terminal MFG.Co.Ltd, Nichifu Co.,ltd

