

MODBUS I/O MODULE

(2 points, universal input)

MODEL **R10M-US2**

BEFORE USE

Thank you for choosing us. Before use, please check contents of the package you received as outlined below.

If you have any problems or questions with the product, please contact our sales office or representatives.

■ PACKAGE INCLUDES:

Modbus I/O module.....(1)
Terminal resistor (110Ω, 0.25W).....(1)
Cold junction sensor (model: CJM).....(2)

■ MODEL NO.

Confirm Model No. marking on the product to be exactly what you ordered.

■ INSTRUCTION MANUAL

This manual describes necessary points of caution when you use this product, including installation, connection and basic maintenance procedures.

For information on Modbus specification, refer to the Modbus Protocol Reference Guide (EM-5650).

This manual is downloadable at our web site.

POINTS OF CAUTION

■ CONFORMITY WITH EU DIRECTIVES

- The equipment must be mounted inside the instrument panel of a metal enclosure.
- The actual installation environments such as panel configurations, connected devices, connected wires, may affect the protection level of this unit when it is integrated in a panel system. The user may have to review the CE requirements in regard to the whole system and employ additional protective measures to ensure the CE conformity.

■ POWER INPUT RATING & OPERATIONAL RANGE

- Locate the power input rating marked on the product and confirm its operational range as indicated below:
24V DC rating: 24V ±10%, ≤ 90mA

■ GENERAL PRECAUTIONS

- Before you remove the terminal block or mount it, turn off input signals for safety.

■ ENVIRONMENT

- Indoor use.
- When heavy dust or metal particles are present in the air, install the unit inside proper housing with sufficient ventilation.
- Do not install the unit where it is subjected to continuous vibration. Do not subject the unit to physical impact.
- Environmental temperature must be within -10 to +55°C (14 to 131°F) with relative humidity within 10 to 90% RH in order to ensure adequate life span and operation.

■ WIRING

- Do not install cables close to noise sources (relay drive cable, high frequency line, etc.).
- Do not bind these cables together with those in which noises are present. Do not install them in the same duct.

■ AND

- The unit is designed to function as soon as power is supplied, however, a warm up for 10 minutes is required for satisfying complete performance described in the data sheet.

COMPONENT IDENTIFICATION

FRONT VIEW

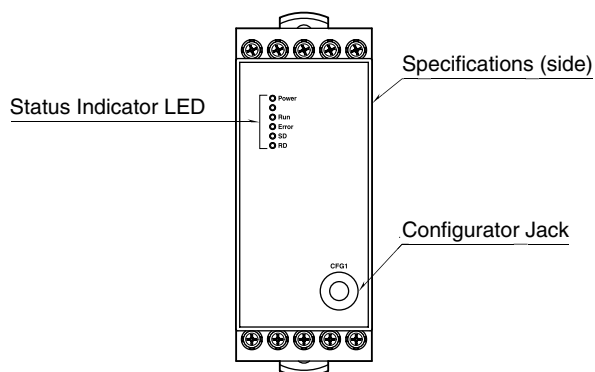

STATUS INDICATORS

ID	STATUS	COLOR	FUNCTION
Power	ON	Green	Power is supplied.
	OFF		Power is not supplied or an abnormality occurs in the unit.
Run	ON	Green	Modbus communication is in normal status.
	OFF		Modbus communication error or during no Modbus communication.
Error	ON	Red	Abnormality occurs in the unit. (i.g. memory failure)
	OFF		Normal status.
SD	ON	Green	Sending data via RS-485
RD	ON	Green	Receiving data via RS-485

TERMINAL ASSIGNMENTS

1	2	3	4	5
U1A	U2A	U1B	U2B	NC
6	7	8	9	10
U3A	U4A	U3B	U4B	NC
11	12	13	14	15
FE	DB	DA	NC	FE1
16	17	18	19	20
SLD	DG	NC	24V	0V

PIN NO.	ID	FUNCTION	PIN NO.	ID	FUNCTION
1	U1A	Input 1-U1	11	FE	Modbus grounding
2	U2A	Input 1-U2	12	DB	DB
3	U1B	Input 2-U1	13	DA	DA
4	U2B	Input 2-U2	14	NC	Unused
5	NC	Unused	15	FE1	Power grounding
6	U3A	Input 3-U1	16	SLD	Shield
7	U4A	Input 3-U2	17	DG	DG
8	U3B	Input 4-U1	18	NC	Unused
9	U4B	Input 4-U2	19	24V	Power supply 24V DC
10	NC	Unused	20	0V	Power supply 0V DC

Universal Input Terminal Assignment

ID	FUNCTION					
	DC Current/DC Voltage (-10 to +10V DC)	DC Voltage (-1000 to +1000mV DC)	Thermocouple	RTD/Resistor (3-wire)	RTD/Resistor (2-wire)	Potentiometer
U1	DC Current/DC Voltage	-	-	-	-	-
U2	-	DC Voltage	Thermocouple +	RTD-b	-	Input S
U3	-	-	CJM	RTD-B	RTD-B	Input L
U4	Common	Common	Thermocouple-, CJM	RTD-A	RTD-A	Input H

CONFIGURATOR SOFTWARE SETTING

The following parameters can be set with using PC Configurator Software (model: R10CFG)
Refer to the users manual for the R30CFG for detailed operation of the software program.

■ UNIVERSAL INPUT SETTING

Each channel can be set independently.

ITEM	SETTING RANGE		DEFAULT SETTING
Input type	DC Current	0 - 20 mA DC	0 - 20 mA DC
	DC Voltage	-1000 - +1000 mV DC, -10 - +10 V DC	
	Potentiometer	0 - 4000 Ω , 0 - 600 Ω , 0 - 300 Ω	
	Resistor	0 - 4000 Ω	
	Thermocouple	(PR), K (CA), E (CRC), J (IC), T (CC), B (RH), R, S, C (WRe 5-26), N, U, L, P (Platinel II)	
RTD	Pt 100, Pt 500, Pt 1000, Pt 50 Ω , JPt 100, Ni 508.4 Ω , Cu 10 (25°C)		
Wiring	2-wire / 3-wire		3-wire
CJC	without / with		with
Temp. unit	°C / °F		°C
Zero input	within the available range		0.000 (mA)
Full input	within the available range (full input \geq zero input)		20.000 (mA)
Zero fine adj.	-5.00 - 5.00 (%)		0.00(%)
Gain fine adj.	0.9500 - 1.0500		1.0000
Zero scaling	-32000 - 32000		0
Full scaling	-32000 - 32000		10000
Burnout	without / with		with
Burnout value	-32768 - 32767		32767
First-order filter time constant	0.0 - 60.0 (sec.)		0.0 (sec.)

■ MODBUS SETTING

ITEM	SETTING RANGE	DEFAULT SETTING
Data Mode	Modbus-RTU / Modbus-ASCII	Modbus-RTU
Address	1 - 247	1
Baud Rate	38400 / 19200 / 9600 / 4800 bps	38400 bps
Parity	None / Odd / Even	None
Communication timeout duration	0.1 - 3200.0 (sec.)	3.0 sec.

Depending on data mode and parity bit setting, data bit and stop bit are as following.

DATA MODE	PARITY BIT	DATA BIT	STOP BIT
Modbus-RTU	None	8	2
	Odd or Even	8	1
Modbus-ASCII	None	7	2
	Odd or Even	7	1

INSTALLATION

The unit can be removed from the base by pulling out while pressing the lockslider on the top thereof.

The base does not come with the unit. Please order separately.

■ DIN RAIL MOUNTING (PARALLEL)

• Mounting the unit

- A) Hook the upper hook at the rear side of the base onto the DIN rail.
- B) Push the lower part of the unit in the direction of the arrow until the base is firmly fixed to the DIN rail.

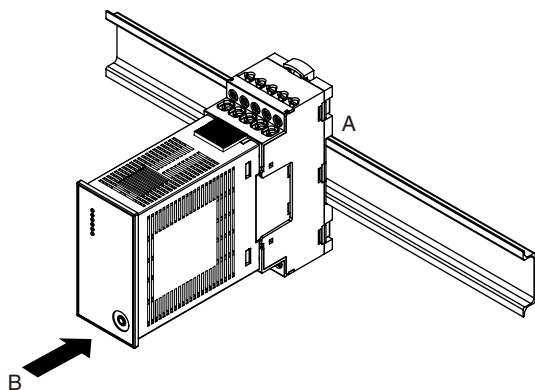

• Removing the unit

- A) Push down the lower slider using a minus screwdriver.
- B) Pull out the lower part of the unit.
- C) Remove the upper part of the unit from the DIN rail.

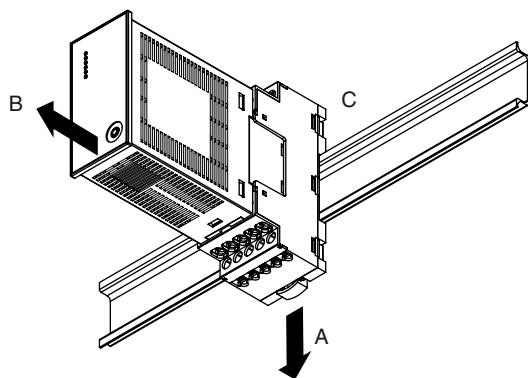

■ WALL MOUNTING

Refer to “MOUNTING REQUIREMENTS unit: mm [inch]” on page 3.

Pull out the upper and lower sliders from the base and fix them with M4 screws (Torque: 1.4 N·m)

TERMINAL CONNECTIONS

Connect the unit as in the diagram below.

EXTERNAL DIMENSIONS unit: mm [inch]

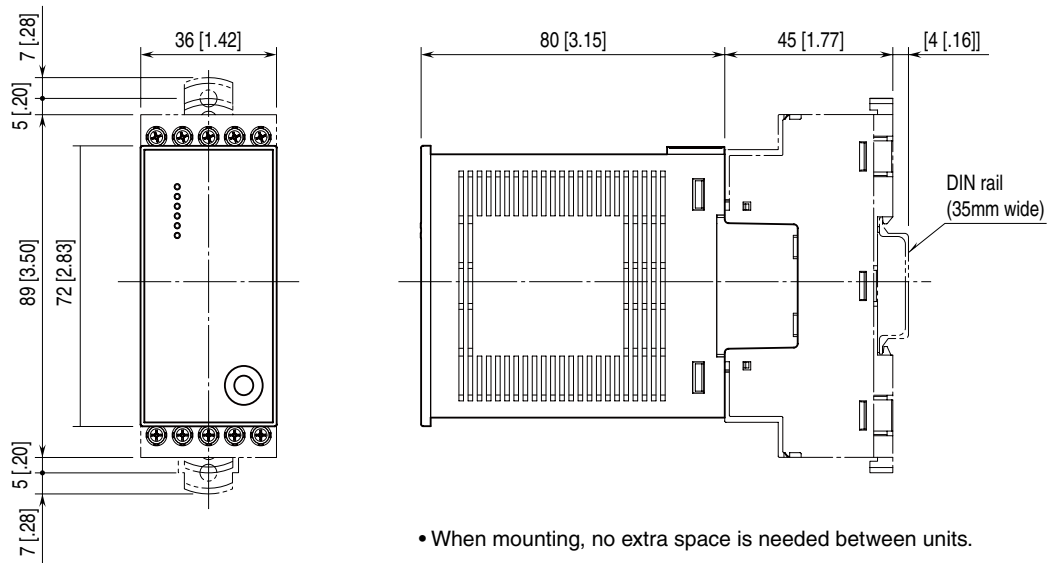

- When mounting, no extra space is needed between units.

■ CONNECTION DIAGRAM

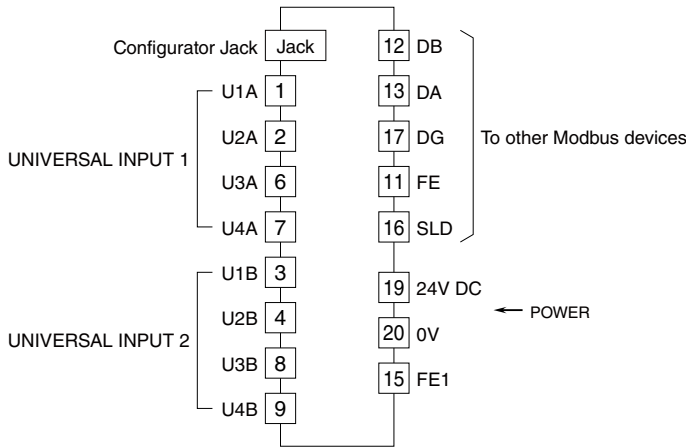

■ UNIVERSAL INPUT CONNECTION

- DC Voltage (-10 ~ +10V)
- DC Current (0 ~ 20mA)

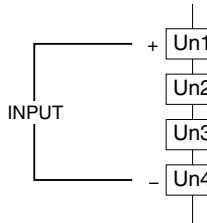

- DC Voltage (-1000 ~ +1000mV)

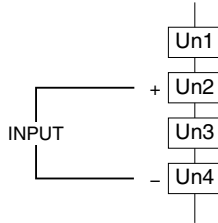

- Thermocouple

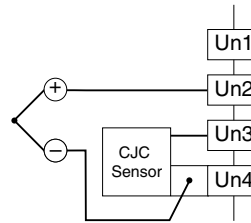

- RTD or Resistor (3-wire)

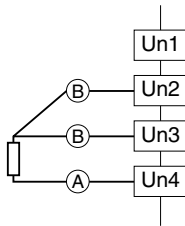

- RTD or Resistor (2-wire)

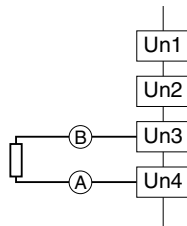

- Potentiometer

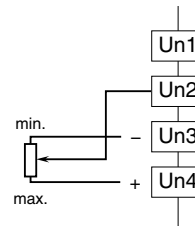

■ TERMINAL ASSIGNMENT

■ BASE

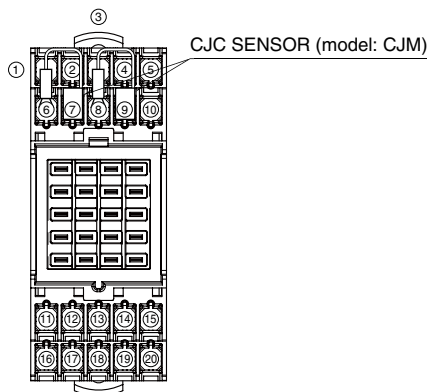

■ MOUNTING REQUIREMENTS unit: mm [inch]

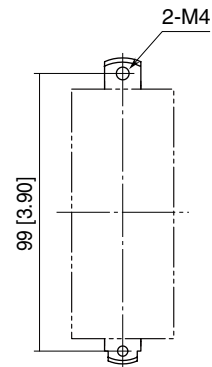

MODBUS WIRING CONNECTION

■ WIRING COMMUNICATION WITH HOST PC

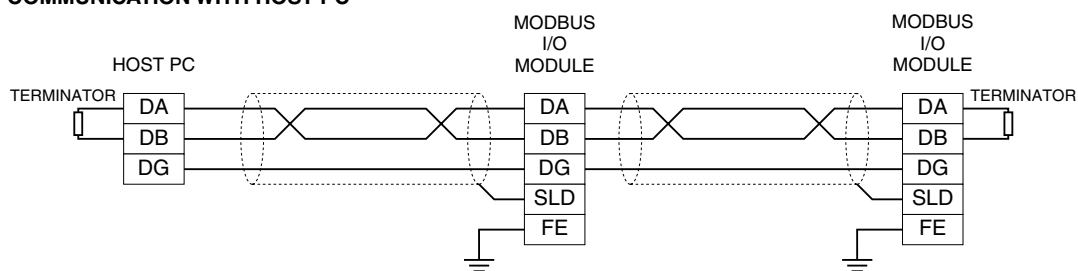

Note: The terminator must be connected across "DA" and "DB" at both ends of communication line.

WIRING INSTRUCTIONS FOR BASE

■ SCREW TERMINAL

Torque: 0.5 N·m

■ SOLDERLESS TERMINAL

Refer to the drawing below for recommended ring tongue terminal size. Spade tongue type is also applicable.

Recommended manufacturer: Japan Solderless Terminal MFG.Co.Ltd, Nichifu Co.,Ltd

(Solderless terminals with insulation sleeve do not fit)

Applicable wire size: 0.25 to 1.65 mm²

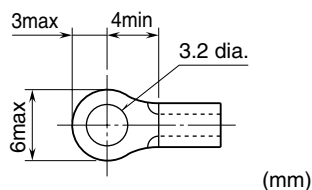

■ HOW TO ATTACH CJC SENSOR

In re-attaching once removed CJC sensor, connect it to terminals U3x and U4x as shown below.

A RTD is attached on the REAR surface of the CJC sensor.

In order to measure accurate reference junction temperature, be sure to connect the sensor to terminal U4x with its upside FRONT surface

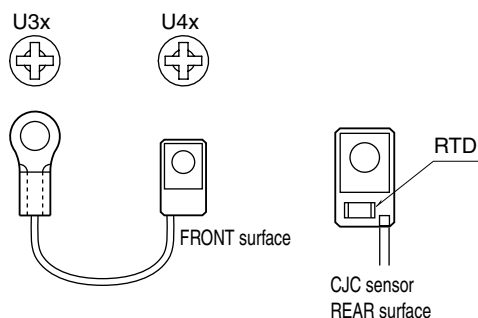

MODBUS FUNCTION CODES & SUPPORTED CODES

Modbus function codes are shown below

■ DATA AND CONTROL FUNCTIONS

CODE	NAME	
02	Read Input Status	Status of digital inputs to the slave (read only)
04	Read Input Registers	Collected data from the field by the slave (read only)

■ EXCEPTION CODES

CODE	NAME	
01	Illegal Function	Function code is not allowable for the slave
02	Illegal Data Address	Address is not available within the slave
03	Illegal Data Value	Data is not valid for the function

MODBUS I/O ASSIGNMENT

	ADDRESS	DATA TYPE	DATA
Input (1X)	1		Analog input 1 error (burnout / input range error)
	2		Analog input 2 error (burnout / input range error)
Input Register (3X)	1	I	Analog Input (analog input 1)
	2	I	Analog Input (analog input 2)

Note: DO NOT access addresses other than the ones mentioned above. Such access may cause problems such as malfunction.

■ DATA TYPE

I: Integer, -32768 – 32767

■ STATUS

1 bit: indicates input status.

Burnout / input range error

(Input range is out of the range -5 to +105% for scaling setting, or out of the range -32768 to +32767)

0: Normal

1: Error

I/O DATA DESCRIPTIONS

■ UNIVERSAL INPUT DATA (SCALING CONVERSION DATA, 16 bit)

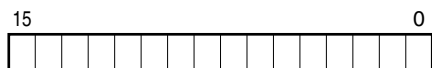

When scaling setting is initial value, 0 to 10000, data is 0 to 10000 for input 0 to 100% setting.
Input range is -5 to +105% (-500 to +10500). When out of input range, it is fixed to -500 or +10500.
Minus value is converted into negative values, represented in 2's complements.

■ UNIVERSAL INPUT DATA (TEMPERATURE DATA, 16 bit)

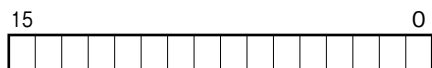

When setting both zero input and full input to 0 with thermocouple or RTD input, response it as temperature data.
With °C temperature unit, raw data is multiplied by 10. For example, 25.5°C is converted into 255.
With °F temperature unit, the integer section of raw data is directly converted into the data.
Minus temperature is converted into negative values, represented in 2's complements.

■ DATA ERROR STATUS (1 bit)

Data error status is indicated by 1 bit.

0: OFF

1: ON

LIGHTNING SURGE PROTECTION

We offer a series of lightning surge protector for protection against induced lightning surges. Please contact us to choose appropriate models