

**NPN TRANSISTOR INPUT MODULE, 16 points**  
(Tension clamp terminal block)

**MODEL R8-DAT16A2**

**BEFORE USE ....**

Thank you for choosing us. Before use, please check contents of the package you received as outlined below. If you have any problems or questions with the product, please contact our sales office or representatives.

**■ PACKAGE INCLUDES:**

Discrete input module.....(1)

**■ MODEL NO.**

Confirm Model No. marking on the product to be exactly what you ordered.

**■ INSTRUCTION MANUAL**

This manual describes necessary points of caution when you use this product, including installation, connection and basic maintenance procedures.

**POINTS OF CAUTION**

**■ CONFORMITY WITH EU DIRECTIVES**

- The equipment must be mounted inside a panel.
- The actual installation environments such as panel configurations, connected devices and connected wires may affect the protection level of this unit when it is integrated in a panel system. The user may have to review the CE requirements in regard to the whole system and employ additional protective measures to ensure CE conformity.

**■ GENERAL PRECAUTIONS**

- Before you remove or mount the unit, turn off the power supply and input signal for safety.
- Switches on the side of the module can be set for maintenance only while the power supply is off. Do not access them while the power is supplied.

**■ ENVIRONMENT**

- Indoor use.
- When heavy dust or metal particles are present in the air, install the unit inside proper housing with sufficient ventilation.
- Do not install the unit where it is subjected to continuous vibration. Do not subject the unit to physical impact.
- Environmental temperature must be within -10 to +55°C (14 to 131°F) with relative humidity within 30 to 90% RH in order to ensure adequate life span and operation.

**■ WIRING**

- Do not install cables close to noise sources (relay drive cable, high frequency line, etc.).
- Do not bind these cables together with those in which noises are present. Do not install them in the same duct.

**■ EXCITATION SUPPLY**

- Input connector: Rated current 3 A DC (rated current 3 A for internal fuse (slow blow fuse  $i^2t$  (A<sup>2</sup>sec) max. 5.04).

**■ AND ....**

- The unit is designed to function as soon as power is supplied, however, a warm up for 10 minutes is required for satisfying complete performance described in the data sheet.

**INSTALLATION**

**■ HOW TO MOUNT THE MODULE ON DIN RAIL**

**• I/O Module**

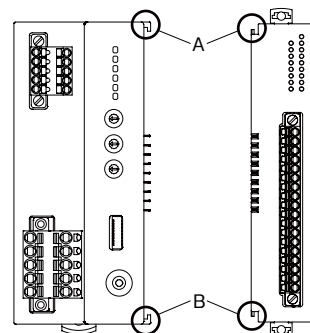

Confirm that the locking clamps of the I/O module are set. Insert the module in parallel to the next one while aligning the grooves of both modules (A & B in the above figure). Maintain it perpendicularly to the rail.

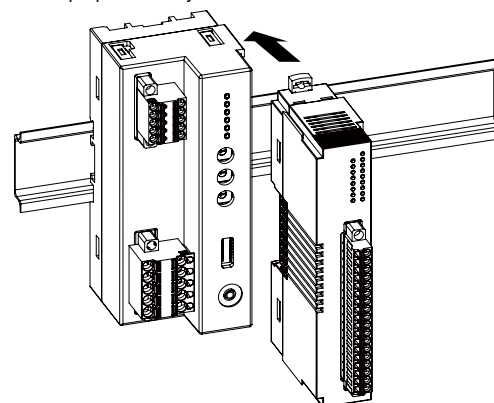

More I/O modules can be added in the same manner.

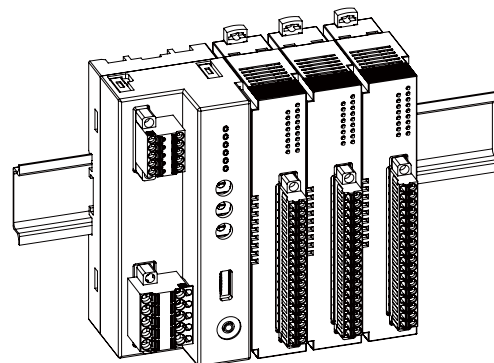

• Protective Cover

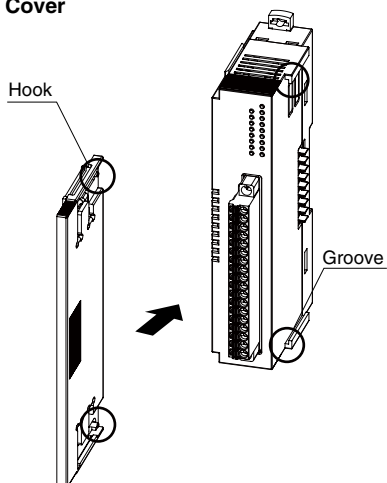

The protective cover is to be attached over the connected I/O module at the right end.  
Align the hooks on the cover with the grooves of the module and slide it straight until the hooks are latched.

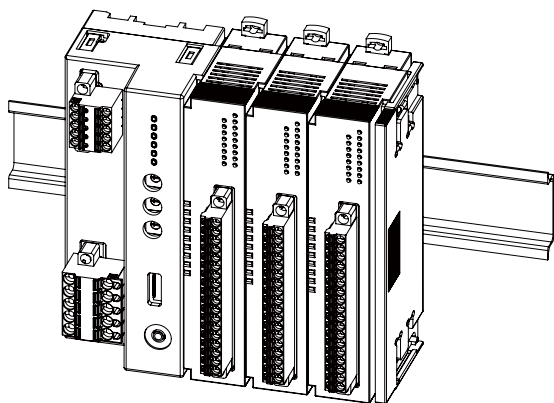

When removing the cover, pull it out while squeezing the hooks inward.

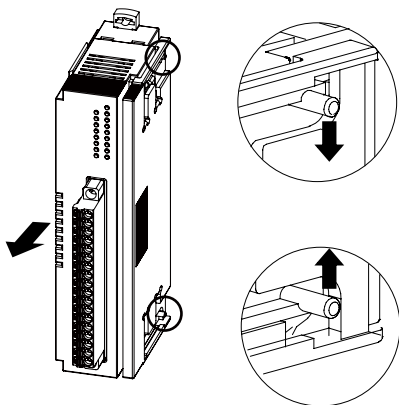

■ HOW TO UNMOUNT THE MODULE FROM DIN RAIL

Release the locking clamps and pull out straight the module.

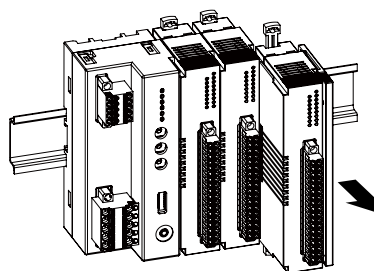
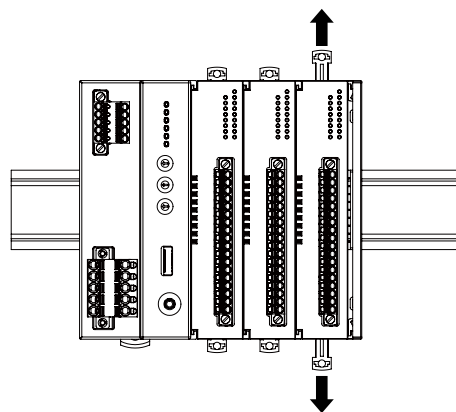

• Removing an intermediate module

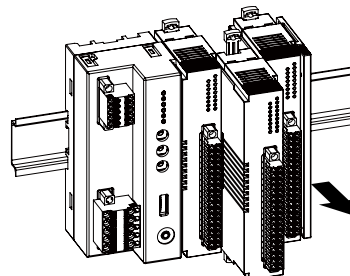
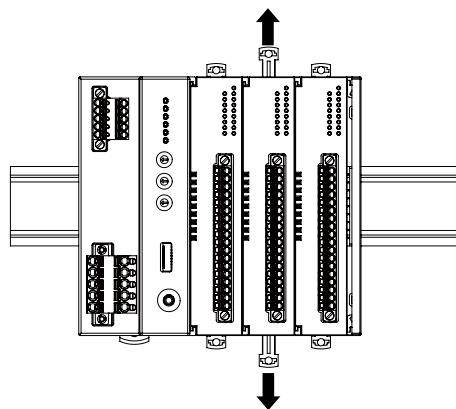

**Caution !**

- 1) Be careful not to hurt your hand by pointed edges of the internal communication bus connector.
- 2) I/O modules cannot hold tightly on the DIN rail by themselves without power/network module.  
Secure them to the position if necessary by using DIN rail end plates.

## COMPONENT IDENTIFICATION

### FRONT VIEW

### SIDE VIEW

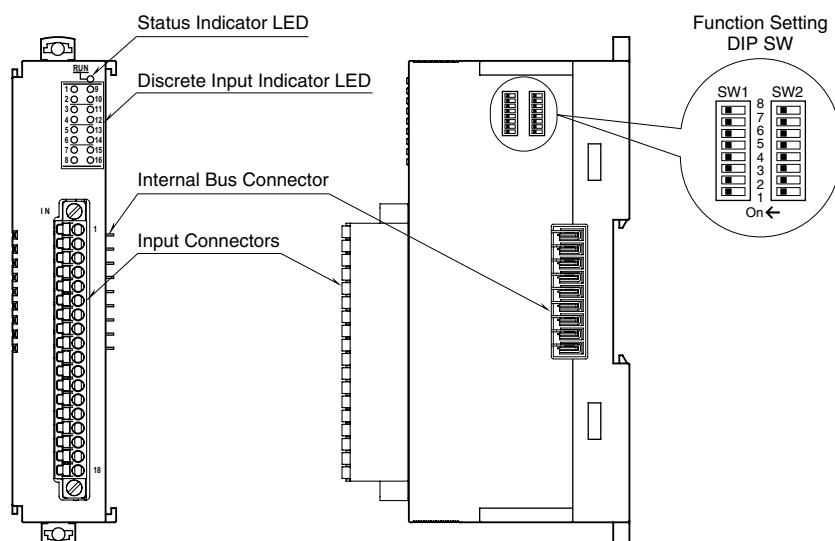

### INDICATOR LED

LED	OPERATION	FUNCTION
Status	OFF	Stopping
	Green ON	Valid host communication
	Green Blinking	Reading/writing configuration
	Red ON	Setting error
	Red Blinking	Parameter error
Input Status	OFF	OFF
	Green ON	ON

### INPUT CONNECTOR ASSIGNMENT

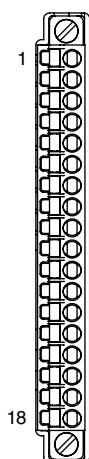

PIN No.	ID	FUNCTION
1	Di 1	Input 1
2	Di 2	Input 2
3	Di 3	Input 3
4	Di 4	Input 4
5	Di 5	Input 5
6	Di 6	Input 6
7	Di 7	Input 7
8	Di 8	Input 8
9	Di 9	Input 9
10	Di 10	Input 10
11	Di 11	Input 11
12	Di 12	Input 12
13	Di 13	Input 13
14	Di 14	Input 14
15	Di 15	Input 15
16	Di 16	Input 16
17	0V	Excitation supply 0V
18	24V	Excitation supply 24V

### MODULE ADDRESS

The SW1-1, SW1-2, SW1-3, SW1-4 determines the tenth place digit, while the SW1-5, SW1-6, SW1-7, SW1-8 does the ones place digit of the address.

Address is selected between 0 to 31.

(Factory setting: 0)

MODULE ADDRESS	SW1				
	×10	1	2	3	
	×1	5	6	7	
0		OFF	OFF	OFF	OFF
1		OFF	OFF	OFF	ON
2		OFF	OFF	ON	OFF
3		OFF	OFF	ON	ON
4		OFF	ON	OFF	OFF
5		OFF	ON	OFF	ON
6		OFF	ON	ON	OFF
7		OFF	ON	ON	ON
8		ON	OFF	OFF	OFF
9		ON	OFF	OFF	ON

### TERMINATOR DIP SW

TERMINATOR SW	SW2-6
Without (*)	OFF
With	ON

(\*) Factory setting

Note: Be sure to set unused SW2-1 through 2-5, 2-7 and 2-8 to OFF.

### PC CONFIGURATOR

The following parameters can be set with using PC Configurator Software (model: R8CFG):

- Loss of internal bus communication detection time
- Sampling cycle

Settings are programmed by the PC Configurator via the Power/Network Module. Refer to the users manual for the R8CFG for detailed operation of the software program.

# TERMINAL CONNECTIONS

Connect the unit as in the diagram below.

## EXTERNAL DIMENSIONS unit: mm (inch)

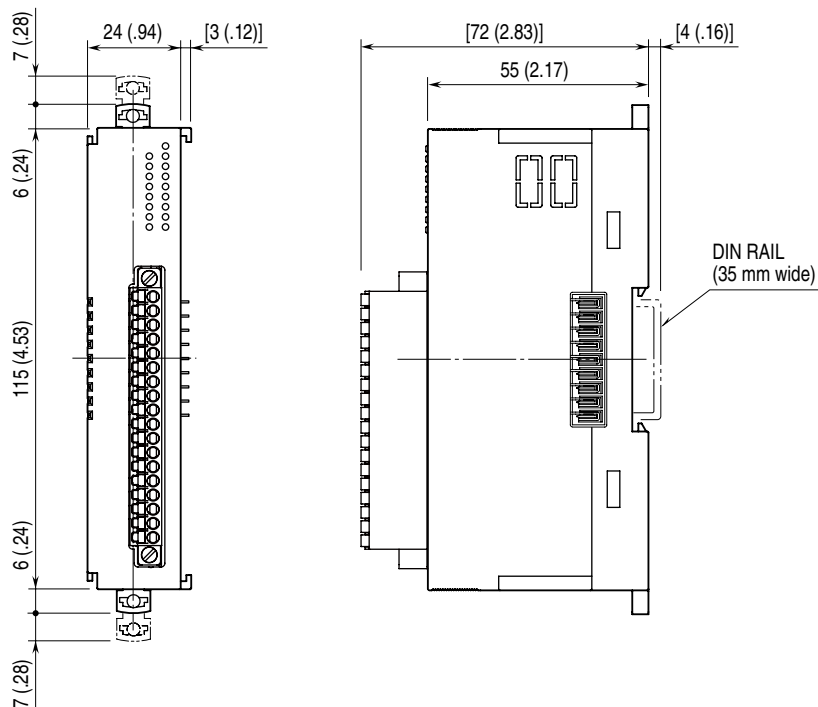

## CONNECTION DIAGRAM

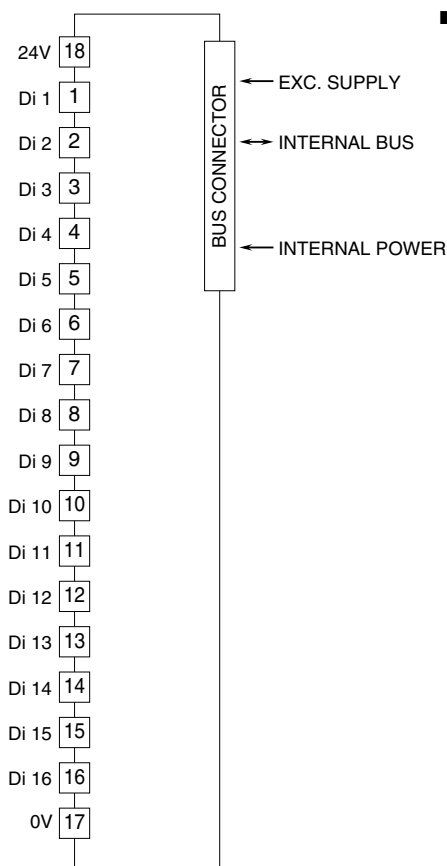

## INPUT CIRCUIT

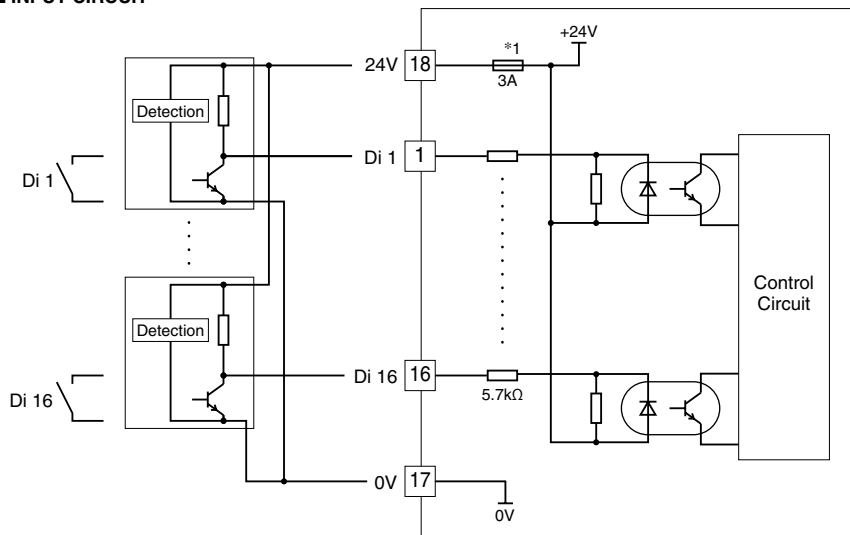

---

## WIRING INSTRUCTIONS

### ■ TENSION CLAMP TERMINAL BLOCK

**Unit side connector:** MC 1,5/18-GF-3,5  
(Phoenix Contact)

**Cable side connector:** FMC 1,5/18-STF-3,5  
(Phoenix Contact)

**Applicable wire size:** 0.2 – 1.5 mm<sup>2</sup>

**Stripped length:** 10 mm

#### Recommended solderless terminal

- AI0,25-10YE 0.25 mm<sup>2</sup> (Phoenix Contact)
- AI0,34-10TQ 0.34 mm<sup>2</sup> (Phoenix Contact)
- AI0,5-10WH 0.5 mm<sup>2</sup> (Phoenix Contact)
- AI0,75-10GY 0.75 mm<sup>2</sup> (Phoenix Contact)
- A1-10 1.0 mm<sup>2</sup> (Phoenix Contact)
- A1,5-10 1.5 mm<sup>2</sup> (Phoenix Contact)