

**RELAY OUTPUT MODULE  
(4 points, tension clamp terminal block)**

MODEL **R80DCT4D**

**BEFORE USE ....**

Thank you for choosing us. Before use, please check contents of the package you received as outlined below. If you have any problems or questions with the product, please contact our sales office or representatives.

**■ PACKAGE INCLUDES:**

DC voltage output module.....(1)

**■ MODEL NO.**

Confirm Model No. marking on the product to be exactly what you ordered.

**■ INSTRUCTION MANUAL**

This manual describes necessary points of caution when you use this product, including installation, connection and basic maintenance procedures.

**POINTS OF CAUTION**

**■ CONFORMITY WITH EU DIRECTIVES**

- This equipment is suitable for Pollution Degree 2 and Measurement Category II (output, transient voltage 2500 V). Basic insulation (output to exc. supply or internal bus or internal power: 250V) is maintained. Prior to installation, check that the insulation class of this unit satisfies the system requirements.
- The equipment must be mounted inside a panel.
- Altitude up to 2000 meters.
- The equipment must be installed such that appropriate clearance and creepage distances are maintained to conform to CE requirements. Failure to observe these requirements may invalidate the CE conformance.
- The actual installation environments such as panel configurations, connected devices, connected wires, may affect the protection level of this unit when it is integrated in a panel system. The user may have to review the CE requirements in regard to the whole system and employ additional protective measures\* to ensure the CE conformity.  
\* For example, installation of noise filters and clamp filters for the power source, input and output connected to the unit, etc.

**■ GENERAL PRECAUTIONS**

- Before you remove or mount the unit, turn off the power supply and output signal for safety.
- DO NOT set the switches while the power is supplied. The switches are used only for maintenance without the power.

**■ ENVIRONMENT**

- Indoor use.
- When heavy dust or metal particles are present in the air, install the unit inside proper housing with sufficient ventilation.
- Do not install the unit where it is subjected to continuous vibration. Do not subject the unit to physical impact.
- Environmental temperature must be within -10 to +55°C (14 to 131°F) with relative humidity within 10 to 90% RH in order to ensure adequate life span and operation.

**■ WIRING**

- Do not install cables close to noise sources (relay drive cable, high frequency line, etc.).
- Do not bind these cables together with those in which noises are present. Do not install them in the same duct.

**■ POWER UP**

- The unit is designed to function as soon as power is supplied, however, a warm up for 10 minutes is required for satisfying complete performance described in the data-sheet.

**INSTALLATION**

**■ HOW TO MOUNT THE MODULE ON DIN RAIL**

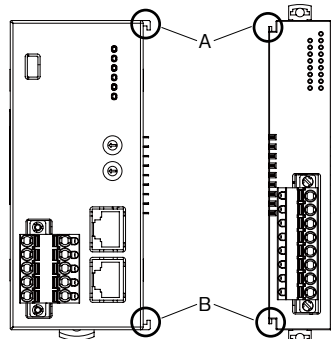

Confirm that the locking clamps of the extension power supply module are set. Insert the module in parallel to the next one while aligning the grooves of both modules (A & B in the above figure). Maintain it perpendicularly to the rail.

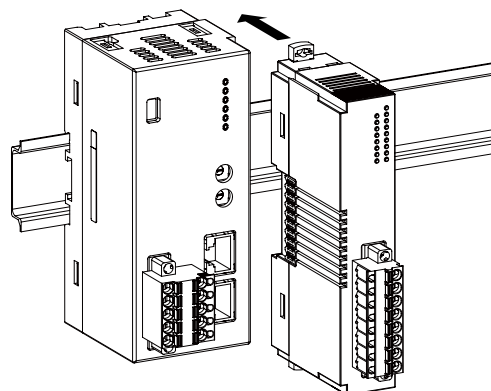

More I/O modules can be added in the same manner.

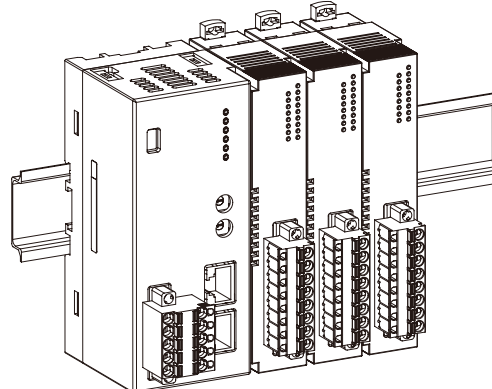

• Protective Cover

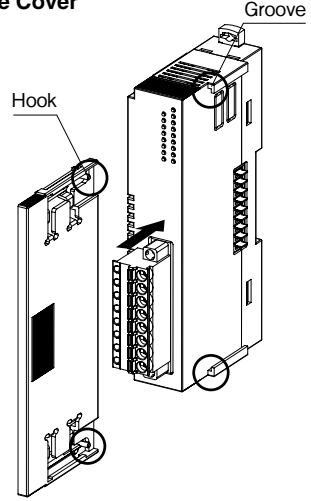

The protective cover is to be attached over the connected I/O module at the right end.  
Align the hooks on the cover with the grooves of the module and slide it straight until the hooks are latched.

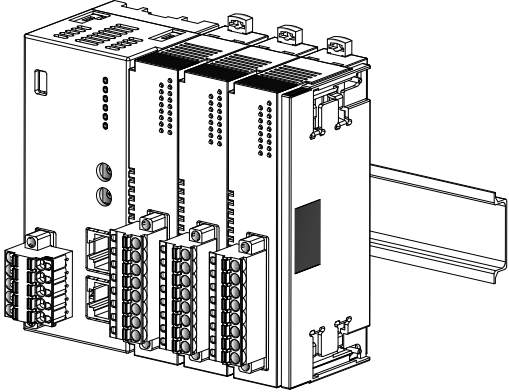

When removing the cover, pull it out while squeezing the hooks inward.

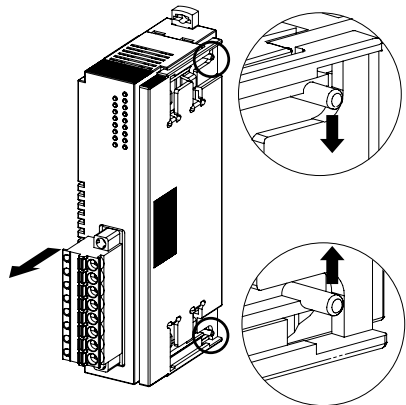

■ HOW TO UNMOUNT THE MODULE FROM DIN RAIL

Release the locking clamps and pull out straight the module.

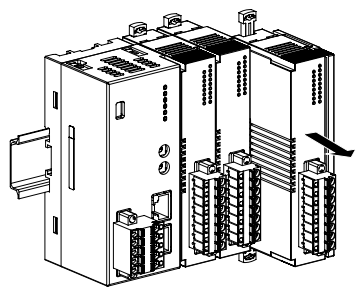
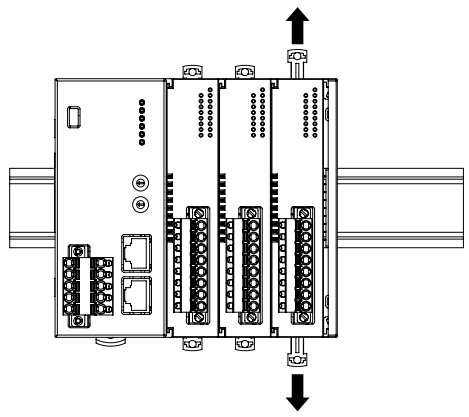

• Removing an intermediate module

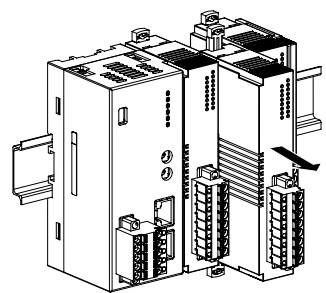
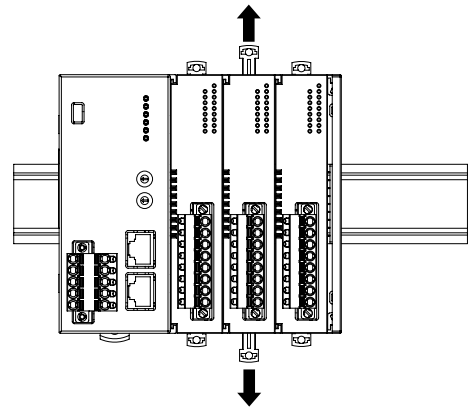

Caution !

- 1) Be careful not to hurt your hand by pointed edges of the internal bus connector.
- 2) I/O modules cannot hold tightly on the DIN rail by themselves without power/network module.  
Secure them to the position if necessary by using DIN rail end plates.

**COMPONENT IDENTIFICATION**

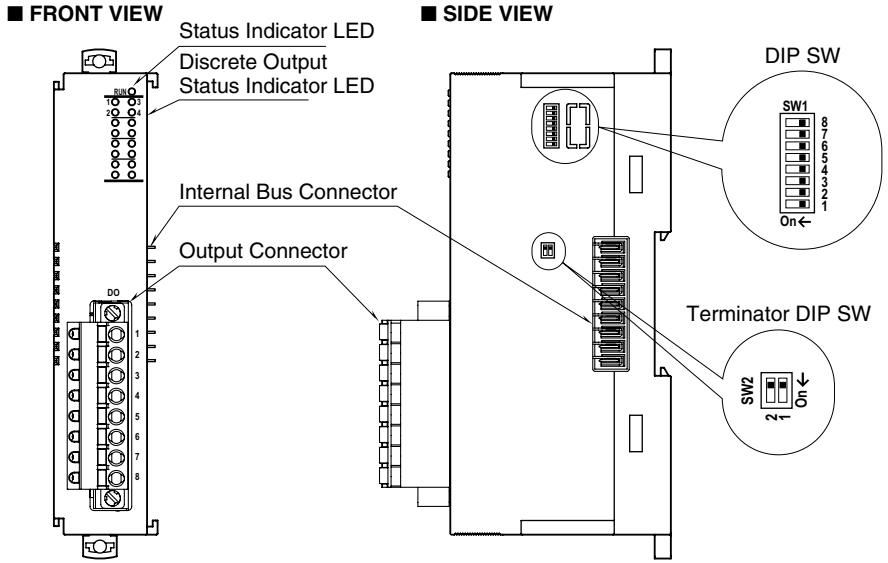

**STATUS INDICATOR LED / OUTPUT STATUS INDICATOR LED**

LED	OPERATION	COLOR	FUNCTION
RUN Indicator LED	ON	Red	Upper communication: Stopping or abnormal Internal communication: Abnormal
	ON	Green	Upper communication: Normal Internal communication: Normal
	Blink 400 msec. cycle	-	Output circuit abnormality
	OFF	-	Upper communication: Stopping or abnormal Internal communication: Normal
Output Status Indicator LED	OFF	Green	Discrete OFF
	ON		Discrete ON

## ■ OPERATION MODE SETTING

(\*) factory default setting

Note) Be sure to unused SW1-5 through 1-8 and 2-2to OFF.

### • Module Address Setting

Configure the module address with DIP Switch.

0 - 15 are available for module address.

MODULE ADDRESS	SW1			
	1	2	3	4
0(*)	OFF	OFF	OFF	OFF
1	ON	OFF	OFF	OFF
2	OFF	ON	OFF	OFF
3	ON	ON	OFF	OFF
4	OFF	OFF	ON	OFF
5	ON	OFF	ON	OFF
6	OFF	ON	ON	OFF
7	ON	ON	ON	OFF
8	OFF	OFF	OFF	ON
9	ON	OFF	OFF	ON
10	OFF	ON	OFF	ON
11	ON	ON	OFF	ON
12	OFF	OFF	ON	ON
13	ON	OFF	ON	ON
14	OFF	ON	ON	ON
15	ON	ON	ON	ON

### • Terminator Setting

Terminator	SW2-1
Disabled (*)	OFF
Enabled	ON

## ■ OUTPUT CONNECTOR TERMINAL ASSIGNMENT

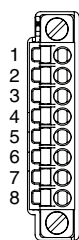

PIN NO.	ID	FUNCTION
1	Do1	Output 1
2	Do1	Output 1
3	Do2	Output 2
4	Do2	Output 2
5	Do3	Output 3
6	Do3	Output 3
7	Do4	Output 4
8	Do4	Output 4

## PC CONFIGURATOR

The following parameters can be set with using PC Configurator Software (model: R80CFG)  
 Refer to the users manual for the R80CFG for detailed operation of the software program.  
 Each channel can be set individually.

### CHANNEL INDIVIDUAL SETTING

ITEM	SETTING RANGE	DEFAULT VALUE
Output at the startup	ON OFF	OFF

### CHANNEL BATCH SETTING

ITEM	SETTING RANGE	DEFAULT VALUE
Version no.	-	-
Output at the loss of communication	Hold the output data User set data output	Hold the output data
Simulate output	Normal output Simulation data	Normal output

## TERMINAL CONNECTIONS

Connect the unit as in the diagram below.

### EXTERNAL DIMENSIONS unit : mm [inch]

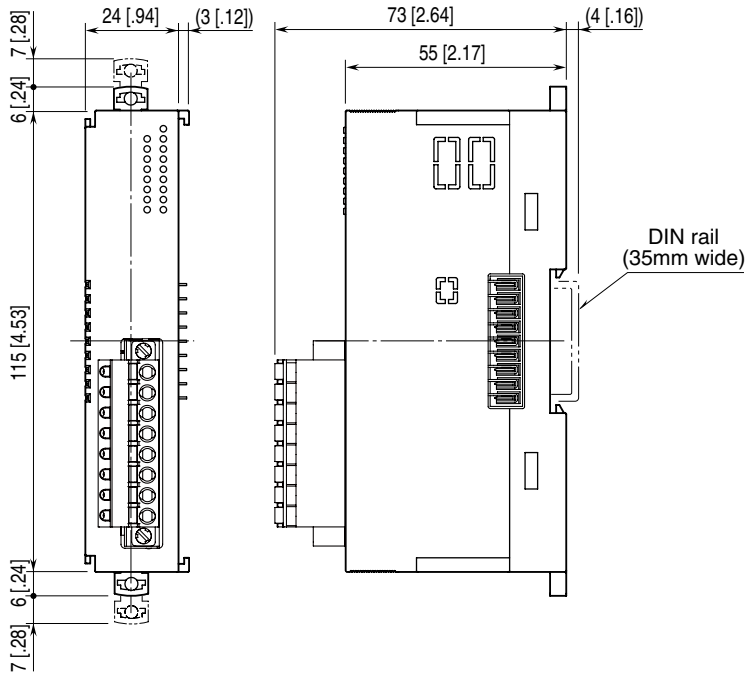

## ■ CONNECTION DIAGRAM

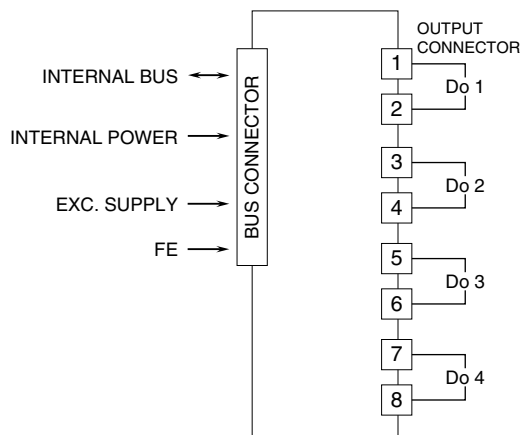

## WIRING INSTRUCTIONS

### ■ Tension clamp terminal block

**Unit side connector:** MSTB2,5/8-GF-5,08 (Phoenix Contact)

**Cable side connector:** FKC2,5/8-STF-5,08 (Phoenix Contact)

**Applicable wire size:** 0.2 – 2.5 mm<sup>2</sup>

**Stripped length:** 10 mm

### Recommended solderless terminal

- AI0,25–10YE 0.25 mm<sup>2</sup> (Phoenix Contact)
- AI0,34–10TQ 0.34 mm<sup>2</sup> (Phoenix Contact)
- AI0,5–10WH 0.5 mm<sup>2</sup> (Phoenix Contact)
- AI0,75–10GY 0.75 mm<sup>2</sup> (Phoenix Contact)
- AI1–10RD 1.0 mm<sup>2</sup> (Phoenix Contact)
- AI1,5–10BK 1.5 mm<sup>2</sup> (Phoenix Contact)
- AI2,5–10BU 1.5 mm<sup>2</sup> (Phoenix Contact)