

High-density Signal Conditioners 10-RACK

DC/FREQUENCY CONVERTER

Functions & Features

- Providing two pulse rate outputs in proportion to DC input signal

Typical Applications

- Totalizing applications in combination with a counter

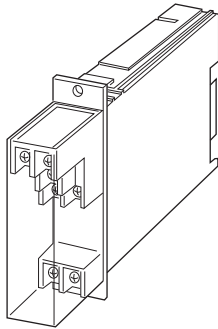

MODEL: 10AP-[1][2][3]-R[4]

ORDERING INFORMATION

- Code number: 10AP-[1][2][3]-R[4]
- Specify a code from below for each of [1] through [4].
(e.g. 10AP-621-R/Q)
- Special input range (For codes Z & 0)
 - Output frequency range (e.g. 0 - 500 Hz)
Frequencies of Output 1 and 2 are the same.
 - Specify the specification for option code /Q
(e.g. /C01)

[1] INPUT

Current

- A:** 4 - 20 mA DC (Input resistance 250 Ω)
- D:** 0 - 20 mA DC (Input resistance 50 Ω)
- G:** 0 - 1 mA DC (Input resistance 1000 Ω)
- H:** 10 - 50 mA DC (Input resistance 100 Ω)
- Z:** Specify current (See INPUT SPECIFICATIONS)
(0 % input must be 0 mA.)

Voltage

- 3:** 0 - 1 V DC (Input resistance 1 MΩ min.)
- 4:** 0 - 10 V DC (Input resistance 1 MΩ min.)
- 5:** 0 - 5 V DC (Input resistance 1 MΩ min.)
- 6:** 1 - 5 V DC (Input resistance 1 MΩ min.)
- 0:** Specify voltage (See INPUT SPECIFICATIONS)
(0 % input must be 0 V.)

[2] OUTPUT 1

- 1: Open collector (max. 1 kHz)
- 2: 5 V pulse (max. 1 kHz)
- 5: Photo MOSFET relay pulse (max. 30 Hz)

[3] OUTPUT 2

- 0: None
- 1: Open collector

POWER INPUT

DC Power

R: 24 V DC

(Operational voltage range 24 V ±10 %, ripple 10 %p-p max.)

[4] OPTIONS

blank: none

/Q: With options (specify the specification)

SPECIFICATIONS OF OPTION: Q

COATING (For the detail, refer to our web site.)

/C01: Silicone coating

/C02: Polyurethane coating

/C03: Rubber coating

GENERAL SPECIFICATIONS

Construction: Rack-mounted; terminal access via screw terminals at the front and via card-edge connector at the rear; terminal cover provided

Connection

Input: M3.5 screw terminals (torque 0.8 N·m)

Output: Card-edge connector and M3.5 screw terminals (torque 0.8 N·m)

Power input: Supplied from card-edge connector

Screw terminal: Nickel-plated steel

Housing material: Flame-resistant resin (black)

Isolation: Input to output 1 to output 2 to power

Overrange output: Approx. 0 to 120 %

Zero adjustment: 0 - 5 % (front)

Span adjustment: 95 to 105 % (front)

INPUT SPECIFICATIONS

■ **DC Current:** Input resistor incorporated
Specify input resistance value for code Z.
($R \leq 2 W \div [F.S. Current]^2$)

■ **DC Voltage:** 0 - 300V DC

Minimum span: 1V

Input resistance: 1 MΩ min.

OUTPUT SPECIFICATIONS

■ **Open Collector:** 30 V DC @ 100 mA (resistive load)

Frequency range: 0 - 10 pulses/hour through 1 kHz

Saturation voltage: 0.6 V DC

When output 1 is photo MOSFET relay pulse, a timer for output 2 is provided, which limits ON time within 75 ±25msec.

■ **5 V Pulse**

Frequency range: 0 - 10 pulses/hour through 1 kHz

Hi level: 3.0 - 5.5 V

Lo level: ≤ 0.5 V

Load resistance: 250 Ω min.

■ **Photo MOSFET Relay Pulse**

Frequency range: 0 - 10 pulses/hour through 30 Hz

Timer: Limits ON time within 75 ±25 msec.

Rating: 132 V AC @ 200 mA (cos φ = 1)

30 V DC @ 200 mA (resistive load)

ON resistance: ≤ 2 Ω

INSTALLATION

Current consumption: Approx. 60 mA

Operating temperature: -5 to +55°C (23 to 131°F)

Operating humidity: 30 to 90 %RH (non-condensing)

Mounting: Standard Rack 10BXx

Weight: 200 g (0.44 lb)

PERFORMANCE in percentage of span

Accuracy: ±0.1 %

Temp. coefficient: ±0.015 %/°C (±0.008 %/°F)

Response time: Approx. 3 sec. (0 - 90 %)

Line voltage effect: ±0.1 % over voltage range

Insulation resistance: ≥ 100 MΩ with 500 V DC

Dielectric strength: 500 V AC @ 1 minute

(input to output 1 to output 2 to power)

1500 V AC @ 1 minute (input or output or power to ground)

OUTPUT PULSE WIDTH

■ **Frequency less than 500 Hz at 100% input**

→ Duty ratio 20% (See the figure below)

• **Open Collector**

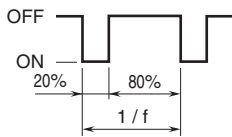

• **Voltage Pulse**

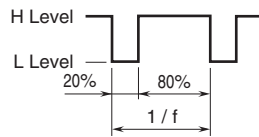

■ **Frequency greater than 500 Hz at 100% input**

→ See the figure and equation below.

• **Open Collector**

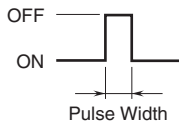

• **Voltage Pulse**

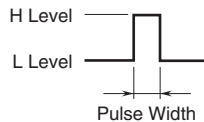

$$\text{Pulse Width [millisec.]} = \frac{1}{2.09 \times 100\% \text{ Frequency [kHz]}}$$

■ **When OUTPUT 1 is Photo MOSFET Relay Pulse**

→ See the figure below. ON pulse width is limited within 75 ±25 msec. when the output frequency gets low (below 2 to 4 Hz).

• **OUTPUT 2's Open Collector and Photo MOSFET Relay Pulse**

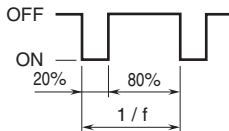

EXTERNAL DIMENSIONS & TERMINAL ASSIGNMENTS unit: mm [inch]

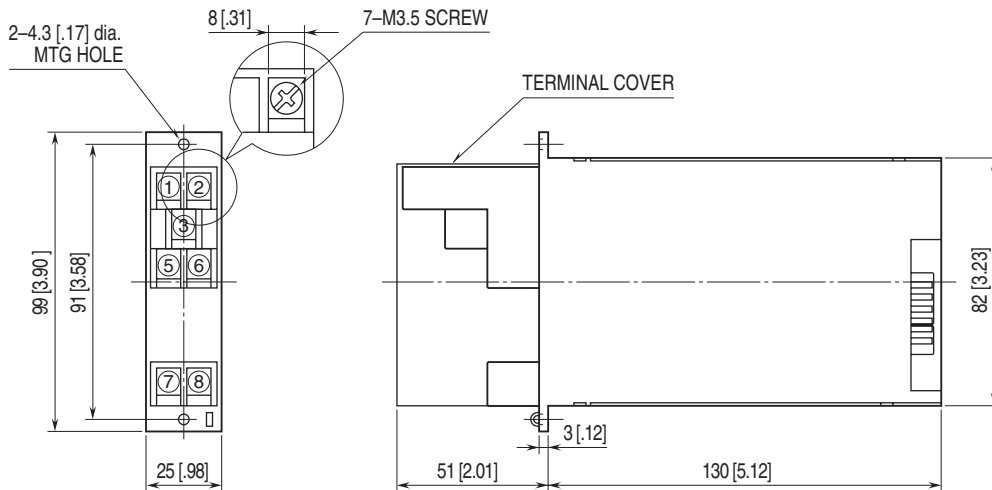

SCHEMATIC CIRCUITRY & CONNECTION DIAGRAM

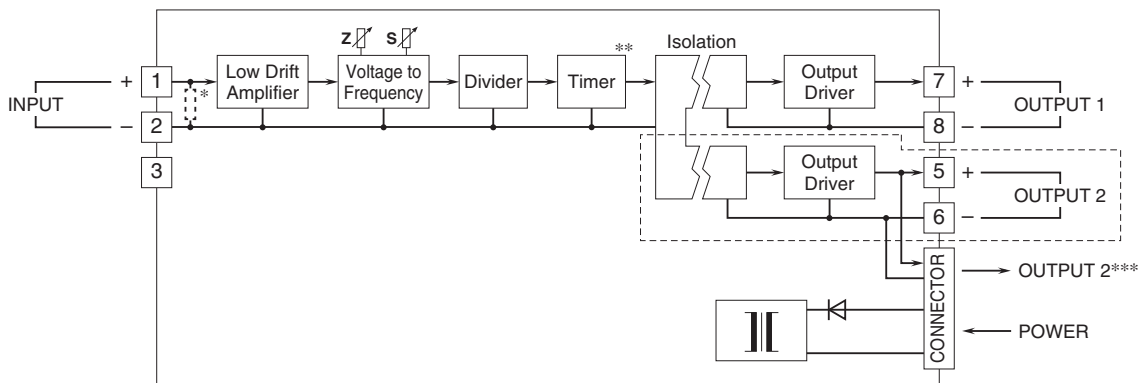

* Input shunt resistor incorporated for current input.
 ** Photo MOSFET relay pulse only.
 *** For 1 output channel type, OUTPUT 1 is also connected to the card-edge connector inside.
 Note: The section enclosed by broken line is only for 2nd output channel.

Output Connection Examples

■ Open Collector

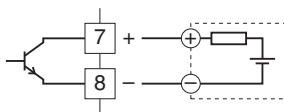

■ Voltage Pulse

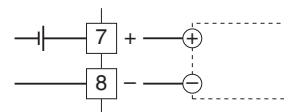

■ Photo MOSFET Relay Pulse

• AC Powered

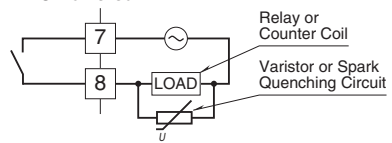

• DC Powered

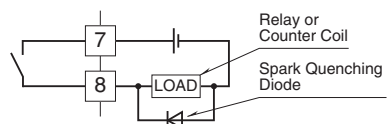

Specifications are subject to change without notice.