

## Dual Channel Input/Output Isolators 15-RACK

### SIGNAL CONVERTER

(high speed response)

#### Functions & Features

- Converting a DC input into a standard process signal
- 2 channels available; accomplishing economical and space-saving multi-input processing

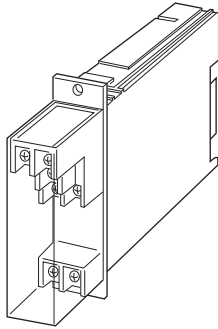

### MODEL: 15VF-[1]6-R[2]

#### ORDERING INFORMATION

- Code number: 15VF-[1]6-R[2]

Specify a code from below for each of [1] and [2].

- (e.g. 15VF-46-R/Q)
- Special input range (For code 0)
- Specify the specification for option code /Q (e.g. /C01)

#### [1] INPUT

Current

**A:** 4 - 20 mA DC (Input resistance 250 Ω)

**D:** 0 - 20 mA DC (Input resistance 50 Ω)

**G:** 0 - 1 mA DC (Input resistance 1000 Ω)

**H:** 10 - 50 mA DC (Input resistance 100 Ω)

Voltage

**3:** 0 - 1 V DC (Input resistance 1 MΩ min.)

**4:** 0 - 10 V DC (Input resistance 1 MΩ min.)

**5:** 0 - 5 V DC (Input resistance 1 MΩ min.)

**6:** 1 - 5 V DC (Input resistance 1 MΩ min.)

**0:** Specify voltage (See INPUT SPECIFICATIONS)

#### OUTPUT

Voltage

**6:** 1 - 5 V DC (Load resistance 5000 Ω min.)

#### POWER INPUT

DC Power

**R:** 24 V DC

(Operational voltage range 24 V ±10 %, ripple 10 %p-p max.)

#### [2] OPTIONS

**blank:** none

**/Q:** With options (specify the specification)

#### SPECIFICATIONS OF OPTION: Q

**COATING** (For the detail, refer to our web site.)

**/C01:** Silicone coating

**/C02:** Polyurethane coating

**/C03:** Rubber coating

#### RELATED PRODUCTS

- Extender card (model:10EC)

Necessary to adjust span.

#### GENERAL SPECIFICATIONS

**Construction:** Rack-mounted; terminal access via screw terminals at the front and via card-edge connector at the rear; terminal cover provided

#### Connection

**Input:** M3.5 screw terminals (torque 0.8 N·m)

**Output:** Card-edge connector and M3.5 screw terminals (torque 0.8 N·m)

**Power input:** Supplied from card-edge connector

**Screw terminal:** Nickel-plated steel

**Housing material:** Flame-resistant resin (black)

**Isolation:** Input to output or power; ch.1 input to ch.2 input

**Overrange output:** Approx. -10 to +120 %

**Zero adjustment:** -5 to +5 % (front)

**Span adjustment:** 95 to 105 % (top)

#### INPUT SPECIFICATIONS

■ **DC Current:** Input resistor incorporated

• **DC Voltage:** 0 - 30 V DC

**Minimum span:** 1 V

**Offset:** Max. 1.5 times span

**Input resistance:** ≥ 1 MΩ

#### OUTPUT SPECIFICATIONS

With the input voltage code 3, 4, 5, 6 and current, the output goes below 0 % when the input is open.

## INSTALLATION

**Power consumption:** Approx. 20 mA  
**Operating temperature:** -5 to +55°C (23 to 131°F)  
**Operating humidity:** 30 to 90 %RH (non-condensing)  
**Mounting:** Standard Rack 15BX  
**Weight:** 180 g (0.40 lb)

## PERFORMANCE in percentage of span

**Accuracy:**  $\pm 0.1\%$   
**Temp. coefficient:**  $\pm 0.015\%/^{\circ}\text{C}$  ( $\pm 0.008\%/^{\circ}\text{F}$ )  
**Response time:**  $\leq 200$  microseconds (0 - 90 %)  
**Line voltage effect:**  $\pm 0.1\%$  over voltage range  
**Insulation resistance:**  $\geq 100\ \text{M}\Omega$  with 500 V DC  
**Dielectric strength:** 500 V AC @ 1 minute  
 (input to output or power)  
 500 V AC @ 1 minute (ch.1 to ch.2 input)  
 500 V AC @ 1 minute (output to ground)

## EXTERNAL DIMENSIONS & TERMINAL ASSIGNMENTS unit: mm [inch]

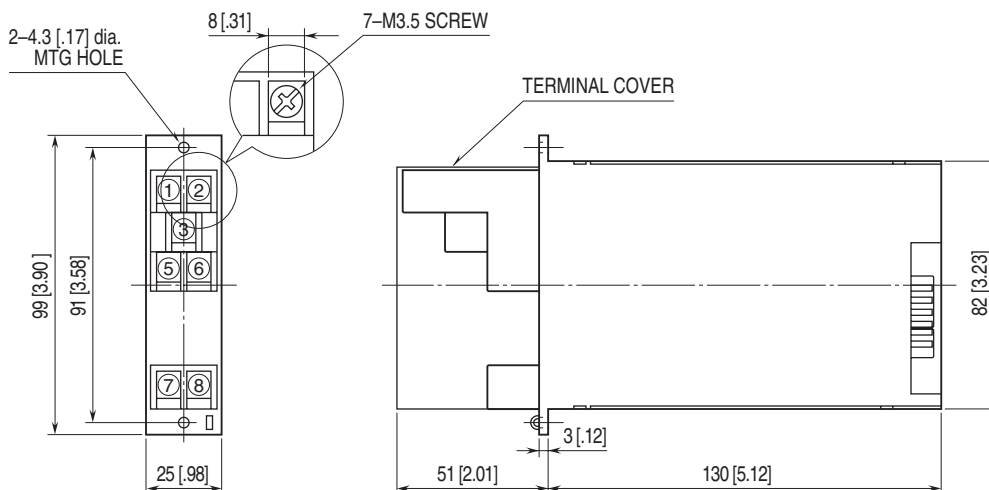

## SCHEMATIC CIRCUITRY & CONNECTION DIAGRAM

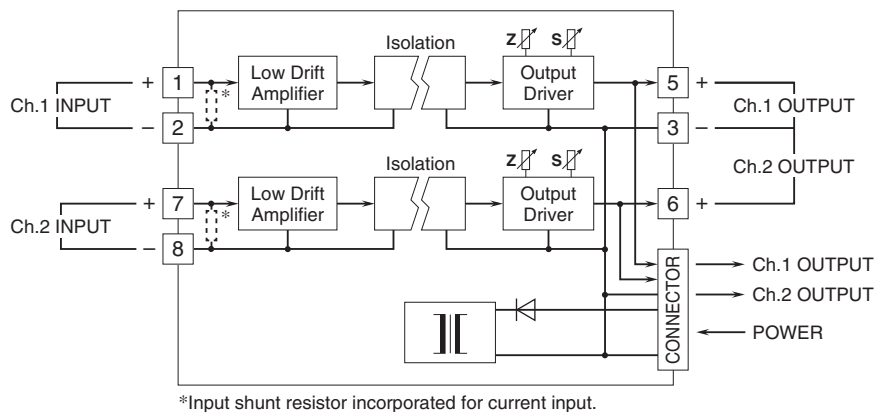



Specifications are subject to change without notice.