

Rack-mounted DCS Signal Conditioners 18-RACK

CURRENT LOOP SUPPLY

(applicable to HART signal, opencircuit detection selectable)

Functions & Features

- Powers a 4 - 20 mA DC current loop
- Isolates and relays HART signals
- Shortcircuit protection
- Opencircuit detection selectable

Typical Applications

- 2-wire HART transmitters

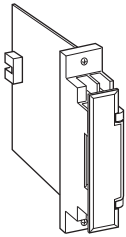

MODEL: 18DYH2-A6A-R[1]

ORDERING INFORMATION

- Code number: 18DYH2-A6A-R[1]

Specify a code from below for [1].

(e.g. 18DYH2-A6A-R/B)

INPUT

Current

A: 4 - 20 mA DC (Input resistance approx. 250Ω)

OUTPUT 1

Voltage

6: 1 - 5 V DC (Load resistance 2000 Ω min.)

OUTPUT 2

Current

A: 4 - 20 mA DC (Load resistance 600 Ω max.)

250 Ω ±10% for HART communication

POWER INPUT

DC Power

R: 24 V DC

(Operational voltage range 24 V ±10 %, ripple 10 %p-p max.)

[1] OPTIONS

Opencircuit detection

blank: none

/B: Opencircuit detector

GENERAL SPECIFICATIONS

Construction: Rack-mounted; terminal access via screw terminals on the front and connector on the rear; terminal cover provided

Connection

Input: M3.5 screw terminals (torque 0.8 N·m)

Output 1: Connector

Output 2: M3.5 screw terminals (torque 0.8 N·m) and connector

Power input: Supplied from connector

Screw terminal: Nickel-plated steel

Isolation: Input to output 1 to output 2 to power

Overrange output: Approx. -10 to +110 %

Zero adjustment: -5 to +5 % (front)

Span adjustment: 95 to 105 % (front)

Opencircuit detection: Input current 0 mA when the output loop is open.

Photo MOSFET Relay ON Resistance; 3 Ω max.

SUPPLY OUTPUT

(across the terminals 1 - 2)

Output voltage: 24 - 28 V DC with no load

18 V DC min. at 20 mA

Current rating: ≤ 22 mA DC

- Shortcircuit Protection

Current limited: 30 mA max.

Protected time duration: No limit

INPUT SPECIFICATIONS

■ **DC Current:** Input resistor incorporated

Input current: ≥ 0 mA

OUTPUT SPECIFICATIONS

The output goes below 0 % when the input is open.

HART COMMUNICATION

Transmission gain: Approx. -3 dB (within 1 - 3 kHz) measured with 250 Ω at output

Loop impedance: 250 Ω ±10 %

Communication directions: Bidirectional

INSTALLATION

Current consumption: Approx. 120 mA

Operating temperature: -5 to +55°C (23 to 131°F)

Operating humidity: 30 to 90 %RH (non-condensing)

Mounting: Standard Rack 18BXx or 18KBXx

Weight: 110 g (0.24 lb)

PERFORMANCE in percentage of span

Accuracy: $\pm 0.1\%$

Temp. coefficient: $\pm 0.015\%/^{\circ}\text{C}$ ($\pm 0.008\%/^{\circ}\text{F}$)

Response time: ≤ 0.5 sec. (0 - 90 %)

Line voltage effect

Supply output: $\pm 3\%$ over voltage range

Output signal: $\pm 0.1\%$ over voltage range

Insulation resistance: $\geq 100\ \text{M}\Omega$ with 500 V DC

Dielectric strength: 1500 V AC @ 1 minute

(input to output 1 or output 2 or power)

500 V AC @ 1 minute

(output 1 to output 2 to power)

1500 V AC @ 1 minute

(input or output or power to ground)

EXTERNAL DIMENSIONS unit: mm [inch]

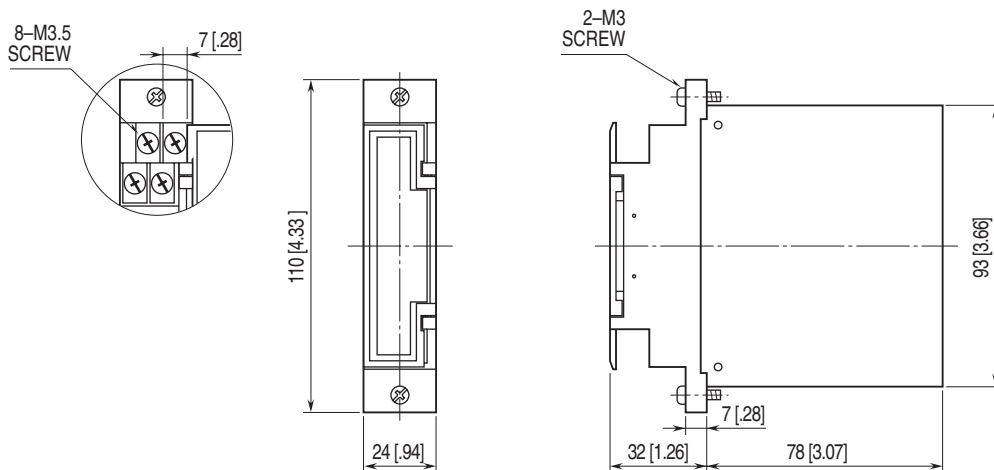

TERMINAL ASSIGNMENTS

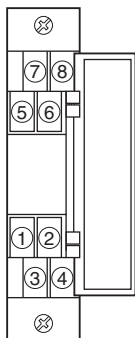

SCHEMATIC CIRCUITRY & CONNECTION DIAGRAM

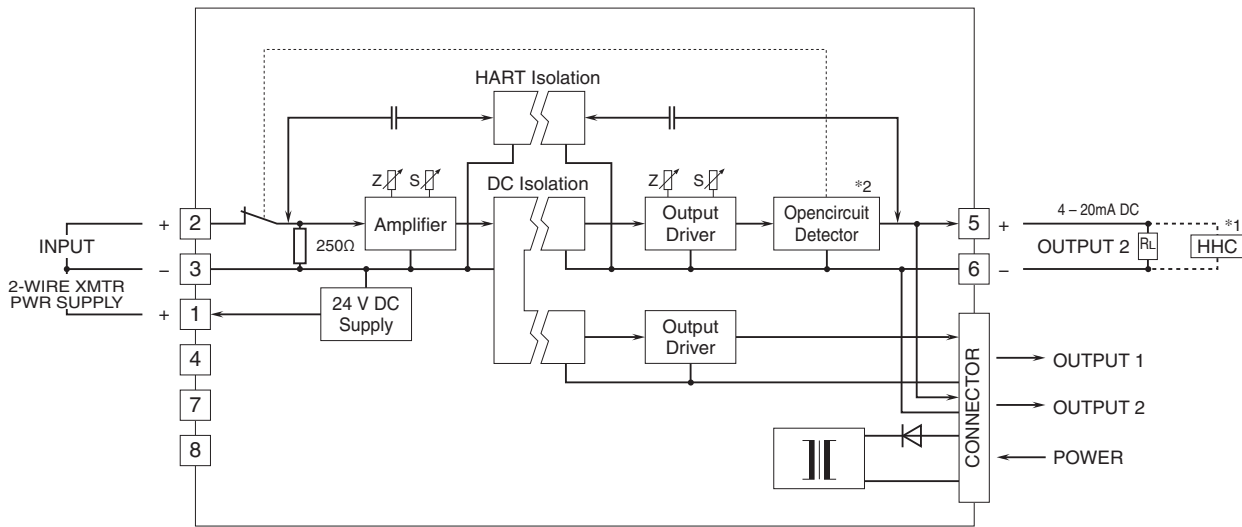

For OUTPUT 2, use either of terminals on the front or connector on the rear.

*1. Hand-held communicator

*2. Included with option /B

■ When used as DC Supply

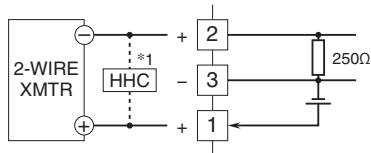

■ When used as Isolator

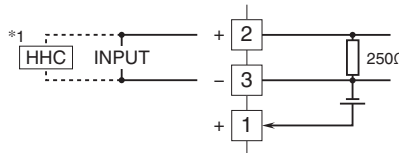

Specifications are subject to change without notice.